

Housing - HC-D 25-AMLD - 1672754

Please be informed that the data shown in this PDF Document is generated from our Online Catalog. Please find the complete data in the user's documentation. Our General Terms of Use for Downloads are valid (<http://phoenixcontact.com/download>)



HEAVYCON panel mounting base D25, with single locking latch, height 26 mm, with cover



Key Commercial Data

Packing unit	10 pc
GTIN	 4 017918 152536
GTIN	4017918152536

Technical data

Dimensions

Height	26 mm
Width	30.5 mm
Length	96 mm
Length of the assembly cutout	74 mm
Width of the assembly cutout	24 mm

Ambient conditions

Degree of protection of housing (IP)	IP65 (When plugged in)
	IP54 (with closed protective cover)
Ambient temperature (operation)	-40 °C ... 125 °C

General

Note	For contact inserts HC-D25, A16
Size	D25
Housing type	Panel mounting base
Locking type	with single locking latch
Screw connection	none
Protective cover	yes
Housing material	Aluminum die-cast

Housing - HC-D 25-AMLD - 1672754

Technical data

General

Housing surface material	Powder-coated, gray
Material lock	Steel, galvanized
Material, protective cover	PA
Assembly instructions	The flat gasket is supplied closed. The required opening is not created until the assembly stage.

Environmental Product Compliance

China RoHS	Environmentally friendly use period: unlimited = EFUP-e
	No hazardous substances above threshold values

Drawings

Dimensional drawing

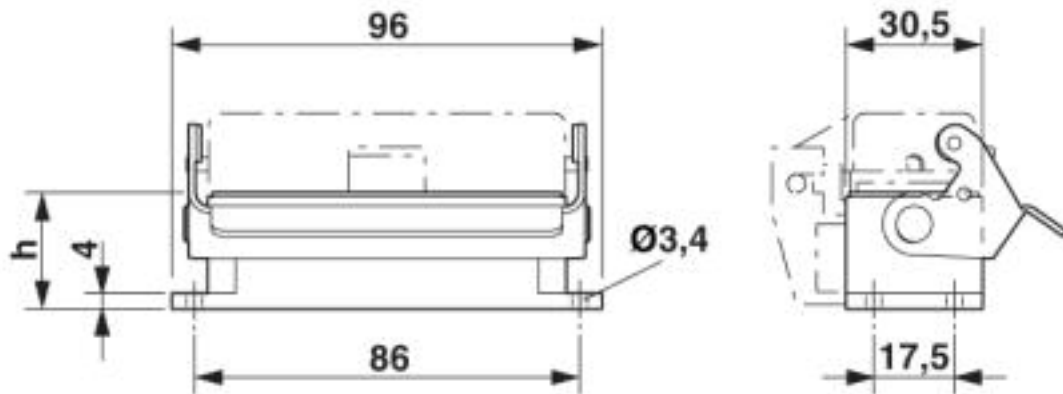

Dimensional drawing

Housing - HC-D 25-AMLD - 1672754

Dimensional drawing

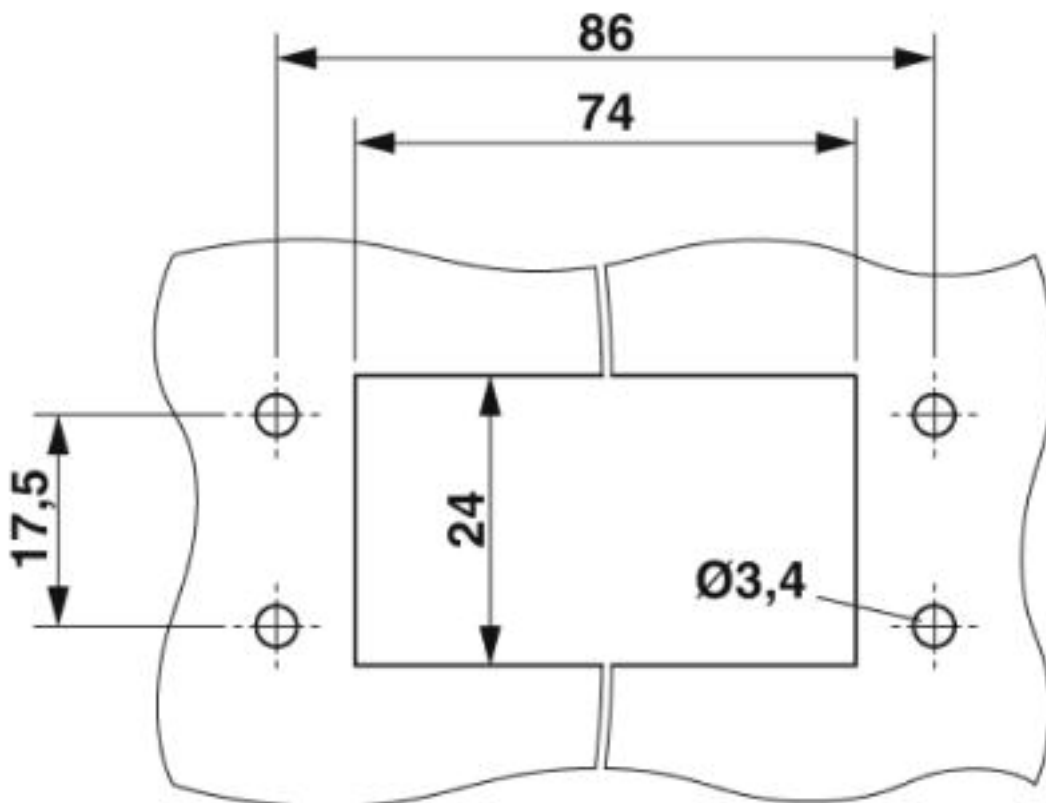

Mounting cutout

Classifications

eCl@ss

eCl@ss 4.0	27140800
eCl@ss 4.1	27140800
eCl@ss 5.0	27143400
eCl@ss 5.1	27261200
eCl@ss 6.0	27261200
eCl@ss 7.0	27440202
eCl@ss 8.0	27440202
eCl@ss 9.0	27440202

ETIM

ETIM 2.0	EC000437
ETIM 3.0	EC000437
ETIM 4.0	EC000437
ETIM 5.0	EC000437
ETIM 6.0	EC000437

Housing - HC-D 25-AMLD - 1672754

Classifications

ETIM

ETIM 7.0	EC000437
----------	----------

UNSPSC

UNSPSC 6.01	31261502
UNSPSC 7.0901	31261502
UNSPSC 11	31261502
UNSPSC 12.01	31261502
UNSPSC 13.2	31261501
UNSPSC 19.0	31261501

Phoenix Contact 2020 © - all rights reserved
<http://www.phoenixcontact.com>

PHOENIX CONTACT GmbH & Co. KG
Flachsmarktstr. 8
32825 Blomberg
Germany
Tel. +49 5235 300
Fax +49 5235 3 41200
<http://www.phoenixcontact.com>