

PART NUMBER	REVISION	DESCRIPTION	FEED TYPE
2151119-1	E	FINE CRIMP HEIGHT ADJUST	MECHANICAL
2151119-2	E	FINE CRIMP HEIGHT ADJUST	PNEUMATIC
7-2151119-1	E	MECHANICAL AND CRIMP TOOLING KIT	MECHANICAL
7-2151119-2	E	PNEUMATIC AND CRIMP TOOLING KIT	PNEUMATIC
7-2151119-7	A	CRIMP TOOLING KIT	-

ATLANTIC VERSION TERMINATOR INTERFACE ADAPTER



APPLICATOR DATA		
CRIMP	SIZE	TYPE
WIRE	2.54 mm [.100]	F
INSUL	2.79 mm [.110]	F

APPLICATOR INSTRUCTIONS  
408-35042

TERMINAL DATA: TE TERMINAL		TE CRIMP SPECIFICATION	
TERMINAL NAME: "2L" SIZE DYNAMIC D-3 REC. & TAB			
WIRE STRIP LENGTH	INSULATION DIAMETER RANGE		
4.30-5.30 mm [.169-.209 IN]	Ø2.20-2.80 mm [.087-.110 IN]		
TERMINAL APPLICATION SPECIFICATION	(A)114-5148 (B)114-78024 (C)114-78030		
TERMINALS APPLIED			
TE TERMINAL	TE TERMINAL	TE TERMINAL	TE TERMINAL
(A) 917484-2	(A) 1-917484-2	(A) 917484-3	(A) 1-917484-3
(A) 1-917484-5	(A) 917485-2	(A) 917485-3	(A) 917485-5
(B) 2316815-4	(C) 2298107-4		

WIRE SIZE	CRIMP HEIGHT mm [INCH]	CRIMP HEIGHT REFERENCE SETTING
14 AWG OR 2.20mm2	1.68+/-0.05 [.066+/-0.002]	5.3
16 AWG OR 1.25mm2	1.45+/-0.05 [.057+/-0.002]	7.7

- 1. RECOMMENDED SPARE PARTS
- 2. REFER TO SUPPLIED INSTRUCTION SHEET FOR CLEANING, LUBRICATION AND STORAGE OF APPLICATOR.
- 3. APPLY PART NUMBER 2-23419-6 LOCTITE TO THREADS OF ITEM 242.
- 4. CRIMP HEIGHT REFERENCE SETTING WAS THE SETTING USED WHEN THE APPLICATOR WAS QUALIFIED AT THE FACTORY. ADJUSTMENT MAY BE NECESSARY WHEN RUNNING APPLICATOR IN THE FIELD.
- 5. TERMINAL LUBRICANT IS RECOMMENDED.
- 6. UNLESS SPECIFIED OTHERWISE TORQUE VALUES SHALL BE USED PER DOCUMENT, 101-35000.

**\*WARNING**  
ON INSTALLATION, SET WIRE DISC TO CRIMP HEIGHT REFERENCE SETTING FOR LARGEST WIRE SIZE. CRIMP HEIGHT REFERENCE SETTINGS GREATER THAN THE VALUE SHOWN MAY CAUSE DAMAGE TO THE CRIMP TOOLING. REFER TO THE INSTRUCTION SHEET FOR PROPER SETUP AND ADJUSTMENTS.

LOC	DIST	REVISIONS					
A	66	P	LTN	DESCRIPTION	DATE	OWN	APVD
		B		ECR-17-012459	25AUG2017	KH	CT
		C		ECR-18-006851	03MAY2018	TB	JDG
		D		ECR-18-011849	25JUL2018	FZ	KZ
		E		ECR-19-005446	04APR2019	FL	GB

-	1	-	1	-	2119640-1	PUSH ROD, AIR FEED	250
-	1	-	1	-	2079988-1	BUSHING, LCH5-12, MISUMI	249
-	1	-	1	-	2119641-1	FEED CAM, AIR FEED	248
-	1	1	1	1	2119082-9	CAM, SNAIL, INSULATION ADJUSTMENT	244
-	1	1	1	1	2079764-1	WASHER, WAVE SPRING, CREST-TO-CREST	243
-	1	1	1	1	2119083-1	RETAINER, INSULATION DIAL	242
-	1	1	1	1	7-18023-7	SCR, SKT HD CAP M3 X 4.0	241
-	-	1	-	1	2119580-1	MECHANICAL FEED ASSEMBLY	239
-	1	-	1	-	2063440-1	AIR FEED MODULE	238
-	2	-	2	-	21045-3	RING, RETAIN, EXTERN, 3/16 CRESCENT	172
-	REF	REF	REF	REF	994970-2	COUNTER, MAGNETIC	164
-	1	-	1	-	240638-1	SPRING, FEED FINGER	163
-	1	-	1	-	3-23627-7	PIN, RETAIN, GRVD, 3/16 X .854	137
-	1	-	1	-	2119799-1	HOLDER, FEED FINGER, AF	136
-	1	1	1	1	1-18028-2	WASHER, FLAT, REG M4	119
-	1	1	1	1	2119955-1	ASSY, LUBRICATOR, SIDE FEED	113
-	1	1	1	1	2844908-1	SCREW, LOCKING	99
-	1	1	1	1	2844907-1	POST, LOCKING	98
-	1	1	1	1	455888-4	SPACER, CRIMPER	82
-	1	1	1	1	5-547505-2	SPRING, COMPRESSION	77
-	1	1	1	1	854769-4	HOLDER, INS	74
-	1	1	1	1	1803607-1	DOCUMENTATION PACKAGE	71
-	1	1	1	1	2119740-1	TAG, IDENTIFICATION	67
-	2	2	2	2	2168078-1	SCREW, DRIVE, RH, RoHS, 2 x .188	66
-	1	1	1	1	2168083-2	SCR, SKT HD CAP, RoHS, M4 X 8.0	60
-	1	1	1	1	5-18022-5	SCR, HEX HD CAP, M4 X 6.0	59
-	1	1	1	1	21028-2	PIN, SLOTTED SPRING .062 X .250	58
-	1	1	1	1	1338685-1	PAWL, FEED	56
-	4	4	4	4	2168083-3	SCR, SKT HD CAP, RoHS, M4 X 12.0	54
-	2	2	2	2	1-2168083-0	SCR, SKT HD CAP, RoHS, M4 X 10	53
-	1	1	1	1	5018030-1	NUT, HEX, REG, RoHS, M3	52
-	1	1	1	1	811242-5	BUMPER, HOLD DOWN	51
-	1	1	1	1	690753-2	SPACER, TONKER	50
-	1	2	1	2	18023-9	SCR, SKT HD CAP M4 X 6.0	49
-	-	1	-	1	2119652-1	FEED CAM, PRE FEED	48
-	-	1	-	1	2119653-1	FEED CAM, POST FEED	47
-	1	1	1	1	1803583-9	APPLICATOR BASIC ASSEMBLY, SF	46
-	1	1	1	1	1803515-1	RAM ASSEMBLY, SF ATLANTIC	44
-	1	1	1	1	1803602-1	SCR, BHSC, RoHS (M8 X 25)	41
-	1	1	1	1	1752356-3	SUPPORT, TERMINAL	34
-	2	2	2	2	2079383-5	SCR, BHSC, RoHS (M4 X 20)	33
-	2	2	2	2	2-2844962-8	SPACER, CYLINDRICAL, STRIP GUIDE	30
-	1	1	1	1	2844992-1	ASSEMBLY, STRIP GUIDE	29
-	1	1	1	1	1-455888-0	SPACER, CRIMPER	28
-	1	1	1	1	1320928-6	STRIP GUIDE	24
-	1	1	1	1	2168083-2	SCR, SKT HD CAP, RoHS, M4 X 8.0	21
-	1	1	1	1	1-18028-2	WASHER, FLAT, REG M4	20
-	1	1	1	1	2119533-3	STRIPPER, SIDE FEED	19
-	1	1	1	1	2119806-1	INSERT, SHEAR	13
-	1	1	1	1	3-22280-3	SPRING, COMPRESSION	12
-	1	1	1	1	1-356885-4	STOP, SHEAR	11
-	1	1	1	1	2119805-1	SHEAR HOLDER, FRONT	10
-	1	1	1	1	1803095-1	FLOATING SHEAR, FRONT	9
-	1	2	1	1	2-1333206-5	ANVIL, COMBINATION .100	8
-	1	1	1	1	2119780-9	DEPRESSOR, SHEAR	5
-	1	1	1	1	2-238011-2	BLOCK, CRIMPER SPACER	4
-	1	2	2	1	2-2119582-1	CRIMPER, INSULATION F PREMIUM	3
-	1	1	1	1	455888-6	SPACER, CRIMPER	2
-	1	2	2	1	1-456407-4	CRIMPER, WIRE PREMIUM	1

ATLANTIC VERSION  
Shown on sheets 1 of 4 & 2 of 4  
(Pacific version shown on sheets 3 of 4 & 4 of 4)

DIMENSIONS:		TOLERANCES UNLESS OTHERWISE SPECIFIED:		MATERIAL:		FINISH:	
mm	0 PLC ±	1 PLC ±	2 PLC ±	3 PLC ±	4 PLC ±	ANGLES	

OWN	S. ZOU	08JUN2011	TE Connectivity Harrisburg, PA 17105-3608
CHK	G. BAILEY	08JUN2011	
APVD	S. XI	08JUN2011	NAME
PRODUCT SPEC			Ocean Side Feed
APPLICATION SPEC			Applicator
SIZE	CAGE CODE	DRAWING NO	RESTRICTED TO
A1	00779	2151119	
Customer Accessible Production Drawing			SCALE 1:2 SHEET 1 OF 4 REV E

LOC	DIST	REV	DATE	BY	APPV
A	66				

# FEED TYPE MECHANICAL



# PNEUMATIC

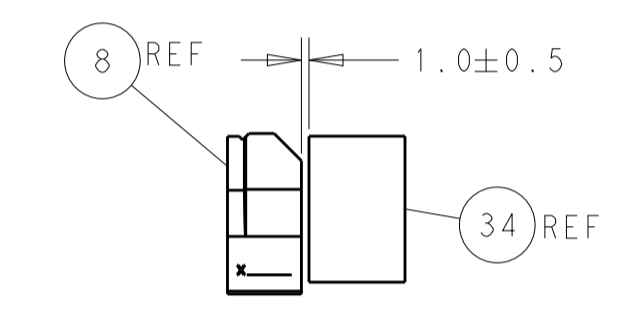
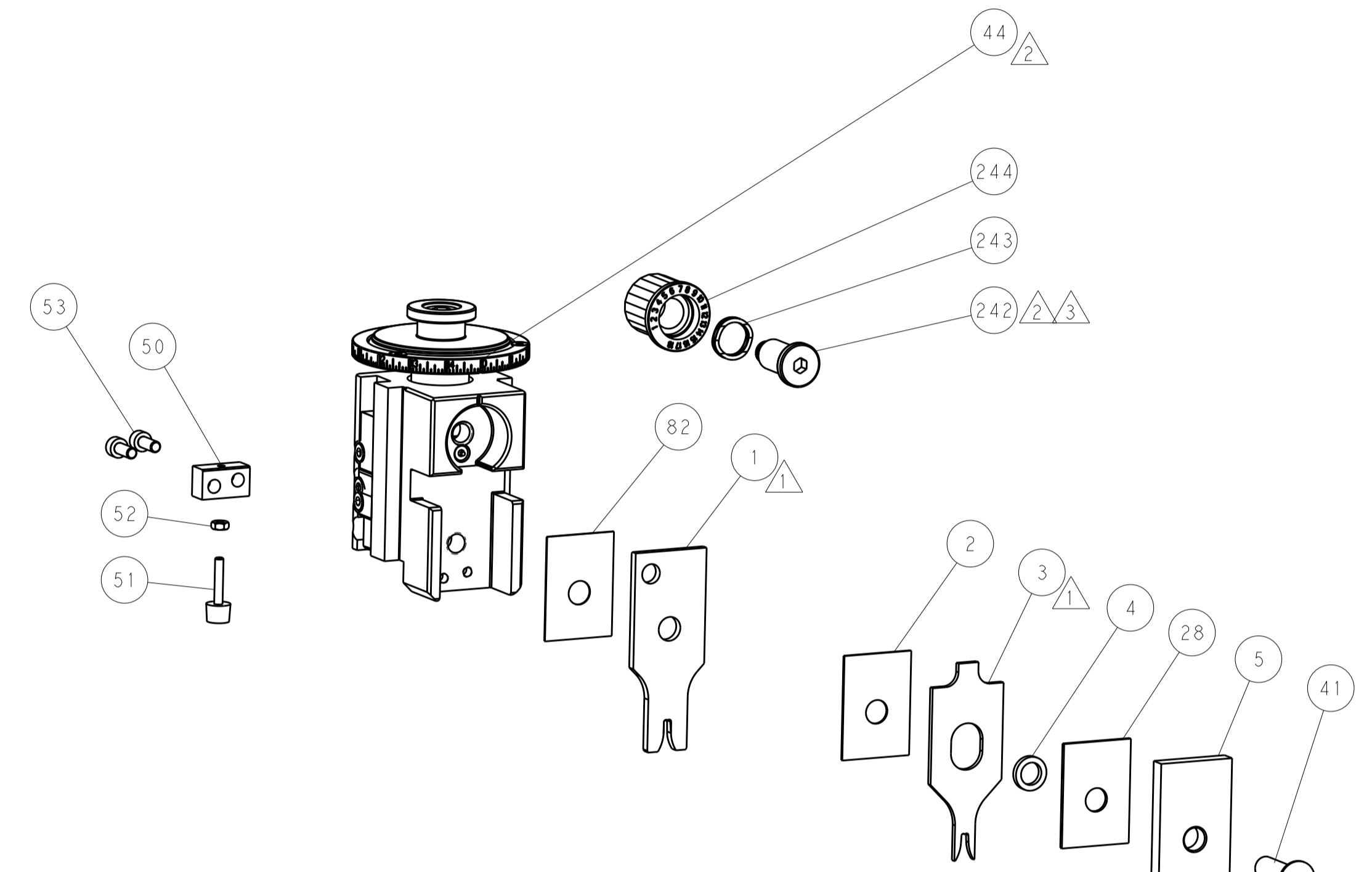
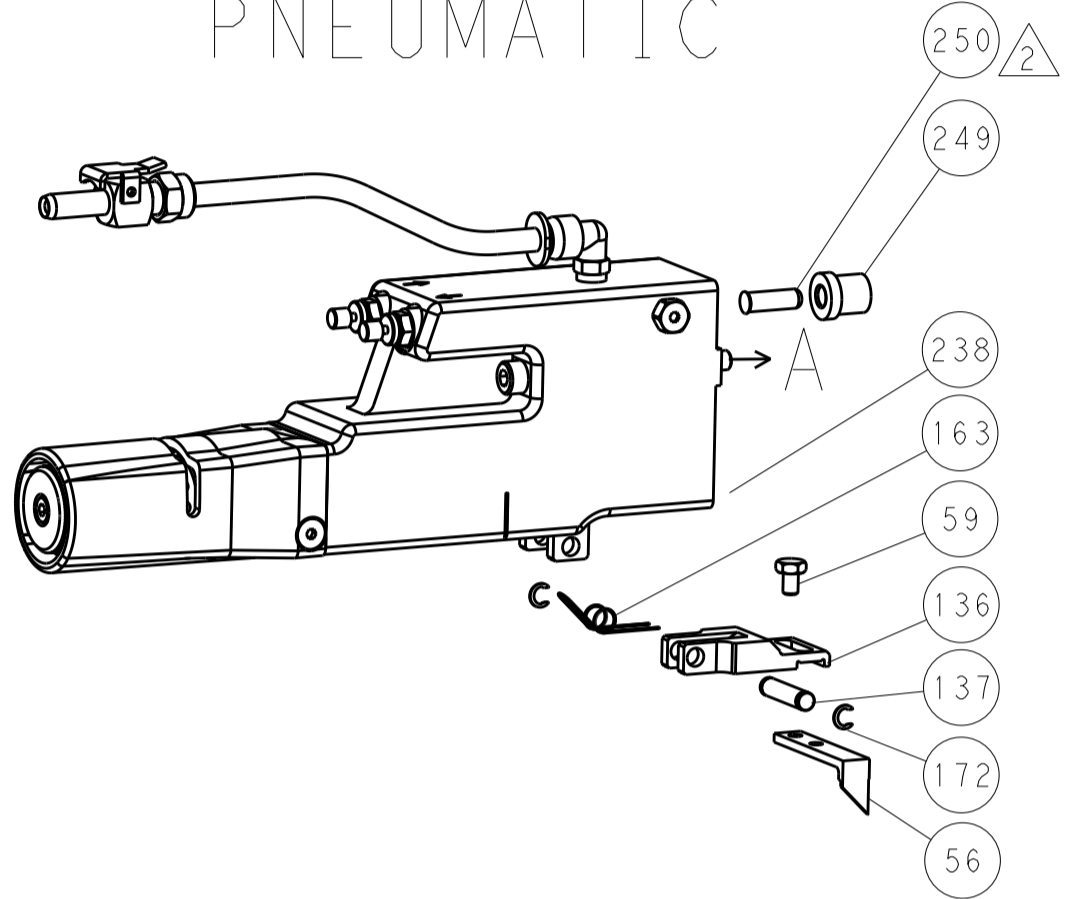

TERMINAL SUPPORT LOCATION

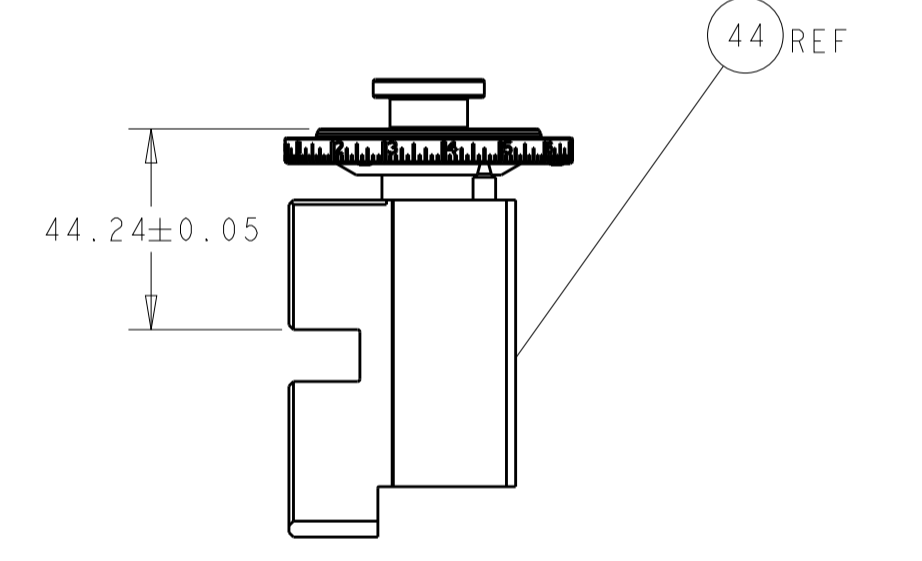

RAM SET-UP

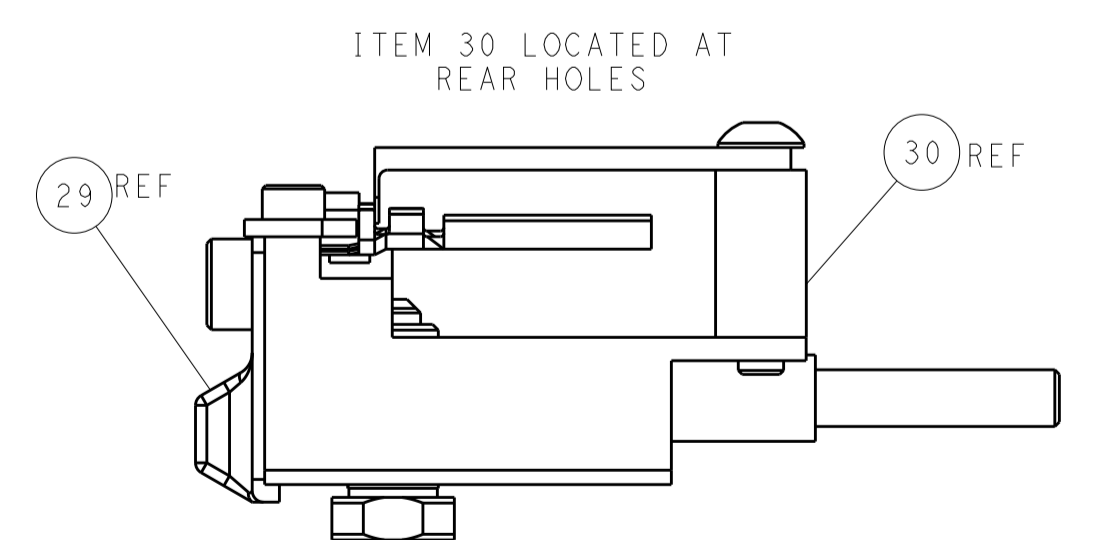
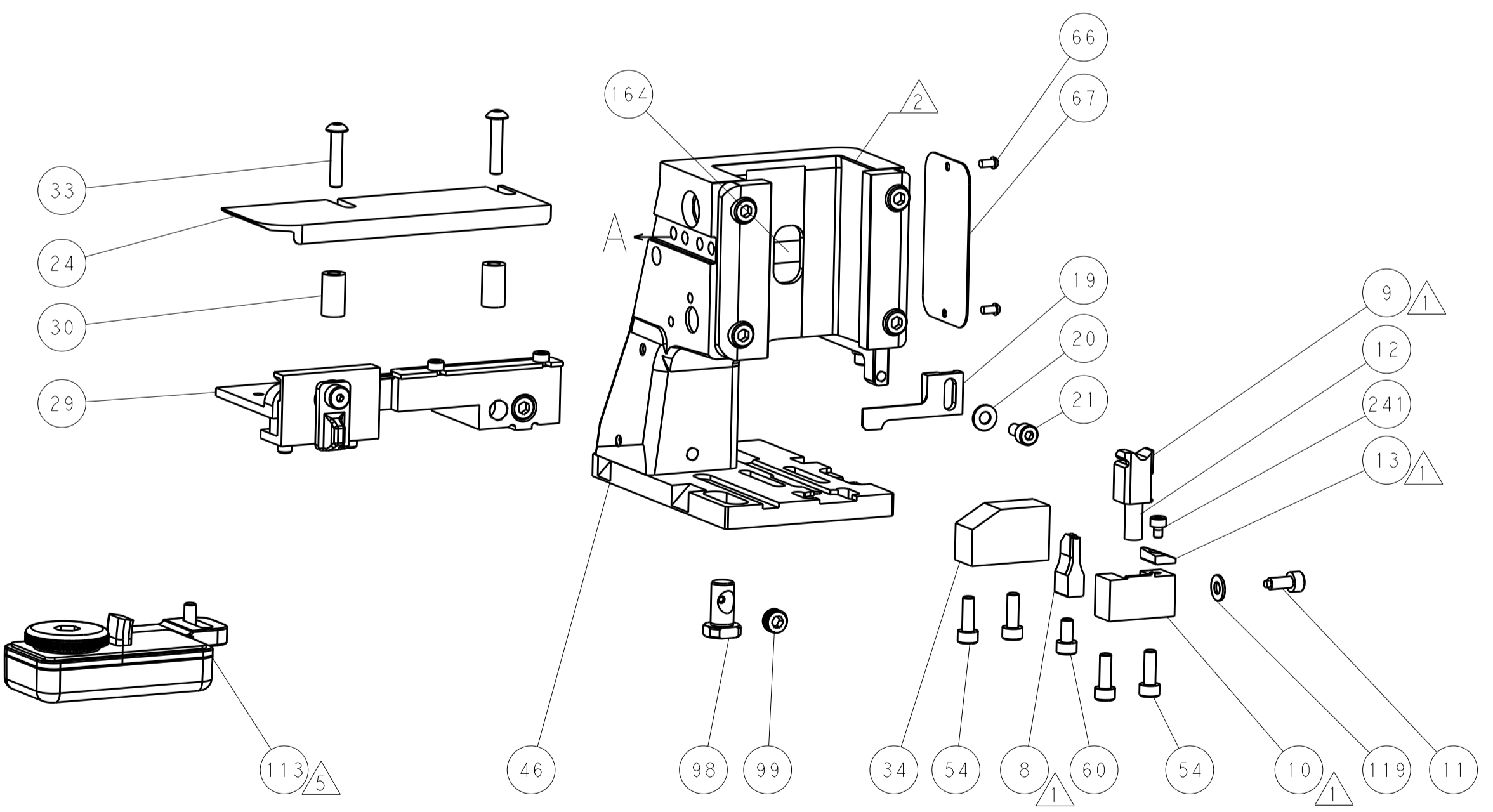

FEED TRACK POSITION GUIDE BY INSULATION BARREL

# CAM POSITIONS



**ATLANTIC VERSION**  
 Shown on sheets 1 of 4 & 2 of 4  
 (Pacific version shown on sheets 3 of 4 & 4 of 4)

DIMENSIONS:		TOLERANCES UNLESS OTHERWISE SPECIFIED:		DWN S. ZOU 08JUN2011		TE Connectivity	
mm	0 PLC	±		CHK G. BAILEY 08JUN2011	NAME	Ocean Side Feed Applicator	
	1 PLC	±		APPV S. XI 08JUN2011	PRODUCT SPEC	SIZE	CAGE CODE DRAWING NO
	2 PLC	±			APPLICATION SPEC	A1	00779 ©=2151119
	3 PLC	±			WEIGHT	Customer Accessible Production Drawing	SCALE 1:2 SHEET 2 OF 4 REV E
	4 PLC	±			FINISH		
MATERIAL							

PART NUMBER	REVISION	DESCRIPTION	FEED TYPE
2-2151119-1	E	FINE CRIMP HEIGHT ADJUST	MECHANICAL
2-2151119-2	E	FINE CRIMP HEIGHT ADJUST	PNEUMATIC
7-2151119-7	A	CRIMP TOOLING KIT	-

PACIFIC VERSION TERMINATOR  
 INTERFACE ADAPTER



APPLICATOR DATA		
CRIMP	SIZE	TYPE
WIRE	2.54 mm [.100]	F
INSUL	2.79 mm [.110]	F

APPLICATOR INSTRUCTIONS  
 408-35042

TERMINAL DATA: TE TERMINAL		TE CRIMP SPECIFICATION	
TERMINAL NAME: "2L" SIZE DYNAMIC D-3 REC. & TAB			
WIRE STRIP LENGTH		INSULATION DIAMETER RANGE	
4.30-5.30 mm [1.69-.209 IN]		∅2.20-2.80 mm [1.087-.110 IN]	
TERMINAL APPLICATION SPECIFICATION	(A)114-5148 (B)114-78024	(C)114-78030	-

TERMINALS APPLIED			
TE TERMINAL	TE TERMINAL	TE TERMINAL	TE TERMINAL
(A) 917484-2	(A) 1-917484-2	(A) 917484-3	(A) 1-917484-3
(A) 1-917484-5	(A) 917485-2	(A) 917485-3	(A) 917485-5
(B) 2316815-4	(C) 2298107-4		

WIRE SIZE	CRIMP HEIGHT mm [INCH]	CRIMP HEIGHT REFERENCE SETTING
14 AWG OR 2.20mm <sup>2</sup>	1.68+/-0.05 [1.066+/-0.02]	5.3
16 AWG OR 1.25mm <sup>2</sup>	1.45+/-0.05 [1.057+/-0.02]	7.7



- 1. RECOMMENDED SPARE PARTS
- 2. REFER TO SUPPLIED INSTRUCTION SHEET FOR CLEANING, LUBRICATION AND STORAGE OF APPLICATOR.
- 3. APPLY PART NUMBER 2-23419-6 LOCTITE TO THREADS OF ITEM 242.
- 4. CRIMP HEIGHT REFERENCE SETTING WAS THE SETTING USED WHEN THE APPLICATOR WAS QUALIFIED AT THE FACTORY. ADJUSTMENT MAY BE NECESSARY WHEN RUNNING APPLICATOR IN THE FIELD.
- 5. TERMINAL LUBRICANT IS RECOMMENDED.
- 6. UNLESS SPECIFIED OTHERWISE TORQUE VALUES SHALL BE USED PER DOCUMENT, 101-35000.

**\*WARNING**  
 ON INSTALLATION, SET WIRE DISC TO CRIMP HEIGHT REFERENCE SETTING FOR LARGEST WIRE SIZE. CRIMP HEIGHT REFERENCE SETTINGS GREATER THAN THE VALUE SHOWN MAY CAUSE DAMAGE TO THE CRIMP TOOLING. REFER TO THE INSTRUCTION SHEET FOR PROPER SETUP AND ADJUSTMENTS.

LOC	DIST	REV	DATE	BY	APPV
A	66				

REV	DATE	BY	APPV	DESCRIPTION	ITEM NO
-	1	-		2119640-1 PUSH ROD, AIR FEED	250
-	1	-		2079988-1 BUSHING, LCH5-12, MISUMI	249
-	1	1		2119082-9 CAM, SNAIL, INSULATION ADJUSTMENT	244
-	1	1		2079764-1 WASHER, WAVE SPRING, CREST-TO-CREST	243
-	1	1		2119083-1 RETAINER, INSULATION DIAL	242
-	1	1		7-18023-7 SCR, SKT HD CAP M3 X 4.0	241
-	-	1		2119580-1 MECHANICAL FEED ASSEMBLY	239
-	1	-		2063440-1 AIR FEED MODULE	238
-	2	-		21045-3 RING, RETAIN, EXTERN, 3/16 CRESCENT	172
-	REF	REF		994970-2 COUNTER, MAGNETIC	164
-	1	-		240638-1 SPRING, FEED FINGER	163
-	1	-		2119641-2 FEED CAM, AIR FEED	151
-	1	1		2168083-8 SCR, SKT HD CAP, RoHS, M4 X 16	144
-	4	4		2168083-9 SCR, SKT HD CAP, RoHS, M4 X 20	143
-	1	1		1-1803583-0 APPLICATOR BASIC ASSEMBLY, SF	141
-	1	1		1803516-1 RAM ASSEMBLY, SF PACIFIC	140
-	1	-		3-23627-7 PIN, RETAIN, GRVD, 3/16 X .854	137
-	1	-		2119799-1 HOLDER, FEED FINGER, AF	136
-	1	1		1-18028-2 WASHER, FLAT, REG M4	119
-	1	1		2119955-1 ASSY, LUBRICATOR, SIDE FEED	113
-	1	1		2844908-1 SCREW, LOCKING	99
-	1	1		2844907-1 POST, LOCKING	98
-	1	1		455888-4 SPACER, CRIMPER	82
-	1	1		5-547505-2 SPRING, COMPRESSION	77
-	1	1		854769-4 HOLDER, INS	74
-	1	1		1803607-1 DOCUMENTATION PACKAGE	71
-	1	1		2119740-1 TAG, IDENTIFICATION	67
-	2	2		2168078-1 SCREW, DRIVE, RH, RoHS, 2 x .188	66
-	1	1		5-18022-5 SCR, HEX HD CAP, M4 X 6.0	59
-	1	1		21028-2 PIN, SLOTTED SPRING .062 X .250	58
-	1	1		1338685-1 PAWL, FEED	56
-	2	2		1-2168083-0 SCR, SKT HD CAP, RoHS, M4 X 10	53
-	1	1		5018030-1 NUT, HEX, REG, RoHS, M3	52
-	1	1		811242-5 BUMPER, HOLD DOWN	51
-	1	1		690753-2 SPACER, TONKER	50
-	1	2		18023-9 SCR, SKT HD CAP M4 X 6.0	49
-	-	1		2119652-1 FEED CAM, PRE FEED	48
-	1	1		2119653-2 FEED CAM, POST FEED	47
-	1	1		1803602-1 SCR, BHSC, RoHS (M8 X 25)	41
-	1	1		1752356-3 SUPPORT, TERMINAL	34
-	2	2		2079383-5 SCR, BHSC, RoHS (M4 X 20)	33
-	2	2		2-2844962-8 SPACER, CYLINDRICAL, STRIP GUIDE	30
-	1	1		2844992-1 ASSEMBLY, STRIP GUIDE	29
-	1	1		1-455888-0 SPACER, CRIMPER	28
-	1	1		1320928-6 STRIP GUIDE	24
-	1	1		2168083-2 SCR, SKT HD CAP, RoHS, M4 X 8.0	21
-	1	1		1-18028-2 WASHER, FLAT, REG M4	20
-	1	1		2119533-3 STRIPPER, SIDE FEED	19
-	1	1		2119806-1 INSERT, SHEAR	13
-	1	1		3-22280-3 SPRING, COMPRESSION	12
-	1	1		1-356885-4 STOP, SHEAR	11
-	1	1		2119805-1 SHEAR HOLDER, FRONT	10
-	1	1		1803095-1 FLOATING SHEAR, FRONT	9
1	1	1		2-1333206-5 ANVIL, COMBINATION .100	8
-	1	1		2119780-9 DEPRESSOR, SHEAR	5
-	1	1		2-238011-2 BLOCK, CRIMPER SPACER	4
1	1	1		2-2119582-1 CRIMPER, INSULATION F PREMIUM	3
-	1	1		455888-6 SPACER, CRIMPER	2
1	1	1		1-456407-4 CRIMPER, WIRE PREMIUM	1

DIMENSIONS:		TOLERANCES UNLESS OTHERWISE SPECIFIED:		MATERIAL:		FINISH:	
mm	0 PLC ±	1 PLC ±	2 PLC ±	3 PLC ±	4 PLC ±	ANGLES	

DATE	08JUN2011	BY	S.ZOU	APPV	S.XI
DATE	08JUN2011	BY	G.BAILEY	APPV	S.XI

NAME	Ocean Side Feed Applicator	
SIZE	CAGE CODE	DRAWING NO
A1	00779	2151119

Customer Accessible Production Drawing SCALE 1:2 SHEET 3 OF 4 REV E

PACIFIC VERSION  
 Shown on sheets 3 of 4 & 4 of 4  
 (Atlantic version shown on sheets 1 of 4 & 2 of 4)

LOC		DIST		REVISIONS			
A	66	P	LTM	DESCRIPTION	DATE	DMN	APVD
-	-	-	-	SEE SHEET 1	-	-	-

# FEED TYPE MECHANICAL



# PNEUMATIC

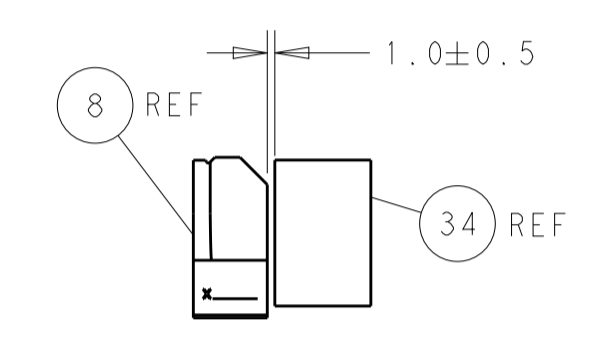
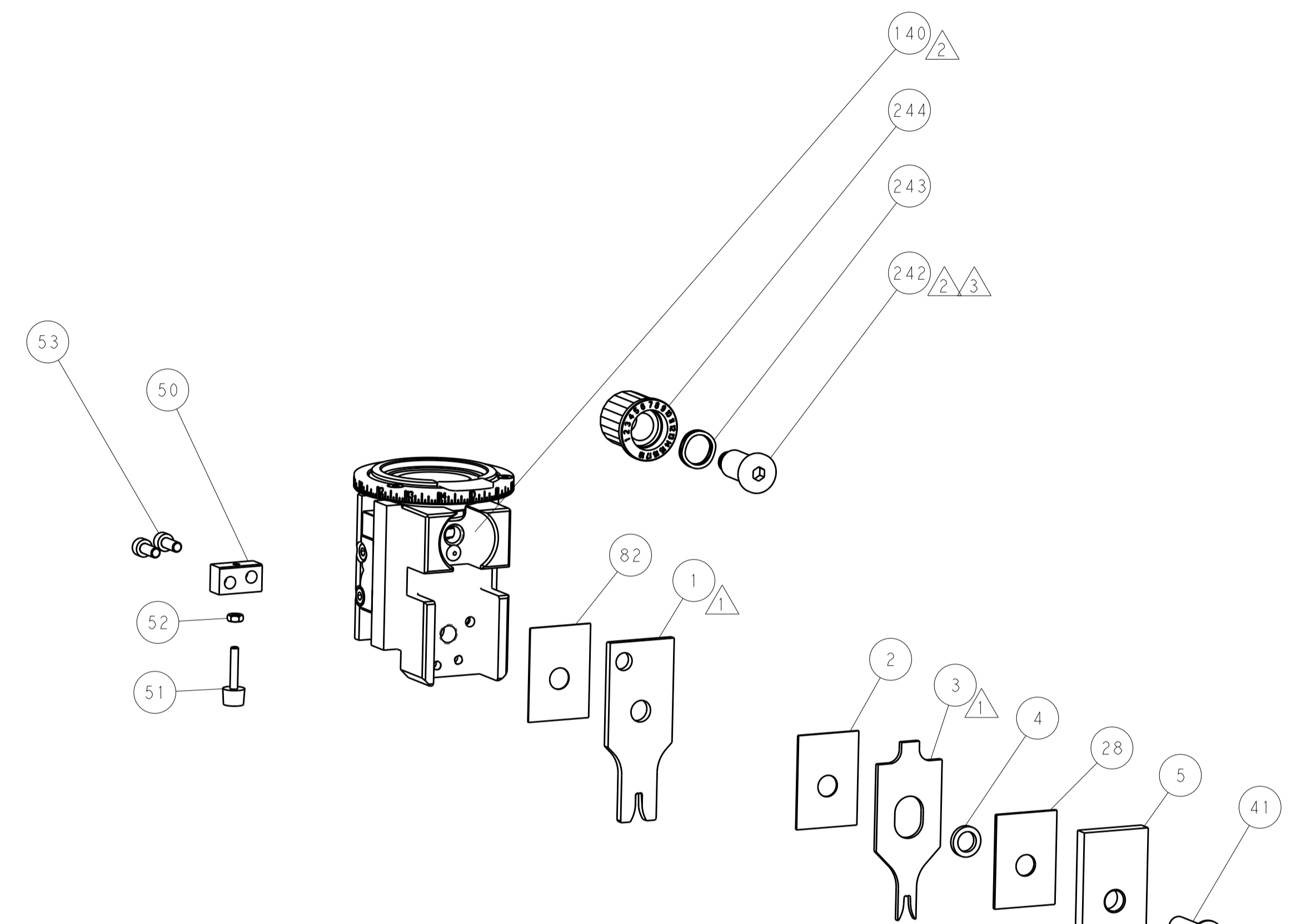

TERMINAL SUPPORT LOCATION

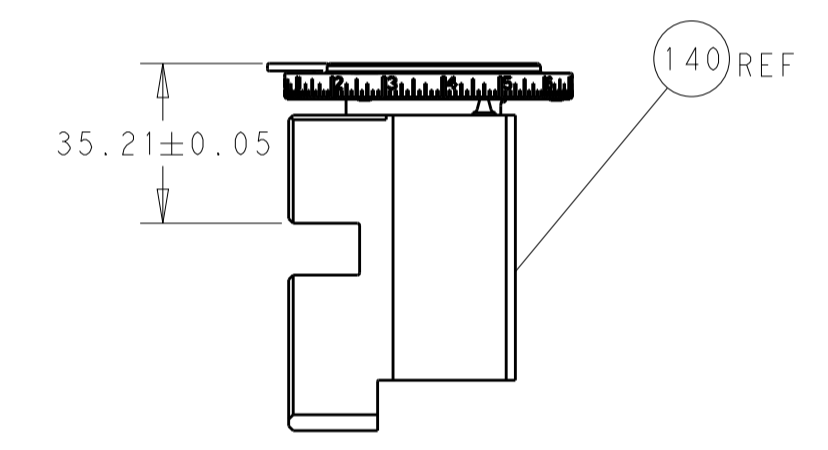

RAM SET-UP

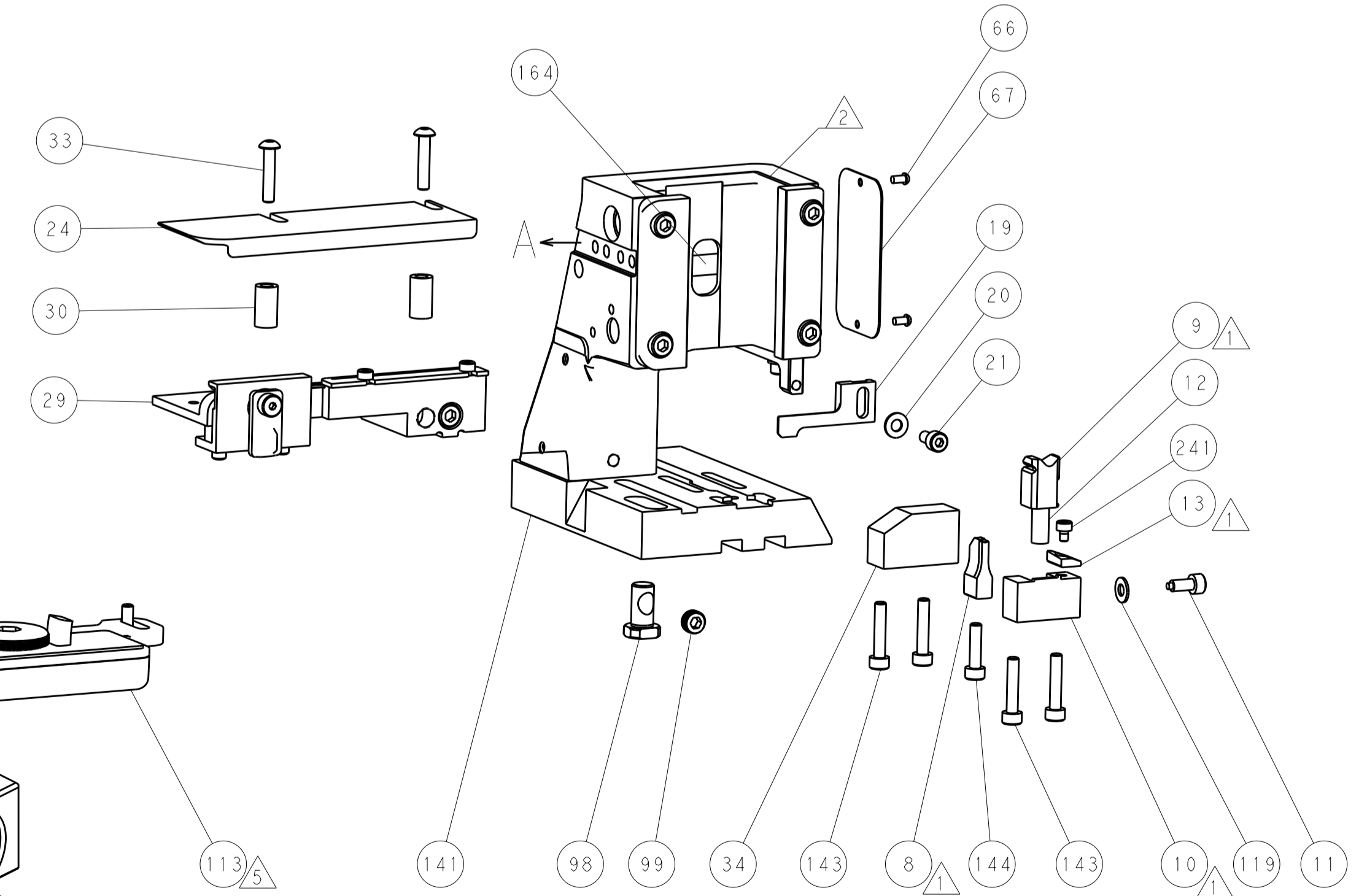

# CAM POSITIONS

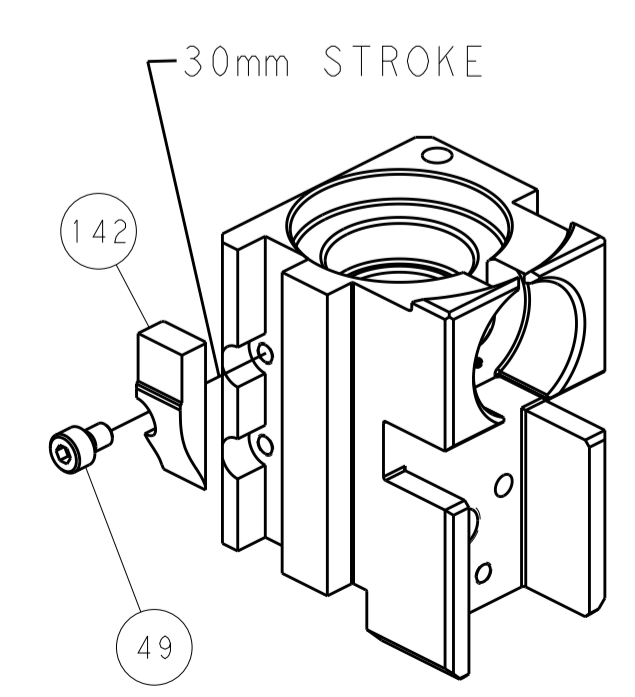

MECHANICAL POST FEED

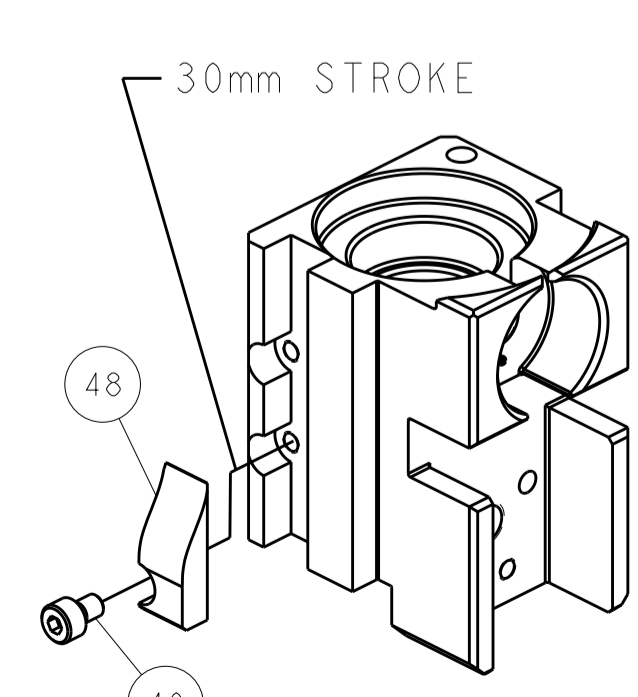

MECHANICAL PRE FEED

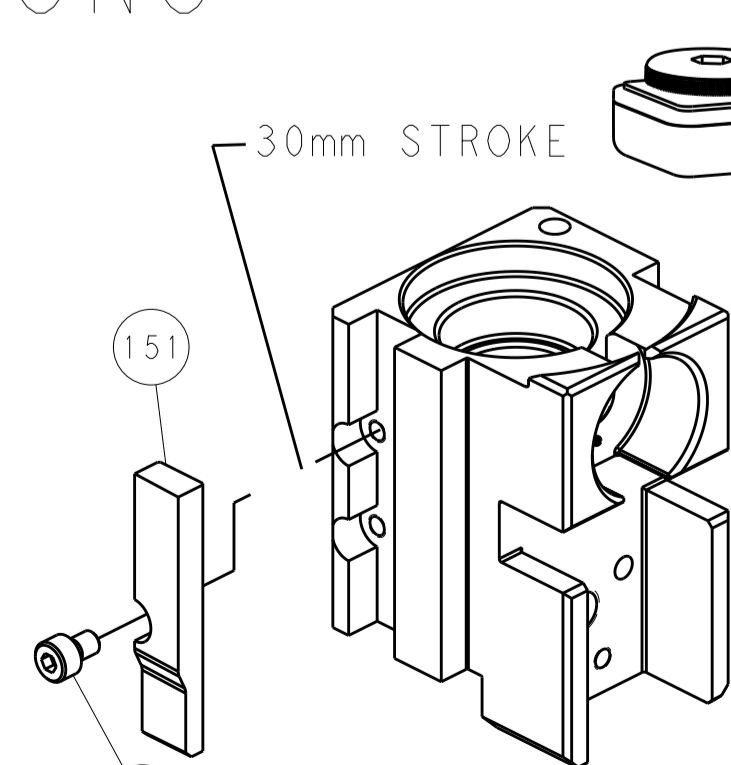

AIR FEED

**PACIFIC VERSION**  
 Shown on sheets 3 of 4 & 4 of 4  
 (Atlantic version shown on sheets 1 of 4 & 2 of 4)

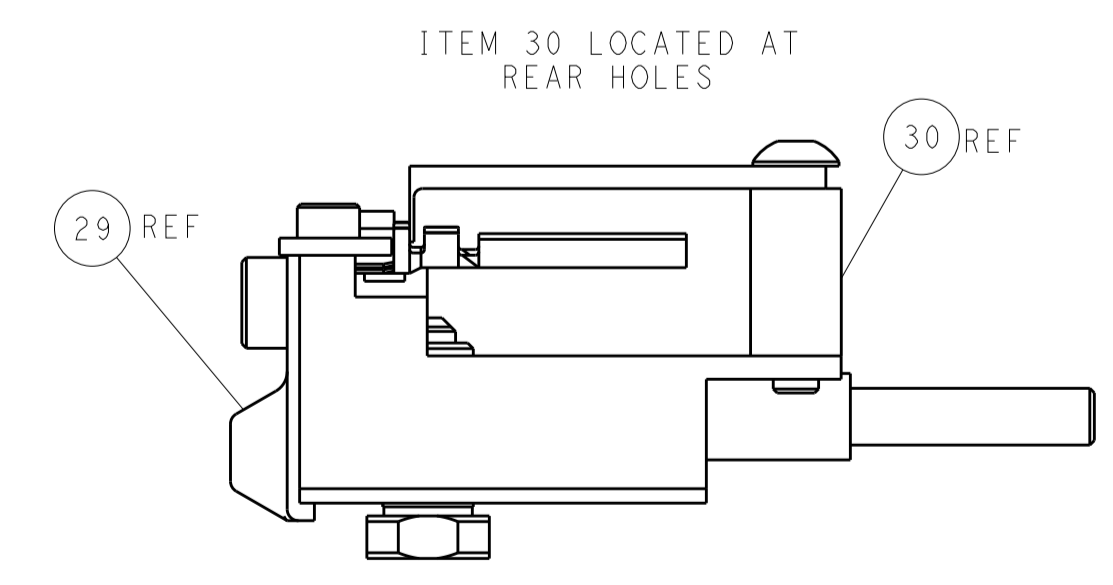

FEED TRACK POSITION GUIDE BY INSULATION BARREL

DIMENSIONS:		TOLERANCES UNLESS OTHERWISE SPECIFIED:		DWG: S_ZOU 08JUN2011		TE Connectivity	
mm	0 PLC ±	1 PLC ±	2 PLC ±	3 PLC ±	4 PLC ±	Harrisburg, PA 17105-3608	
MATERIAL:		FINISH:		CHK: G_BAILEY 08JUN2011		NAME: Ocean Side Feed Applicator	
				APVD: S_XI 08JUN2011		SIZE: CAGE CODE: DRAWING NO: RESTRICTED TO	
				PRODUCT SPEC:		A1 00779 ©=2151119	
				APPLICATION SPEC:		Customer Accessible Production Drawing	
				WEIGHT:		SCALE: 1:2 SHEET 4 OF 4 REV E	