

**High-Speed CMOS Logic
Dual Monostable Multivibrator with Reset**

Features

- Overriding RESET Terminates Output Pulse
- Triggering from the Leading or Trailing Edge
- Q and \bar{Q} Buffered Outputs
- Separate Resets
- Wide Range of Output-Pulse Widths
- Schmitt Trigger on B Inputs
- Fanout (Over Temperature Range)
 - Standard Outputs 10 LSTTL Loads
 - Bus Driver Outputs 15 LSTTL Loads
- Wide Operating Temperature Range . . . -55°C to 125°C
- Balanced Propagation Delay and Transition Times
- Significant Power Reduction Compared to LSTTL Logic ICs
- HC Types
 - 2V to 6V Operation
 - High Noise Immunity: $N_{IL} = 30\%$, $N_{IH} = 30\%$ of V_{CC} at $V_{CC} = 5V$
- HCT Types
 - 4.5V to 5.5V Operation
 - Direct LSTTL Input Logic Compatibility, $V_{IL} = 0.8V$ (Max), $V_{IH} = 2V$ (Min)
 - CMOS Input Compatibility, $I_I \leq 1\mu A$ at V_{OL} , V_{OH}

Description

The 'HC221 and CD74HCT221 are dual monostable multivibrators with reset. An external resistor (R_X) and an external capacitor (C_X) control the timing and the accuracy for the circuit. Adjustment of R_X and C_X provides a wide range of output pulse widths from the Q and \bar{Q} terminals. Pulse triggering on the B input occurs at a particular voltage level and is not related to the rise and fall time of the trigger pulse.

Once triggered, the outputs are independent of further trigger inputs on A and B. The output pulse can be terminated by a LOW level on the Reset (\bar{R}) pin. Trailing Edge triggering (\bar{A}) and leading-edge-triggering (B) inputs are provided for triggering from either edge of the input pulse. On power up, the IC is reset. If either Mono is not used each input (on the unused device) must be terminated either high or low.

The minimum value of external resistance, R_X , is typically 500Ω. The minimum value of external capacitance, C_X , is 0pF. The calculation for the pulse width is $t_W = 0.7 R_X C_X$ at $V_{CC} = 4.5V$.

Ordering Information

PART NUMBER	TEMP. RANGE (°C)	PACKAGE
CD54HC221F3A	-55 to 125	16 Ld CERDIP
CD74HC221E	-55 to 125	16 Ld PDIP
CD74HC221M	-55 to 125	16 Ld SOIC
CD74HC221MT	-55 to 125	16 Ld SOIC
CD74HC221M96	-55 to 125	16 Ld SOIC
CD74HC221NSR	-55 to 125	16 Ld SOP
CD74HC221PW	-55 to 125	16 Ld TSSOP
CD74HC221PWR	-55 to 125	16 Ld TSSOP
CD74HC221PWT	-55 to 125	16 Ld TSSOP
CD74HCT221E	-55 to 125	16 Ld PDIP
CD74HCT221M	-55 to 125	16 Ld SOIC
CD74HCT221MT	-55 to 125	16 Ld SOIC
CD74HCT221M96	-55 to 125	16 Ld SOIC

NOTE: When ordering, use the entire part number. The suffixes 96 and R denote tape and reel. The suffix T denotes a small-quantity reel of 250.



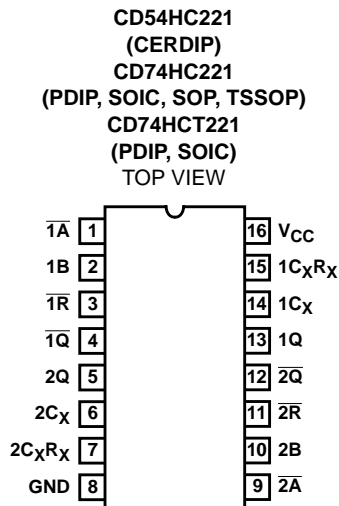

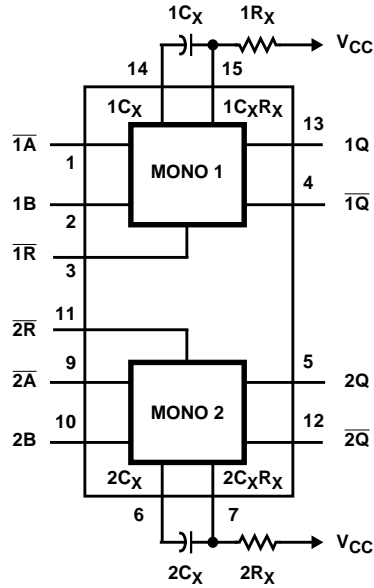

Pinout





Functional Diagram



TRUTH TABLE

INPUTS			OUTPUTS	
\bar{A}	B	\bar{R}	Q	\bar{Q}
H	X	H	L	H
X	L	H	L	H
L	↑	H		
↓	H	H		
X	X	L	L	H
L	H	↑	 (Note 3)	 (Note 3)

H = High Voltage Level, L = Low Voltage Level, X = Irrelevant, ↑ = Transition from Low to High Level, ↓ = Transition from High to Low Level,  = One High Level Pulse,  = One Low Level Pulse

NOTE:

- For this combination the reset input must be low and the following sequence must be used: pin 1 (or 9) must be set high or pin 2 (or 10) set low; then pin 1 (or 9) must be low and pin 2 (or 10) set high. Now the reset input goes from low-to-high and the device will be triggered.

Logic Diagram



CD54HC221, CD74HC221, CD74HCT221

Absolute Maximum Ratings

DC Supply Voltage, V_{CC}	-0.5V to 7V
DC Input Diode Current, I_{IK}	
For $V_I < -0.5V$ or $V_I > V_{CC} + 0.5V$	$\pm 20mA$
DC Output Diode Current, I_{OK}	
For $V_O < -0.5V$ or $V_O > V_{CC} + 0.5V$	$\pm 20mA$
DC Drain Current, per Output, I_O	
For $-0.5V < V_O < V_{CC} + 0.5V$	$\pm 25mA$
DC Output Source or Sink Current per Output Pin, I_O	
For $V_O > -0.5V$ or $V_O < V_{CC} + 0.5V$	$\pm 25mA$
DC V_{CC} or Ground Current, I_{CC}	$\pm 50mA$

Thermal Information

Package Thermal Impedance, θ_{JA} (see Note 2):	
E (PDIP) Package	67°C/W
M (SOIC) Package	73°C/W
NS (SOP) Package	64°C/W
PW (TSSOP) Package	108°C/W
Maximum Junction Temperature (Plastic Package)	150°C
Maximum Storage Temperature Range	-65°C to 150°C
Maximum Lead Temperature (Soldering 10s)	300°C
(SOIC - Lead Tips Only)	

Operating Conditions

Temperature Range, T_A	-55°C to 125°C
Supply Voltage Range, V_{CC}	
HC Types2V to 6V
HCT Types	4.5V to 5.5V
DC Input or Output Voltage, V_I, V_O	0V to V_{CC}
Input Rise and Fall Time, t_r, t_f on Inputs \bar{A} and \bar{R}	
2V	1000ns (Max)
4.5V	500ns (Max)
6V	400ns (Max)
Input Rise and Fall Time, t_r, t_f on Input B	
2V	Unlimited ns (Max)
4.5V	Unlimited ns (Max)
6V	Unlimited ns (Max)

CAUTION: Stresses above those listed in "Absolute Maximum Ratings" may cause permanent damage to the device. This is a stress only rating and operation of the device at these or any other conditions above those indicated in the operational sections of this specification is not implied.

NOTE:

- The package thermal impedance is calculated in accordance with JESD 51-7.

DC Electrical Specifications

PARAMETER	SYMBOL	TEST CONDITIONS		V_{CC} (V)	25°C			-40°C TO 85°C		-55°C TO 125°C		UNITS
		V_I (V)	I_O (mA)		MIN	TYP	MAX	MIN	MAX	MIN	MAX	
HC TYPES												
High Level Input Voltage	V_{IH}	-	-	2	1.5	-	-	1.5	-	1.5	-	V
				4.5	3.15	-	-	3.15	-	3.15	-	V
				6	4.2	-	-	4.2	-	4.2	-	V
Low Level Input Voltage	V_{IL}	-	-	2	-	-	0.5	-	0.5	-	0.5	V
				4.5	-	-	1.35	-	1.35	-	1.35	V
				6	-	-	1.8	-	1.8	-	1.8	V
High Level Output Voltage CMOS Loads	V_{OH}	V_{IH} or V_{IL}	-0.02	2	1.9	-	-	1.9	-	1.9	-	V
			-0.02	4.5	4.4	-	-	4.4	-	4.4	-	V
			-0.02	6	5.9	-	-	5.9	-	5.9	-	V
High Level Output Voltage TTL Loads	V_{OH}	V_{IH} or V_{IL}	-	-	-	-	-	-	-	-	-	V
			-4	4.5	3.98	-	-	3.84	-	3.7	-	V
			-5.2	6	5.48	-	-	5.34	-	5.2	-	V
Low Level Output Voltage CMOS Loads	V_{OL}	V_{IH} or V_{IL}	0.02	2	-	-	0.1	-	0.1	-	0.1	V
			0.02	4.5	-	-	0.1	-	0.1	-	0.1	V
			0.02	6	-	-	0.1	-	0.1	-	0.1	V
Low Level Output Voltage TTL Loads	V_{OL}	V_{IH} or V_{IL}	-	-	-	-	-	-	-	-	-	V
			4	4.5	-	-	0.26	-	0.33	-	0.4	V
			5.2	6	-	-	0.26	-	0.33	-	0.4	V

CD54HC221, CD74HC221, CD74HCT221

DC Electrical Specifications (Continued)

PARAMETER	SYMBOL	TEST CONDITIONS		V _{CC} (V)	25°C			-40°C TO 85°C		-55°C TO 125°C		UNITS
		V _I (V)	I _O (mA)		MIN	TYP	MAX	MIN	MAX	MIN	MAX	
Input Leakage Current	I _I	V _{CC} or GND	-	6	-	-	±0.1	-	±1	-	±1	μA
Quiescent Device Current	I _{CC}	V _{CC} or GND	0	6	-	-	8	-	80	-	160	μA
HCT TYPES												
High Level Input Voltage	V _{IH}	-	-	4.5 to 5.5	2	-	-	2	-	2	-	V
Low Level Input Voltage	V _{IL}	-	-	4.5 to 5.5	-	-	0.8	-	0.8	-	0.8	V
High Level Output Voltage CMOS Loads	V _{OH}	V _{IH} or V _{IL}	-0.02	4.5	4.4	-	-	4.4	-	4.4	-	V
High Level Output Voltage TTL Loads			-4	4.5	3.98	-	-	3.84	-	3.7	-	V
Low Level Output Voltage CMOS Loads	V _{OL}	V _{IH} or V _{IL}	0.02	4.5	-	-	0.1	-	0.1	-	0.1	V
Low Level Output Voltage TTL Loads			4	4.5	-	-	0.26	-	0.33	-	0.4	V
Input Leakage Current	I _I	V _{CC} and GND	0	5.5	-	-	±0.1	-	±1	-	±1	μA
Quiescent Device Current	I _{CC}	V _{CC} or GND	0	5.5	-	-	8	-	80	-	160	μA
Additional Quiescent Device Current Per Input Pin: 1 Unit Load	ΔI _{CC} (Note 3)	V _{CC} -2.1	-	4.5 to 5.5	-	100	360	-	450	-	490	μA

NOTE:

3. For dual-supply systems theoretical worst case (V_I = 2.4V, V_{CC} = 5.5V) specification is 1.8mA.

HCT Input Loading Table

INPUT	UNIT LOADS
All Inputs	0.3

NOTE: Unit Load is ΔI_{CC} limit specified in DC Electrical Table, e.g., 360μA max at 25°C.

Prerequisite For Switching Function

PARAMETER	SYMBOL	V _{CC} (V)	25°C			-40°C TO 85°C		-55°C TO 125°C		UNITS
			MIN	TYP	MAX	MIN	MAX	MIN	MAX	
HC TYPES										
Input Pulse Width A	t _{WL}	2	70	-	-	90	-	105	-	ns
		4.5	14	-	-	18	-	21	-	ns
		6	12	-	-	15	-	18	-	ns
Input Pulse Width B	t _{WH}	2	70	-	-	90	-	105	-	ns
		4.5	14	-	-	18	-	21	-	ns
		6	12	-	-	15	-	18	-	ns

CD54HC221, CD74HC221, CD74HCT221

Prerequisite For Switching Function (Continued)

PARAMETER	SYMBOL	V _{CC} (V)	25°C			-40°C TO 85°C		-55°C TO 125°C		UNITS
			MIN	TYP	MAX	MIN	MAX	MIN	MAX	
Input Pulse Width Reset	t _{WL}	2	70	-	-	90	-	105	-	ns
		4.5	14	-	-	18	-	21	-	ns
		6	12	-	-	15	-	18	-	ns
Recovery Time R̄ to Ā or B	t _{SU}	2	0	-	-	0	-	0	-	ns
		4.5	0	-	-	0	-	0	-	ns
		6	0	-	-	0	-	0	-	ns
Output Pulse Width Q or Q̄ C _X = 0.1μF R _X = 10kΩ	t _W	5	630	-	770	602	798	595	805	μs
Output Pulse Width Q or Q̄ C _X = 28pF, R _X = 2kΩ	t _W	4.5	-	140	-	-	-	-	-	ns
C _X = 1000pF, R _X = 2kΩ	t _W	4.5	-	1.5	-	-	-	-	-	μs
C _X = 1000pF, R _X = 10kΩ	t _W	4.5	-	7	-	-	-	-	-	μs

HCT TYPES

Input Pulse Width A	t _{WL}	4.5	14	-	-	18	-	21	-	ns
Input Pulse Width B	t _{WH}	4.5	14	-	-	18	-	21	-	ns
Input Pulse Width Reset	t _{WL}	4.5	18	-	-	23	-	27	-	ns
Recovery Time R̄ to Ā or B	t _{SU}	4.5	0	-	-	0	-	0	-	ns
Output Pulse Width Q or Q̄ C _X = 0.1μF R _X = 10kΩ	t _W	5	630	-	770	602	798	595	805	μs
Output Pulse Width Q or Q̄ C _X = 28pF, R _X = 2kΩ	t _W	4.5	-	140	-	-	-	-	-	ns
C _X = 1000pF, R _X = 2kΩ	t _W	4.5	-	1.5	-	-	-	-	-	μs
C _X = 1000pF, R _X = 10kΩ	t _W	4.5	-	7	-	-	-	-	-	μs

Switching Specifications Input t_r, t_f = 6ns

PARAMETER	SYMBOL	TEST CONDITIONS	V _{CC} (V)	25°C			-40°C TO 85°C		-55°C TO 125°C		UNITS
				MIN	TYP	MAX	MIN	MAX	MIN	MAX	
HC TYPES											
Propagation Delay, Trigger Ā, B, R̄ to Q	t _{PLH}	C _L = 50pF	2	-	-	210	-	265	-	315	ns
		C _L = 50pF	4.5	-	-	42	-	53	-	63	ns
		C _L = 50pF	6	-	-	36	-	45	-	54	ns
		C _L = 15pF	5	-	18	-	-	-	-	-	ns
Propagation Delay, Trigger Ā, B, R̄ to Q̄	t _{PHL}	C _L = 50pF	2	-	-	170	-	215	-	255	ns
		C _L = 50pF	4.5	-	-	34	-	43	-	51	ns
		C _L = 50pF	6	-	-	29	-	37	-	43	ns
		C _L = 15pF	5	-	14	-	-	-	-	-	ns

CD54HC221, CD74HC221, CD74HCT221

Switching Specifications Input t_r , $t_f = 6\text{ns}$ (Continued)

PARAMETER	SYMBOL	TEST CONDITIONS	V_{CC} (V)	25°C			-40°C TO 85°C		-55°C TO 125°C		UNITS
				MIN	TYP	MAX	MIN	MAX	MIN	MAX	
Propagation Delay, \bar{R} to Q	t_{PLH}	$C_L = 50\text{pF}$	2	-	-	160	-	200	-	240	ns
			4.5	-	-	32	-	40	-	48	ns
			6	-	-	27	-	34	-	41	ns
Propagation Delay, \bar{R} to \bar{Q}	t_{PHL}	$C_L = 50\text{pF}$	2	-	-	180	-	225	-	270	ns
			4.5	-	-	36	-	45	-	54	ns
			6	-	-	31	-	38	-	46	ns
Output Transition Time	t_{TLH}, t_{THL}	$C_L = 50\text{pF}$	2	-	-	75	-	95	-	110	ns
			4.5	-	-	15	-	19	-	22	ns
			6	-	-	13	-	16	-	19	ns
Input Capacitance	C_{IN}	-	-	-	10	-	10	-	10	pF	
Pulse Width Match Between Circuits in the Same Package $C_X = 1000\text{pF}$, $R_X = 10\text{k}\Omega$		-	4.5 to 5.5	-	± 2	-	-	-	-	-	%
Power Dissipation Capacitance (Notes 4, 5)	CPD	-	5	-	166	-	-	-	-	-	pF
HCT TYPES											
Propagation Delay, Trigger A, B, \bar{R} to Q	t_{PLH}	$C_L = 50\text{pF}$	4.5	-	-	42	-	-	-	63	ns
		$C_L = 15\text{pF}$	5	-	18	-	-	-	-	-	ns
Propagation Delay, Trigger \bar{A} , B, \bar{R} to \bar{Q}	t_{PHL}	$C_L = 50\text{pF}$	4.5	-	-	34	-	43	-	51	ns
		$C_L = 15\text{pF}$	5	-	14	-	-	-	-	-	ns
Propagation Delay, \bar{R} to Q	t_{PLH}	$C_L = 50\text{pF}$	4.5	-	-	38	-	-	-	57	ns
Propagation Delay, \bar{R} to \bar{Q}	t_{PHL}	$C_L = 50\text{pF}$	4.5	-	-	37	-	-	-	56	ns
Output Transition Time	t_{TLH}, t_{THL}	$C_L = 50\text{pF}$	2	-	-	75	-	95	-	110	ns
			4.5	-	-	15	-	19	-	22	ns
			6	-	-	13	-	16	-	19	ns
Input Capacitance	C_{IN}	-	-	-	10	-	10	-	10	pF	
Pulse Width Match Between Circuits in the Same Package $C_X = 1000\text{pF}$, $R_X = 10\text{k}\Omega$		-	4.5 to 5.5	-	± 2	-	-	-	-	-	%
Power Dissipation Capacitance (Notes 4, 5)	CPD	-	5	-	166	-	-	-	-	-	pF

NOTES:

4. C_{PD} is used to determine the dynamic power consumption, per multivibrator.
5. $P_D = (C_{PD} + C_L) V_{CC}^2 f_i + \Sigma$ where f_i = input frequency, f_o = output frequency, C_L = output load capacitance, V_{CC} = supply voltage.

Test Circuits and Waveforms



NOTE: Outputs should be switching from 10% V_{CC} to 90% V_{CC} in accordance with device truth table. For f_{MAX} , input duty cycle = 50%.

FIGURE 1. HC CLOCK PULSE RISE AND FALL TIMES AND PULSE WIDTH



NOTE: Outputs should be switching from 10% V_{CC} to 90% V_{CC} in accordance with device truth table. For f_{MAX} , input duty cycle = 50%.

FIGURE 2. HCT CLOCK PULSE RISE AND FALL TIMES AND PULSE WIDTH



FIGURE 3. HC TRANSITION TIMES AND PROPAGATION DELAY TIMES, COMBINATION LOGIC

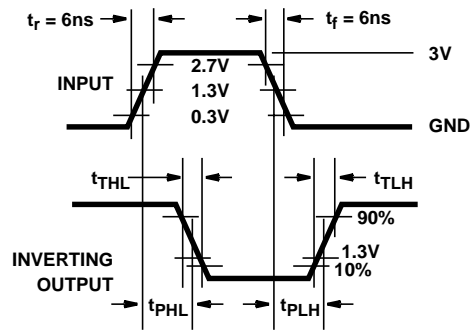

FIGURE 4. HCT TRANSITION TIMES AND PROPAGATION DELAY TIMES, COMBINATION LOGIC

Typical Performance Curves



FIGURE 5. HC/HCT221 OUTPUT PULSE WIDTH vs TEMPERATURE



FIGURE 6. HC/HCT221 K FACTOR vs SUPPLY VOLTAGE



FIGURE 7. HC221 OUTPUT PULSE WIDTH vs C_X



FIGURE 8. HC/HCT221 OUTPUT PULSE WIDTH vs C_X

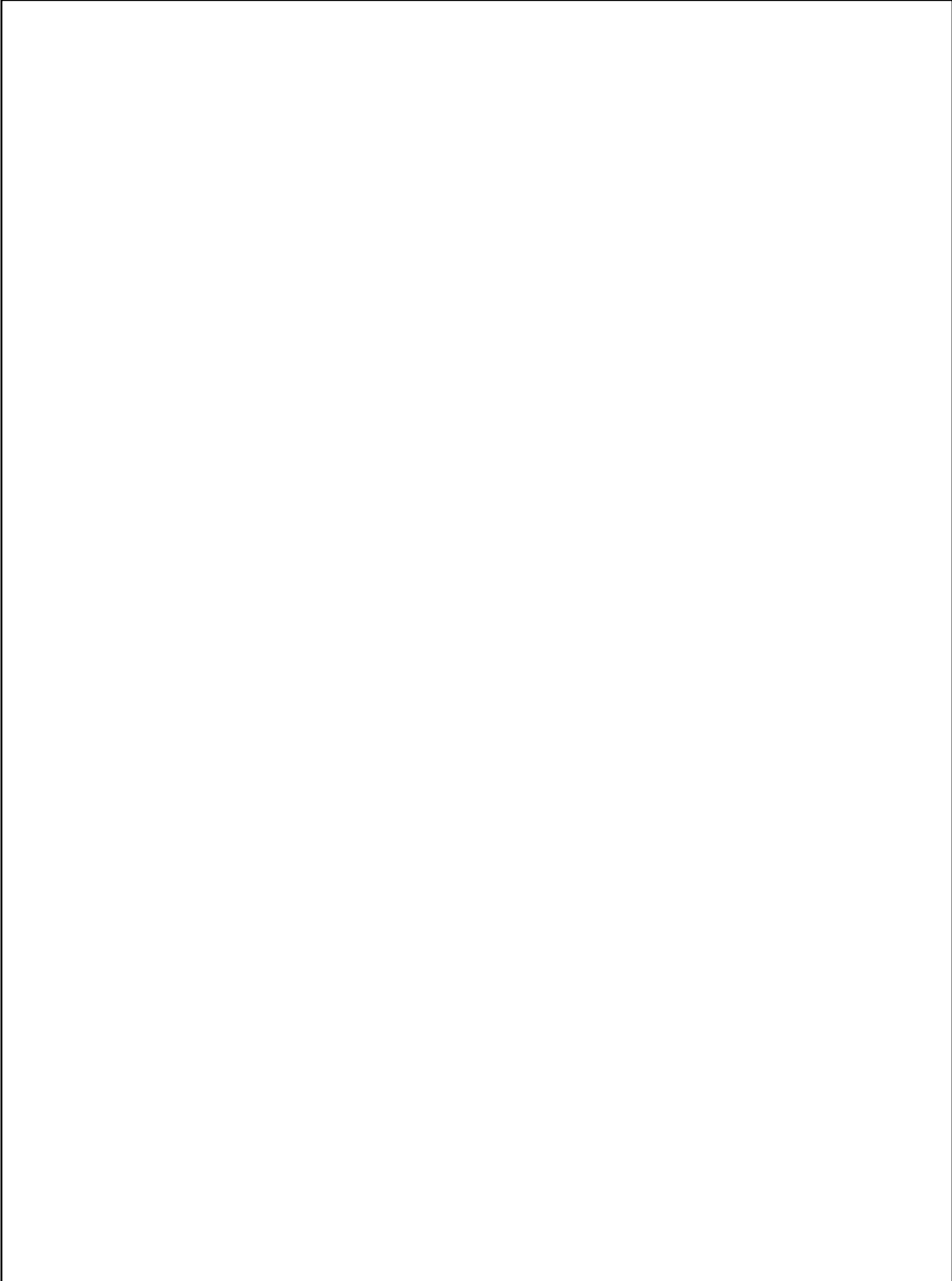

J (R-GDIP-T**)

14 LEADS SHOWN

CERAMIC DUAL IN-LINE PACKAGE



DIM \ PINS **	14	16	18	20
A	0.300 (7,62) BSC	0.300 (7,62) BSC	0.300 (7,62) BSC	0.300 (7,62) BSC
B MAX	0.785 (19,94)	.840 (21,34)	0.960 (24,38)	1.060 (26,92)
B MIN	—	—	—	—
C MAX	0.300 (7,62)	0.300 (7,62)	0.310 (7,87)	0.300 (7,62)
C MIN	0.245 (6,22)	0.245 (6,22)	0.220 (5,59)	0.245 (6,22)



4040083/F 03/03

- NOTES:
- All linear dimensions are in inches (millimeters).
 - This drawing is subject to change without notice.
 - This package is hermetically sealed with a ceramic lid using glass frit.
 - Index point is provided on cap for terminal identification only on press ceramic glass frit seal only.
 - Falls within MIL STD 1835 GDIP1-T14, GDIP1-T16, GDIP1-T18 and GDIP1-T20.

N (R-PDIP-T**)

PLASTIC DUAL-IN-LINE PACKAGE

16 PINS SHOWN



- NOTES:
- A. All linear dimensions are in inches (millimeters).
 - B. This drawing is subject to change without notice.
 - $\triangle C$ Falls within JEDEC MS-001, except 18 and 20 pin minimum body length (Dim A).
 - $\triangle D$ The 20 pin end lead shoulder width is a vendor option, either half or full width.

D (R-PDSO-G16)

PLASTIC SMALL-OUTLINE PACKAGE



- NOTES:
- A. All linear dimensions are in inches (millimeters).
 - B. This drawing is subject to change without notice.
 - C. Body dimensions do not include mold flash or protrusion not to exceed 0.006 (0,15).
 - D. Falls within JEDEC MS-012 variation AC.

MECHANICAL DATA

NS (R-PDSO-G**)

PLASTIC SMALL-OUTLINE PACKAGE

14-PINS SHOWN



- NOTES:
- A. All linear dimensions are in millimeters.
 - B. This drawing is subject to change without notice.
 - C. Body dimensions do not include mold flash or protrusion, not to exceed 0,15.

PW (R-PDSO-G**)

PLASTIC SMALL-OUTLINE PACKAGE

14 PINS SHOWN



4040064/F 01/97

- NOTES: A. All linear dimensions are in millimeters.
 B. This drawing is subject to change without notice.
 C. Body dimensions do not include mold flash or protrusion not to exceed 0,15.
 D. Falls within JEDEC MO-153

IMPORTANT NOTICE

Texas Instruments Incorporated and its subsidiaries (TI) reserve the right to make corrections, modifications, enhancements, improvements, and other changes to its products and services at any time and to discontinue any product or service without notice. Customers should obtain the latest relevant information before placing orders and should verify that such information is current and complete. All products are sold subject to TI's terms and conditions of sale supplied at the time of order acknowledgment.

TI warrants performance of its hardware products to the specifications applicable at the time of sale in accordance with TI's standard warranty. Testing and other quality control techniques are used to the extent TI deems necessary to support this warranty. Except where mandated by government requirements, testing of all parameters of each product is not necessarily performed.

TI assumes no liability for applications assistance or customer product design. Customers are responsible for their products and applications using TI components. To minimize the risks associated with customer products and applications, customers should provide adequate design and operating safeguards.

TI does not warrant or represent that any license, either express or implied, is granted under any TI patent right, copyright, mask work right, or other TI intellectual property right relating to any combination, machine, or process in which TI products or services are used. Information published by TI regarding third-party products or services does not constitute a license from TI to use such products or services or a warranty or endorsement thereof. Use of such information may require a license from a third party under the patents or other intellectual property of the third party, or a license from TI under the patents or other intellectual property of TI.

Reproduction of information in TI data books or data sheets is permissible only if reproduction is without alteration and is accompanied by all associated warranties, conditions, limitations, and notices. Reproduction of this information with alteration is an unfair and deceptive business practice. TI is not responsible or liable for such altered documentation.

Resale of TI products or services with statements different from or beyond the parameters stated by TI for that product or service voids all express and any implied warranties for the associated TI product or service and is an unfair and deceptive business practice. TI is not responsible or liable for any such statements.

Following are URLs where you can obtain information on other Texas Instruments products and application solutions:

Products		Applications	
Amplifiers	amplifier.ti.com	Audio	www.ti.com/audio
Data Converters	dataconverter.ti.com	Automotive	www.ti.com/automotive
DSP	dsp.ti.com	Broadband	www.ti.com/broadband
Interface	interface.ti.com	Digital Control	www.ti.com/digitalcontrol
Logic	logic.ti.com	Military	www.ti.com/military
Power Mgmt	power.ti.com	Optical Networking	www.ti.com/opticalnetwork
Microcontrollers	microcontroller.ti.com	Security	www.ti.com/security
		Telephony	www.ti.com/telephony
		Video & Imaging	www.ti.com/video
		Wireless	www.ti.com/wireless

Mailing Address: Texas Instruments
Post Office Box 655303 Dallas, Texas 75265