



24-Bit ANALOG-TO-DIGITAL CONVERTER

FEATURES

- 24 BITS NO MISSING CODES
- SIMULTANEOUS 50Hz AND 60Hz REJECTION (–90dB MINIMUM)
- 0.0015% INL
- 21 BITS EFFECTIVE RESOLUTION (PGA = 1), 19 BITS (PGA = 128)
- PGA GAINS FROM 1 TO 128
- SINGLE CYCLE SETTLING
- PROGRAMMABLE DATA OUTPUT RATES
- EXTERNAL DIFFERENTIAL REFERENCE OF 0.1V TO 5V
- ON-CHIP CALIBRATION
- SPI™ COMPATIBLE
- 2.7V TO 5.25V SUPPLY RANGE
- 600µW POWER CONSUMPTION
- UP TO EIGHT INPUT CHANNELS
- UP TO EIGHT DATA I/O

APPLICATIONS

- INDUSTRIAL PROCESS CONTROL
- WEIGH SCALES
- LIQUID/GAS CHROMATOGRAPHY
- BLOOD ANALYSIS
- SMART TRANSMITTERS
- PORTABLE INSTRUMENTATION

DESCRIPTION

The ADS1240 and ADS1241 are precision, wide dynamic range, delta-sigma, Analog-to-Digital (A/D) converters with 24-bit resolution operating from 2.7V to 5.25V power supplies. The delta-sigma A/D converter provides up to 24 bits of no missing code performance and effective resolution of 21 bits.

The input channels are multiplexed. Internal buffering can be selected to provide very high input impedance for direct connection to transducers or low-level voltage signals. Burnout current sources are provided that allow for detection of an open or shorted sensor. An 8-bit Digital-to-Analog (D/A) converter provides an offset correction with a range of 50% of the Full-Scale Range (FSR).

The Programmable Gain Amplifier (PGA) provides selectable gains of 1 to 128, with an effective resolution of 19 bits at a gain of 128. The A/D conversion is accomplished with a 2nd-order delta-sigma modulator and programmable Finite-Impulse Response (FIR) filter that provides a simultaneous 50Hz and 60Hz notch. The reference input is differential and can be used for ratiometric conversion.

The serial interface is SPI compatible. Up to eight bits of data I/O are also provided that can be used for input or output. The ADS1240 and ADS1241 are designed for high-resolution measurement applications in smart transmitters, industrial process control, weigh scales, chromatography, and portable instrumentation.

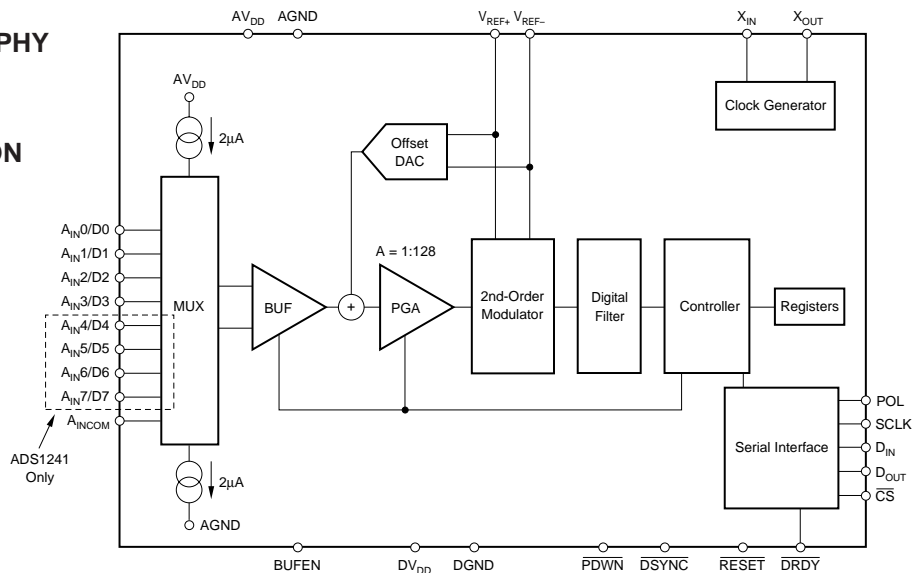

Please be aware that an important notice concerning availability, standard warranty, and use in critical applications of Texas Instruments semiconductor products and disclaimers thereto appears at the end of this data sheet.

All trademarks property of their respective owners.

PRODUCTION DATA information is current as of publication date. Products conform to specifications per the terms of Texas Instruments standard warranty. Production processing does not necessarily include testing of all parameters.

ABSOLUTE MAXIMUM RATINGS⁽¹⁾

AV_{DD} to DGND	-0.3V to +6V
DV_{DD} to DGND	-0.3V to +6V
Input Current	100mA, Momentary
DGND to AGND	-0.3V to 0.3V
Input Current	10mA, Continuous
A_{IN}	AGND -0.5V to AV_{DD} + 0.5V
Digital Input Voltage to DGND	-0.3V to DV_{DD} + 0.3V
Digital Output Voltage to DGND	-0.3V to DV_{DD} + 0.3V
Maximum Junction Temperature	+150°C
Operating Temperature Range	-40°C to +85°C
Storage Temperature Range	-60°C to +150°C

NOTE: (1) Stresses above these ratings may cause permanent damage. Exposure to absolute maximum conditions for extended periods may degrade device reliability.



ELECTROSTATIC DISCHARGE SENSITIVITY

This integrated circuit can be damaged by ESD. Texas Instruments recommends that all integrated circuits be handled with appropriate precautions. Failure to observe proper handling and installation procedures can cause damage.

ESD damage can range from subtle performance degradation to complete device failure. Precision integrated circuits may be more susceptible to damage because very small parametric changes could cause the device not to meet its published specifications.

PACKAGE/ORDERING INFORMATION

For the most current package and ordering information, see the Package Option Addendum at the end of this document, or see the TI website at www.ti.com.

DIGITAL CHARACTERISTICS: -40°C to +85°C, DV_{DD} 2.7V to 5.25V

PARAMETER	CONDITIONS	MIN	TYP	MAX	UNITS
Digital Input/Output Logic Family			CMOS		
Logic Level: V_{IH}		$0.8 \cdot DV_{DD}$		DV_{DD}	V
V_{IL}		DGND		$0.2 \cdot DV_{DD}$	V
V_{OH}	$I_{OH} = 1\text{mA}$	$DV_{DD} - 0.4$			V
V_{OL}	$I_{OL} = 1\text{mA}$	DGND		DGND + 0.4	V
Input Leakage: I_{IH}	$V_I = DV_{DD}$			10	μA
I_{IL}	$V_I = 0$	-10			μA
Master Clock Rate: f_{OSC}		1		5	MHz
Master Clock Period: t_{OSC}	$1/f_{OSC}$	200		1000	ns

ELECTRICAL CHARACTERISTICS: AV_{DD} = 5V

All specifications T_{MIN} to T_{MAX}, AV_{DD} = +5V, DV_{DD} = +2.7V to 5.25V, f_{MOD} = 19.2kHz, PGA = 1, Buffer ON, f_{DATA} = 15Hz, and V_{REF} = +2.5V, unless otherwise specified.

PARAMETER	CONDITIONS	ADS1240 ADS1241			UNITS
		MIN	TYP	MAX	
ANALOG INPUT (A_{IN0} – A_{IN7}, A_{INCOM}) Analog Input Range	Buffer OFF Buffer ON	AGND – 0.1 AGND + 0.05		AV _{DD} + 0.1 AV _{DD} – 1.5	V V
Full-Scale Input Range	(In+) – (In–), See Block Diagram, RANGE = 0 RANGE = 1			±V _{REF} /PGA ±V _{REF} /(2 • PGA)	V V
Differential Input Impedance	Buffer OFF Buffer ON		5/PGA 5		MΩ GΩ
Bandwidth					
f _{DATA} = 3.75Hz	–3dB		1.65		Hz
f _{DATA} = 7.50Hz	–3dB		3.44		Hz
f _{DATA} = 15.00Hz	–3dB		14.6		Hz
Programmable Gain Amplifier	User-Selectable Gain Ranges	1		128	
Input Capacitance			9		pF
Input Leakage Current	Modulator OFF, T = 25°C		5		pA
Burnout Current Sources			2		μA
OFFSET DAC Offset DAC Range	RANGE = 0 RANGE = 1		±V _{REF} /(2 • PGA) ±V _{REF} /(4 • PGA)		V V
Offset Monotonicity		8			Bits
Offset DAC Gain Error			±10		%
Offset DAC Gain Error Drift			1		ppm/°C
SYSTEM PERFORMANCE Resolution	No Missing Codes End Point Fit	24		±0.0015	Bits % of FS
Integral Nonlinearity			7.5		ppm of FS
Offset Error ⁽¹⁾			0.02		ppm of FS/°C
Offset Drift ⁽¹⁾			0.005		%
Gain Error			0.5		ppm/°C
Gain Error Drift ⁽¹⁾					ppm/°C
Common-Mode Rejection	at DC f _{CM} = 60Hz, f _{DATA} = 15Hz f _{CM} = 50Hz, f _{DATA} = 15Hz	100	130 120		dB dB
Normal-Mode Rejection	f _{SIG} = 50Hz, f _{DATA} = 15Hz f _{SIG} = 60Hz, f _{DATA} = 15Hz		100 100		dB dB
Output Noise			See Typical Characteristics		
Power-Supply Rejection	at DC, dB = –20 log(ΔV _{OUT} /ΔV _{DD}) ⁽²⁾	80	95		dB
VOLTAGE REFERENCE INPUT V _{REF} Reference Input Range	V _{REF} ≡ (REF IN+) – (REF IN–), RANGE = 0 REF IN+, REF IN– RANGE = 1	0.1 0 0.1	2.5	2.6 AV _{DD} AV _{DD}	V V V
Common-Mode Rejection	at DC		120		dB
Common-Mode Rejection	f _{VREFCM} = 60Hz, f _{DATA} = 15Hz		120		dB
Bias Current ⁽³⁾	V _{REF} = 2.5V		1.3		μA
POWER-SUPPLY REQUIREMENTS Power-Supply Voltage	AV _{DD}	4.75		5.25	V
Analog Current	PDWN = 0, or SLEEP PGA = 1, Buffer OFF PGA = 128, Buffer OFF		1 120 400	250 675	nA μA μA
	PGA = 1, Buffer ON PGA = 128, Buffer ON		160 760	300 1275	μA μA
Digital Current	Normal Mode, DV _{DD} = 5V SLEEP Mode, DV _{DD} = 5V Read Data Continuous Mode, DV _{DD} = 5V PDWN		80 60 230 0.5	125	μA μA μA nA
Power Dissipation	PGA = 1, Buffer OFF, DV _{DD} = 5V		1.1	1.9	mW

NOTES: (1) Calibration can minimize these errors to the level of the noise.

(2) ΔV_{OUT} is a change in digital result.

(3) 12pF switched capacitor at f_{SAMP} clock frequency.

ELECTRICAL CHARACTERISTICS: $AV_{DD} = 3V$

All specifications $-40^{\circ}C$ to $+85^{\circ}C$, $AV_{DD} = +3V$, $DV_{DD} = +2.7V$ to $5.25V$, $f_{MOD} = 19.2kHz$, $PGA = 1$, Buffer ON, $f_{DATA} = 15Hz$, and $V_{REF} = +1.25V$, unless otherwise specified.

PARAMETER	CONDITIONS	ADS1240 ADS1241			UNITS
		MIN	TYP	MAX	
ANALOG INPUT ($A_{IN0} - A_{IN7}$, A_{INCOM}) Analog Input Range	Buffer OFF Buffer ON	AGND - 0.1 AGND + 0.05		$AV_{DD} + 0.1$ $AV_{DD} - 1.5$	V V
Full-Scale Input Voltage Range	(In+) - (In-) See Block Diagram, RANGE = 0 RANGE = 1			$\pm V_{REF}/PGA$ $\pm V_{REF}/(2 \cdot PGA)$	V V
Input Impedance Differential	Buffer OFF Buffer ON		5/PGA 5		M Ω G Ω
Bandwidth $f_{DATA} = 3.75Hz$	-3dB		1.65		Hz
$f_{DATA} = 7.50Hz$	-3dB		3.44		Hz
$f_{DATA} = 15.00Hz$	-3dB		14.6		Hz
Programmable Gain Amplifier Input Capacitance	User-Selectable Gain Ranges	1		128	pF
Input Leakage Current	Modulator OFF, T = 25°C		9		pA
Burnout Current Sources			5		pA
			2		μA
OFFSET DAC Offset DAC Range	RANGE = 0 RANGE = 1			$\pm V_{REF}/(2 \cdot PGA)$ $\pm V_{REF}/(4 \cdot PGA)$	V V
Offset DAC Monotonicity		8			Bits
Offset DAC Gain Error			± 10		%
Offset DAC Gain Error Drift			2		ppm/ $^{\circ}C$
SYSTEM PERFORMANCE Resolution	No Missing Codes End Point Fit	24		± 0.0015	Bits
Integral Nonlinearity					% of FS
Offset Error ⁽¹⁾			15		ppm of FS
Offset Drift ⁽¹⁾			0.04		ppm of FS/ $^{\circ}C$
Gain Error			0.01		%
Gain Error Drift ⁽¹⁾			1.0		ppm/ $^{\circ}C$
Common-Mode Rejection	at DC $f_{CM} = 60Hz$, $f_{DATA} = 15Hz$ $f_{CM} = 50Hz$, $f_{DATA} = 15Hz$	100	130 120		dB dB
Normal-Mode Rejection	$f_{SIG} = 50Hz$, $f_{DATA} = 15Hz$ $f_{SIG} = 60Hz$, $f_{DATA} = 15Hz$		100 100		dB dB
Output Noise			See Typical Characteristics		
Power-Supply Rejection	at DC, dB = $-20 \log(\Delta V_{OUT}/\Delta V_{DD})^{(2)}$	75	90		dB
VOLTAGE REFERENCE INPUT V_{REF} Reference Input Range	$V_{REF} \equiv (REF\ IN+) - (REF\ IN-)$, RANGE = 0 REF IN+, REF IN- RANGE = 1	0.1 0 0.1	1.25 2.5	1.30 AV_{DD} 2.6	V V V
Common-Mode Rejection	at DC		120		dB
Common-Mode Rejection	$f_{VREFCM} = 60Hz$, $f_{DATA} = 15Hz$		120		dB
Bias Current ⁽³⁾	$V_{REF} = 1.25$		0.65		μA
POWER-SUPPLY REQUIREMENTS Power-Supply Voltage	AV_{DD}	2.7		3.3	V
Analog Current	PDWN = 0, or SLEEP PGA = 1, Buffer OFF		1 107		nA μA
	PGA = 128, Buffer OFF		355	225	μA
	PGA = 1, Buffer ON		118	275	μA
	PGA = 128, Buffer ON		483	1225	μA
Digital Current	Normal Mode, $DV_{DD} = 3V$ SLEEP Mode, $DV_{DD} = 3V$		50 40	100	μA μA
	Read Data Continuous Mode, $DV_{DD} = 3V$		113		μA
	PDWN = 0		0.5		nA
Power Dissipation	PGA = 1, Buffer OFF, $DV_{DD} = 3V$		0.6	1.2	mW

NOTES: (1) Calibration can minimize these errors to the level of the noise.

(2) ΔV_{OUT} is a change in digital result.

(3) 12pF switched capacitor at f_{SAMP} clock frequency.

PIN CONFIGURATION (ADS1240)

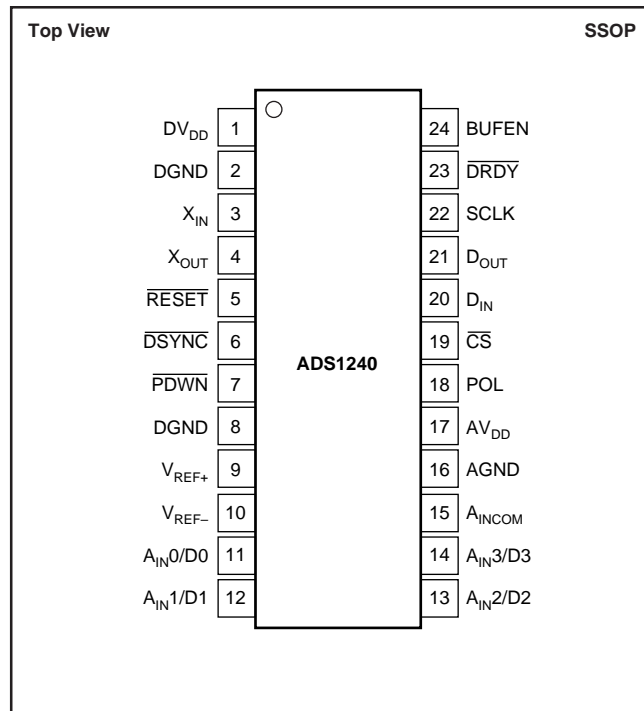

PIN CONFIGURATION (ADS1241)

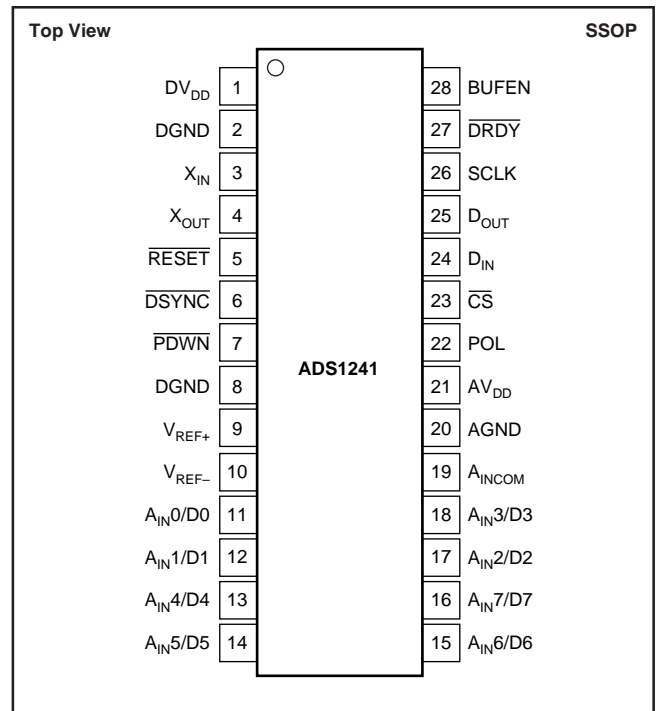

PIN DESCRIPTIONS (ADS1240)

PIN NUMBER	NAME	DESCRIPTION
1	DV _{DD}	Digital Power Supply
2	DGND	Digital Ground
3	X _{IN}	Clock Input
4	X _{OUT}	Clock Output, used with external crystals.
5	RESET	Active LOW, resets the entire device.
6	DSYNC	Active LOW, Synchronization Control
7	PDWN	Active LOW, Power Down. The power down function shuts down the analog and digital circuits.
8	DGND	Digital Ground
9	V _{REF+}	Positive Differential Reference Input
10	V _{REF-}	Negative Differential Reference Input
11	A _{IN} 0/D0	Analog Input 0 / Data I/O 0
12	A _{IN} 1/D1	Analog Input 1 / Data I/O 1
13	A _{IN} 2/D2	Analog Input 2 / Data I/O 2
14	A _{IN} 3/D3	Analog Input 3 / Data I/O 3
15	A _{IN} COM	Analog Input Common, connect to AGND if unused.
16	AGND	Analog Ground
17	AV _{DD}	Analog Power Supply
18	POL	Serial Clock Polarity
19	CS	Active LOW, Chip Select
20	D _{IN}	Serial Data Input, Schmitt Trigger
21	D _{OUT}	Serial Data Output
22	SCLK	Serial Clock, Schmitt Trigger
23	DRDY	Active LOW, Data Ready
24	BUFEN	Buffer Enable

PIN DESCRIPTIONS (ADS1241)

PIN NUMBER	NAME	DESCRIPTION
1	DV _{DD}	Digital Power Supply
2	DGND	Digital Ground
3	X _{IN}	Clock Input
4	X _{OUT}	Clock Output, used with external crystals.
5	RESET	Active LOW, resets the entire device.
6	DSYNC	Active LOW, Synchronization Control
7	PDWN	Active LOW, Power Down. The power down function shuts down the analog and digital circuits.
8	DGND	Digital Ground
9	V _{REF+}	Positive Differential Reference Input
10	V _{REF-}	Negative Differential Reference Input
11	A _{IN} 0/D0	Analog Input 0 / Data I/O 0
12	A _{IN} 1/D1	Analog Input 1 / Data I/O 1
13	A _{IN} 4/D4	Analog Input 4 / Data I/O 4
14	A _{IN} 5/D5	Analog Input 5 / Data I/O 5
15	A _{IN} 6/D6	Analog Input 6 / Data I/O 6
16	A _{IN} 7/D7	Analog Input 7 / Data I/O 7
17	A _{IN} 2/D2	Analog Input 2 / Data I/O 2
18	A _{IN} 3/D3	Analog Input 3 / Data I/O 3
19	A _{IN} COM	Analog Input Common, connect to AGND if unused.
20	AGND	Analog Ground
21	AV _{DD}	Analog Power Supply
22	POL	Serial Clock Polarity
23	CS	Active LOW, Chip Select
24	D _{IN}	Serial Data Input, Schmitt Trigger
25	D _{OUT}	Serial Data Output
26	SCLK	Serial Clock, Schmitt Trigger
27	DRDY	Active LOW, Data Ready
28	BUFEN	Buffer Enable

TIMING DIAGRAMS

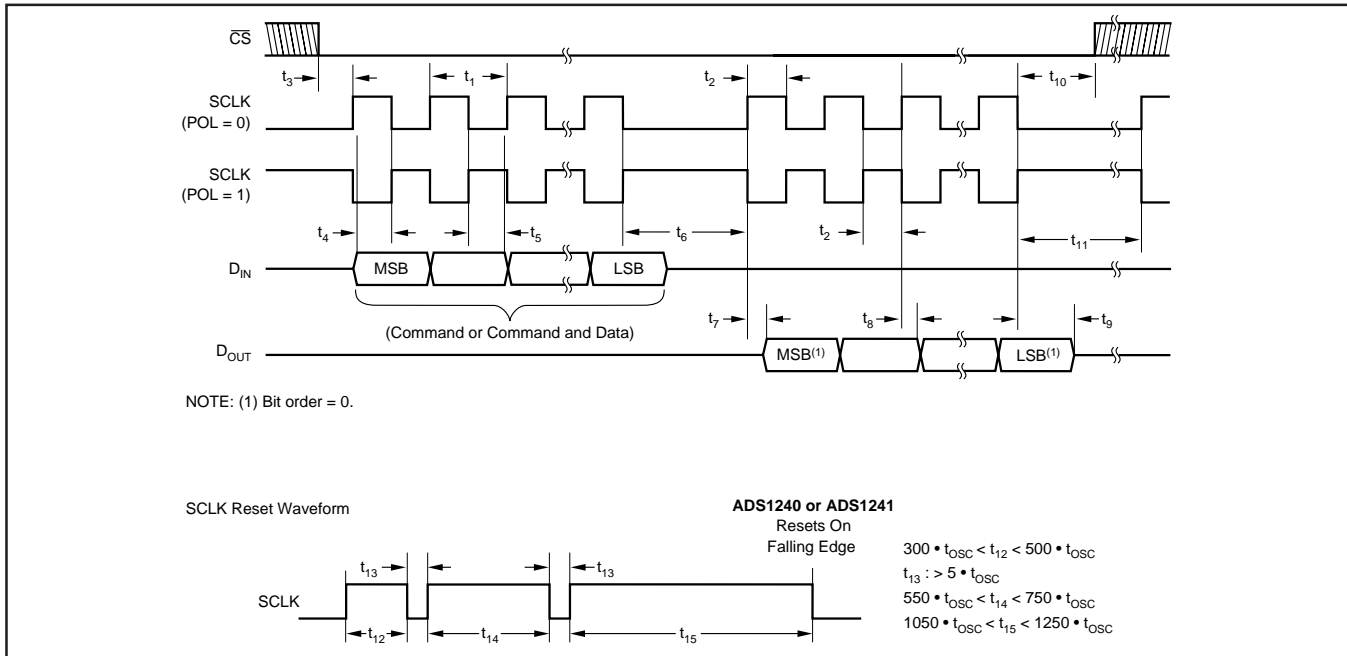

DIAGRAM 1.

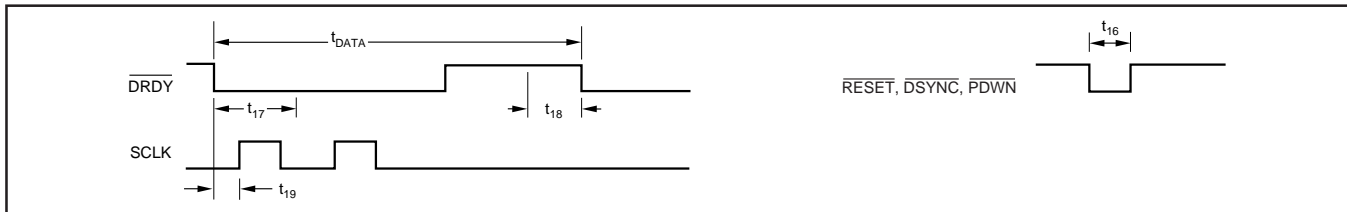

DIAGRAM 2.

TIMING CHARACTERISTICS TABLE

SPEC	DESCRIPTION	MIN	MAX	UNITS
t_1	SCLK Period	4	3	t_{osc} Periods DRDY Periods
t_2	SCLK Pulse Width, HIGH and LOW	200		ns
t_3	\overline{CS} low to first SCLK Edge; Setup Time ⁽²⁾	0		ns
t_4	D_{IN} Valid to SCLK Edge; Setup Time	50		ns
t_5	Valid D_{IN} to SCLK Edge; Hold Time	50		ns
t_6	Delay between last SCLK edge for D_{IN} and first SCLK edge for D_{OUT} : RDATA, RDATA, RREG, WREG	50		t_{osc} Periods
$t_7^{(1)}$	SCLK Edge to Valid New D_{OUT}		50	ns
$t_8^{(1)}$	SCLK Edge to D_{OUT} , Hold Time	0		ns
t_9	Last SCLK Edge to D_{OUT} Tri-State NOTE: D_{OUT} goes tri-state immediately when \overline{CS} goes HIGH.	6	10	t_{osc} Periods
t_{10}	\overline{CS} LOW time after final SCLK edge. Read from the device Write to the device	0 8		t_{osc} Periods t_{osc} Periods
t_{11}	Final SCLK edge of one command until first edge SCLK of next command: RREG, WREG, DSYNC, SLEEP, RDATA, RDATA, STOPC SELFGCAL, SELFOCAL, SYSOCAL, SYSGCAL SELCAL RESET (also SCLK Reset or \overline{RESET} Pin)	4 2 4 16		t_{osc} Periods DRDY Periods DRDY Periods t_{osc} Periods
t_{16}	Pulse Width	4		t_{osc} Periods
t_{17}	Allowed analog input change for next valid conversion.		5000	t_{osc} Periods
t_{18}	DOR update, DOR data not valid.	4		t_{osc} Periods
t_{19}	First SCLK after DRDY goes LOW: RDATA Mode Any other mode	10 0		t_{osc} Periods t_{osc} Periods

NOTES: (1) Load = 20pF || 10kΩ to DGND.
(2) \overline{CS} may be tied LOW.

TYPICAL CHARACTERISTICS

All specifications $AV_{DD} = +5V$, $DV_{DD} = +5V$, $f_{OSC} = 2.4576MHz$, $PGA = 1$, $f_{DATA} = 15Hz$, and $V_{REF} \equiv (REF IN+) - (REF IN-) = +2.5V$, unless otherwise specified.

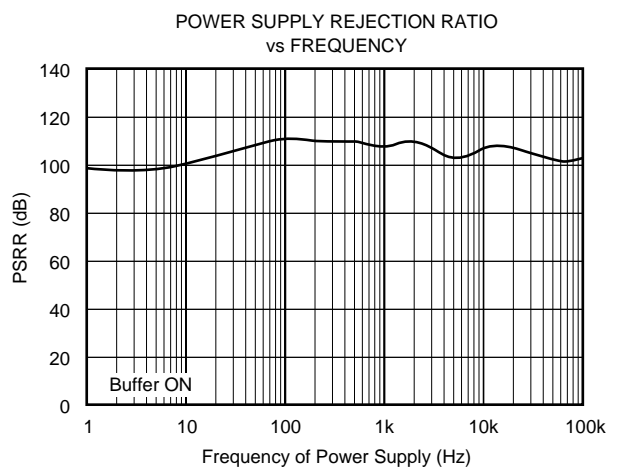
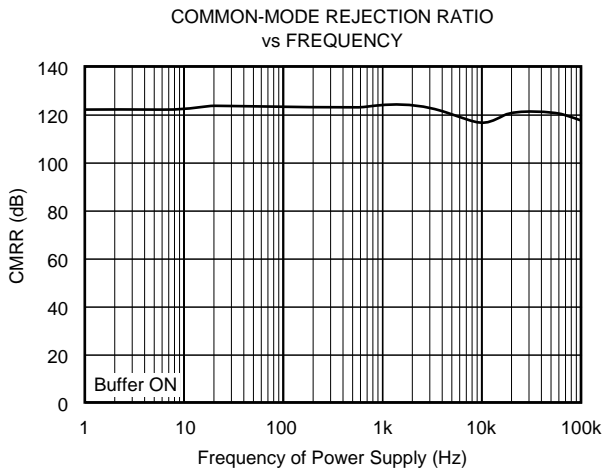
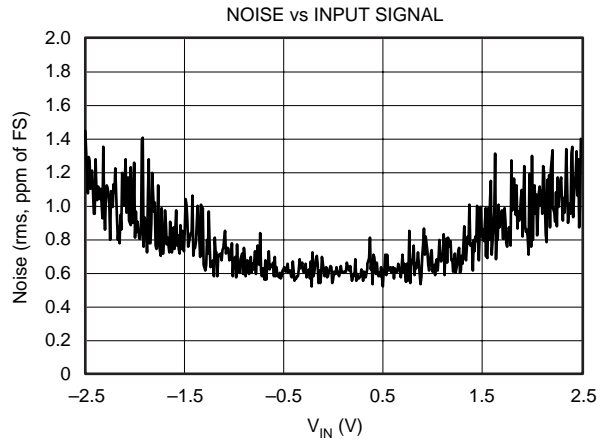
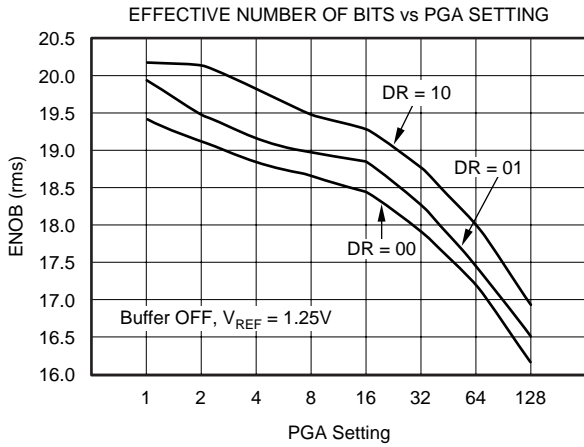
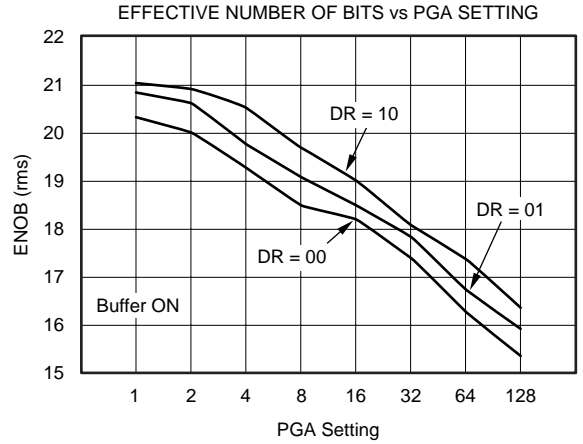
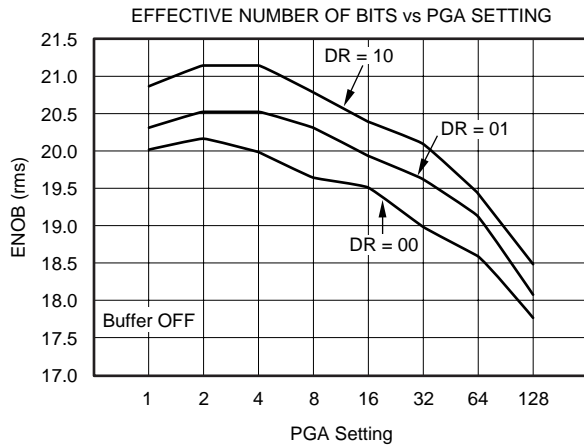

TYPICAL CHARACTERISTICS (Cont.)

All specifications $AV_{DD} = +5V$, $DV_{DD} = +5V$, $f_{OSC} = 2.4576MHz$, $PGA = 1$, $f_{DATA} = 15Hz$, and $V_{REF} \equiv (REF IN+) - (REF IN-) = +2.5V$, unless otherwise specified.

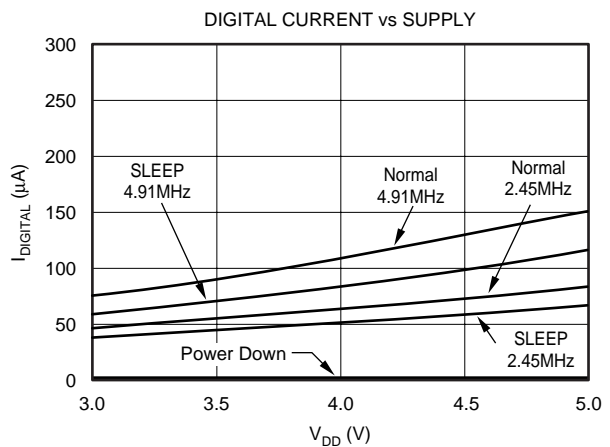
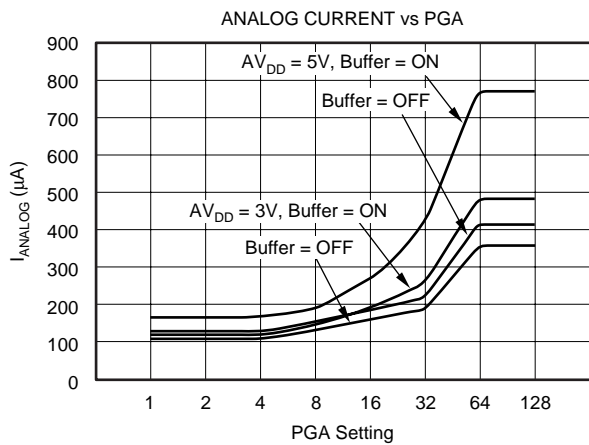
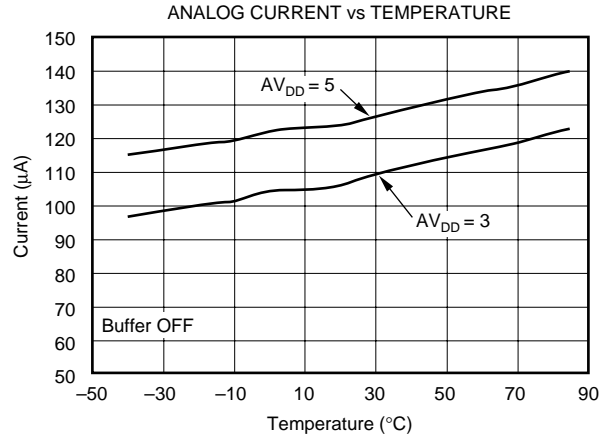
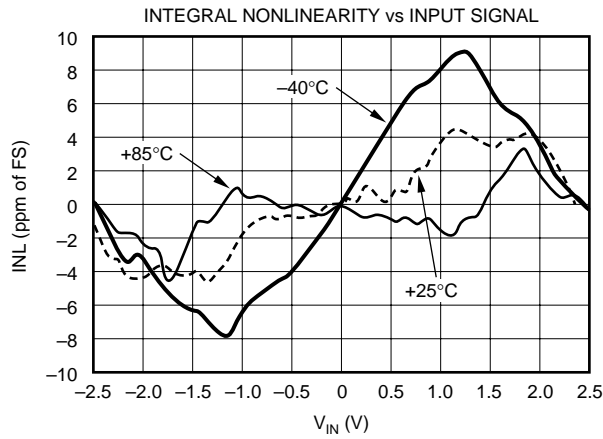
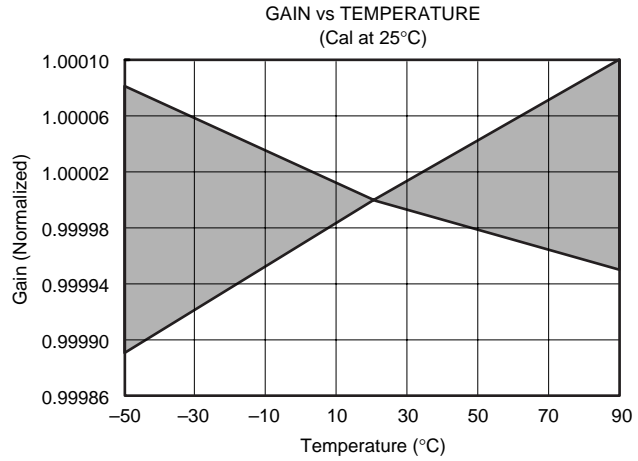
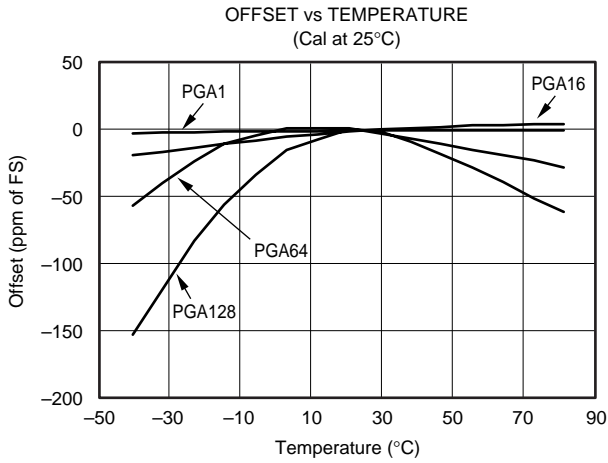

TYPICAL CHARACTERISTICS (Cont.)

All specifications $AV_{DD} = +5V$, $DV_{DD} = +5V$, $f_{OSC} = 2.4576MHz$, $PGA = 1$, $f_{DATA} = 15Hz$, and $V_{REF} \equiv (REF\ IN+) - (REF\ IN-) = +2.5V$, unless otherwise specified.

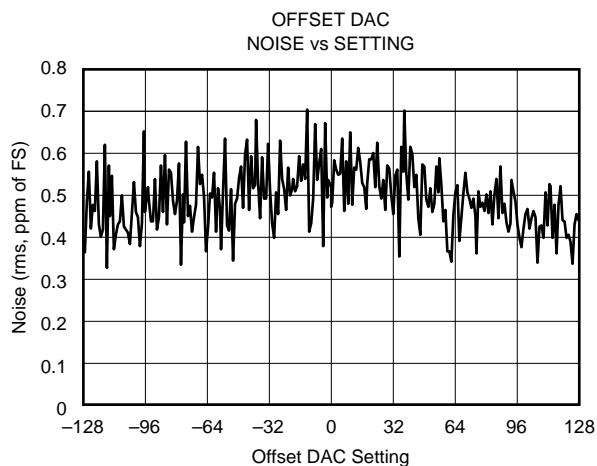
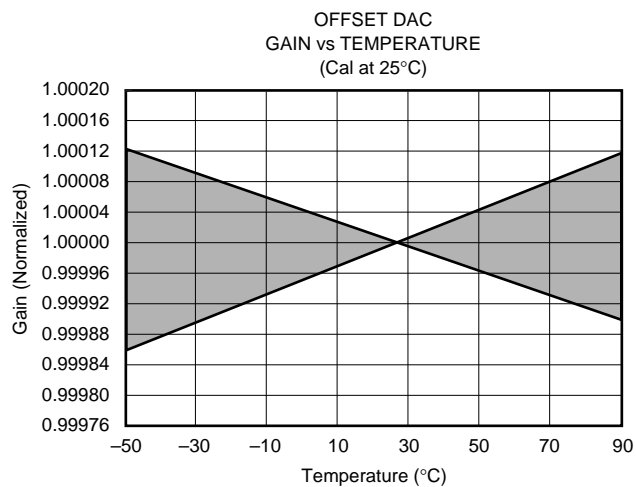
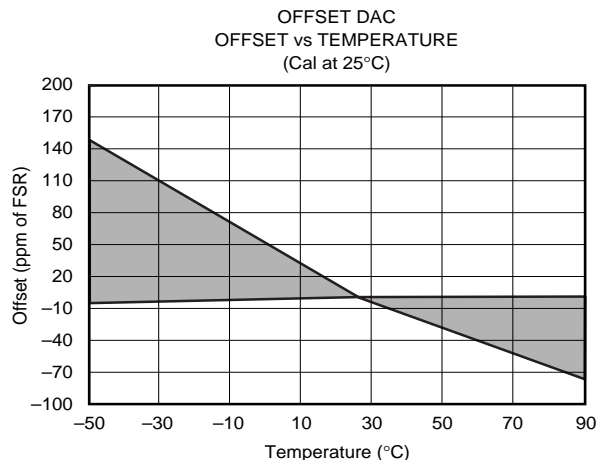
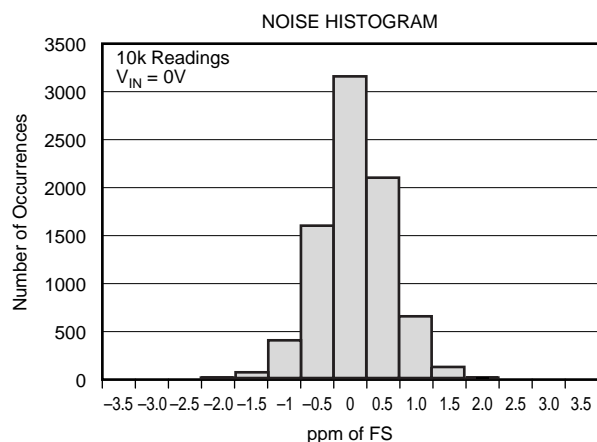

OVERVIEW

INPUT MULTIPLEXER

The input multiplexer provides for any combination of differential inputs to be selected on any of the input channels, as shown in Figure 1. For example, if A_{IN0} is selected as the positive differential input channel, any other channel can be selected as the negative terminal for the differential input

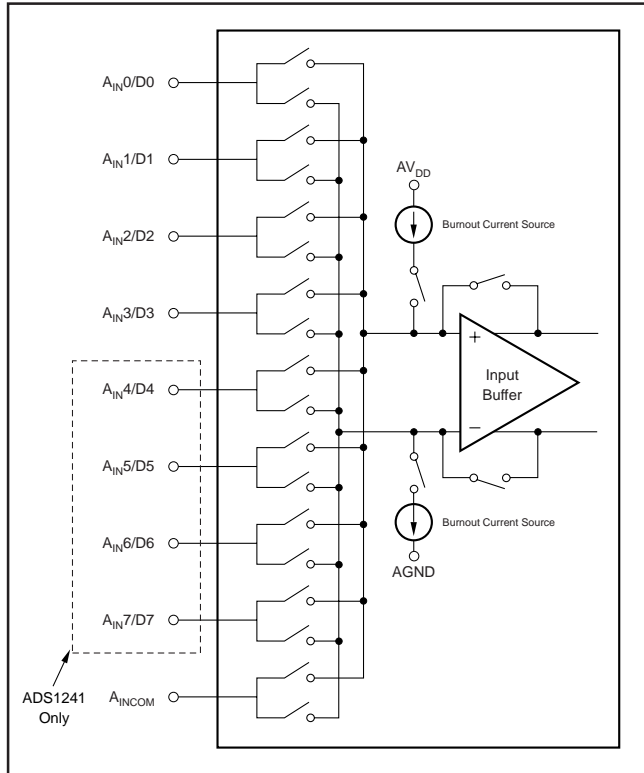

FIGURE 1. Input Multiplexer Configuration.

channel. With this method, it is possible to have up to eight single-ended input channels or four independent differential input channels for the ADS1241, and four single-ended input channels or two independent differential input channels for the ADS1240. Note that A_{INCOM} can be treated as an input channel.

The ADS1240 and ADS1241 feature a single-cycle settling digital filter that provides valid data on the first conversion after a new channel selection. In order to minimize the settling error, synchronize MUX changes to the conversion beginning, which is indicated by the falling edge of \overline{DRDY} . In other words, issuing a MUX change through the WREG command immediately after \overline{DRDY} goes LOW minimizes the settling error. Increasing the time between the conversion beginning (\overline{DRDY} goes LOW) and the MUX change command (t_{DELAY}) results in a settling error in the conversion data, as shown in Figure 2.

BURNOUT CURRENT SOURCES

The Burnout Current Sources can be used to detect sensor short-circuit or open-circuit conditions. Setting the Burnout Current Sources (BOCS) bit in the SETUP register activates two $2\mu A$ current sources called burnout current sources. One of the current sources is connected to the converter's negative input and the other is connected to the converter's positive input.

Figure 3 shows the situation for an open-circuit sensor. This is a potential failure mode for many kinds of remotely connected sensors. The current source on the positive input acts as a pull-up, causing the positive input to go to the positive analog supply, and the current source on the negative input acts as a pull-down, causing the negative input to go to ground. The ADS1240/41 therefore outputs full-scale (7FFFF Hex).

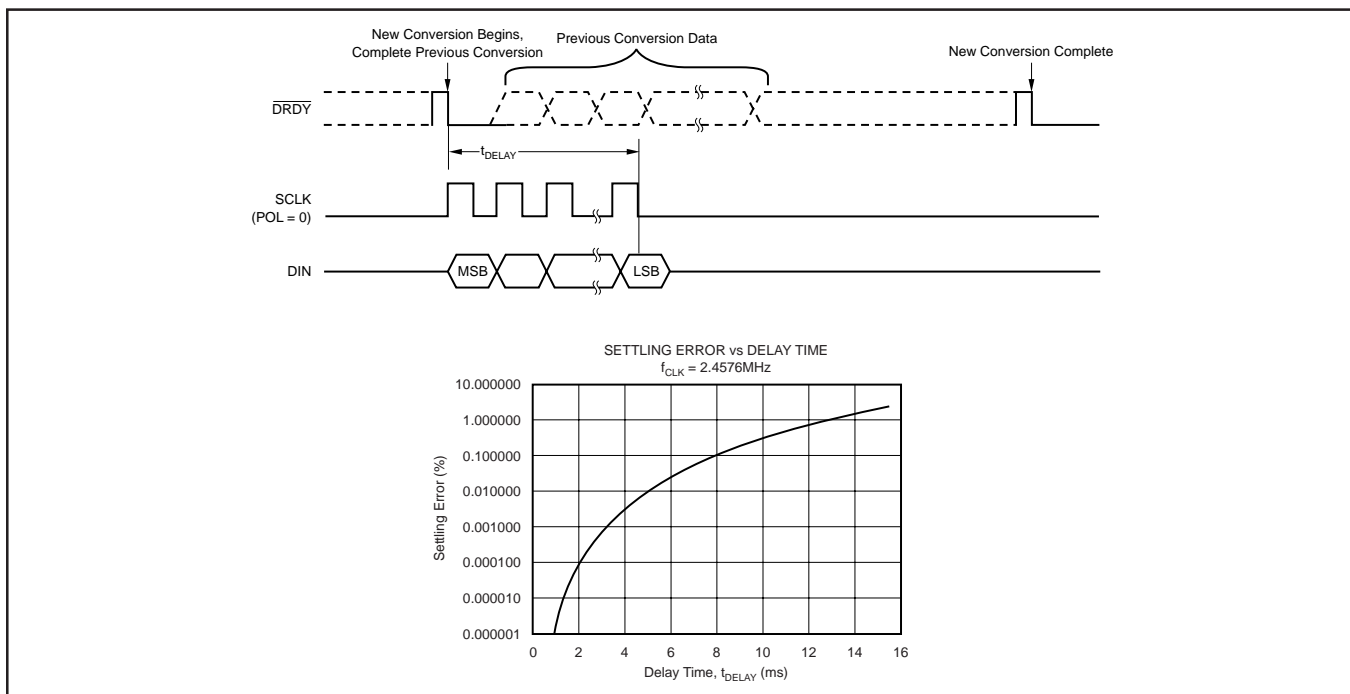

FIGURE 2. Input Multiplexer Configuration.

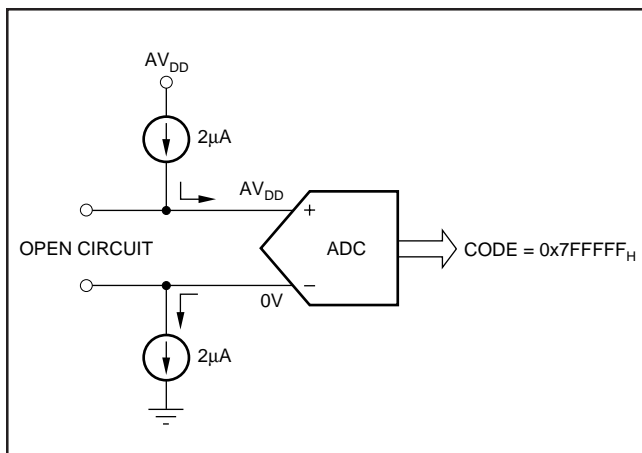

FIGURE 3. Burnout detection while sensor is open-circuited.

Figure 4 shows a short-circuited sensor. Since the inputs are shorted and at the same potential, the ADS1240/41 signal outputs are approximately zero. (Note that the code for shorted inputs is not exactly zero due to internal series resistance, low-level noise and other error sources.)

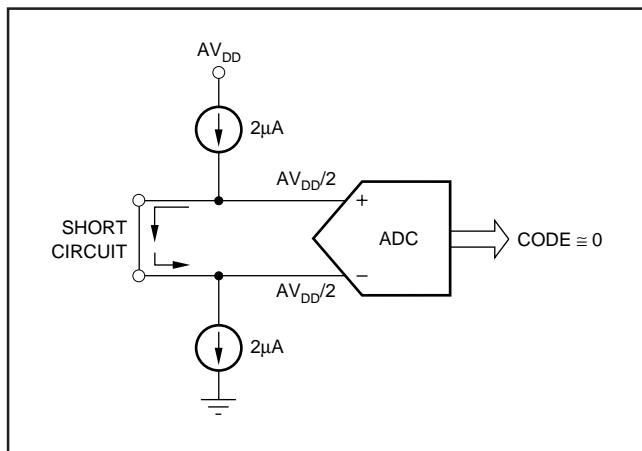

FIGURE 4. Burnout detection while sensor is short-circuited.

INPUT BUFFER

The input impedance of the ADS1240/41 without the buffer enabled is approximately $5M\Omega/\text{PGA}$. For systems requiring very high input impedance, the ADS1240/41 provides a chopper-stabilized differential FET-input voltage buffer. When activated, the buffer raises the ADS1240/41 input impedance to approximately $5G\Omega$.

The buffer's input range is approximately 50mV to $AV_{DD} - 1.5V$. The buffer's linearity will degrade beyond this range. Differential signals should be adjusted so that both signals are within the buffer's input range.

The buffer can be enabled using the BUFEN pin or the BUFEN bit in the ACR register. The buffer is on when the BUFEN pin is high and the BUFEN bit is set to one. If the BUFEN pin is low, the buffer is disabled. If the BUFEN bit is set to zero, the buffer is also disabled.

The buffer draws additional current when activated. The current required by the buffer depends on the PGA setting. When the PGA is set to 1, the buffer uses approximately $50\mu A$; when the PGA is set to 128, the buffer uses approximately $500\mu A$.

PGA

The Programmable Gain Amplifier (PGA) can be set to gains of 1, 2, 4, 8, 16, 32, 64, or 128. Using the PGA can improve the effective resolution of the A/D converter. For instance, with a PGA of 1 on a 5V full-scale signal, the A/D converter can resolve down to $1\mu V$. With a PGA of 128 and a full-scale signal of 39mV, the A/D converter can resolve down to $75nV$. AV_{DD} current increases with PGA settings higher than 4.

OFFSET DAC

The input to the PGA can be shifted by half the full-scale input range of the PGA using the Offset DAC (ODAC) register. The ODAC register is an 8-bit value; the MSB is the sign and the seven LSBs provide the magnitude of the offset. Using the offset DAC does not reduce the performance of the A/D converter. For more details on the ODAC, please refer to TI application report SBAA077.

MODULATOR

The modulator is a single-loop second-order system. The modulator runs at a clock speed (f_{MOD}) that is derived from the external clock (f_{OSC}). The frequency division is determined by the SPEED bit in the SETUP register, as shown in Table I.

f_{OSC}	SPEED BIT	f_{MOD}	DR BITS			1st NOTCH FREQ.
			00	01	10	
2.4576MHz	0	19,200Hz	15Hz	7.5Hz	3.75Hz	50/60Hz
	1	9,600Hz	7.5Hz	3.75Hz	1.875Hz	25/30Hz
4.9152MHz	0	38,400Hz	30Hz	15Hz	7.5Hz	100/120Hz
	1	19,200Hz	15Hz	7.5Hz	3.75Hz	50/60Hz

TABLE I. Output Configuration.

CALIBRATION

The offset and gain errors can be minimized with calibration. The ADS1240 and ADS1241 support both self and system calibration.

Self-calibration of the ADS1240 and ADS1241 corrects internal offset and gain errors and is handled by three commands: SELFCAL, SELFGAL, and SLEFOCAL. The SELFCAL command performs both an offset and gain calibration. SELFGAL performs a gain calibration and SLEFOCAL performs an offset calibration, each of which takes two t_{DATA} periods to complete. During self-calibration, the ADC inputs are disconnected internally from the input pins. The PGA must be set to 1 prior to issuing a SELFCAL or SELFGAL command. Any PGA is allowed when issuing a SLEFOCAL command. For example, if using $\text{PGA} = 64$, first set $\text{PGA} = 1$ and issue

SELFGCAL. Afterwards set PGA = 64 and issue SELFOCAL. For operation with a reference voltage greater than ($AV_{DD} - 1.5$) volts, the buffer must also be turned off during gain self-calibration to avoid exceeding the buffer input range.

System calibration corrects both internal and external offset and gain errors. While performing system calibration, the appropriate signal must be applied to the inputs. The system offset calibration command (SYSOCAL) requires a zero input differential signal (see Table IV, page 18). It then computes the offset that nullifies the offset in the system. The system gain calibration command (SYSGCAL) requires a positive full-scale input signal. It then computes a value to nullify the gain error in the system. Each of these calibrations takes two t_{DATA} periods to complete. System gain calibration is recommended for the best gain calibration at higher PGAs.

Calibration should be performed after power on, a change in temperature, or a change of the PGA. The RANGE bit (ACR bit 2) must be zero during calibration.

Calibration removes the effects of the ODAC; therefore, disable the ODAC during calibration, and enable again after calibration is complete.

At the completion of calibration, the \overline{DRDY} signal goes low, indicating the calibration is finished. The first data after calibration should be discarded since it may be corrupt from calibration data remaining in the filter. The second data is always valid.

EXTERNAL VOLTAGE REFERENCE

The ADS1240 and ADS1241 require an external voltage reference. The selection for the voltage reference value is made through the ACR register.

The external voltage reference is differential and is represented by the voltage difference between the pins: $+V_{REF}$ and $-V_{REF}$. The absolute voltage on either pin, $+V_{REF}$ or $-V_{REF}$, can range from AGND to AV_{DD} . However, the following limitations apply:

For $AV_{DD} = 5.0V$ and RANGE = 0 in the ACR, the differential V_{REF} must not exceed 2.5V.

For $AV_{DD} = 5.0V$ and RANGE = 1 in the ACR, the differential V_{REF} must not exceed 5V.

For $AV_{DD} = 3.0V$ and RANGE = 0 in the ACR, the differential V_{REF} must not exceed 1.25V.

For $AV_{DD} = 3.0V$ and RANGE = 1 in the ACR, the differential V_{REF} must not exceed 2.5V.

CLOCK GENERATOR

The clock source for the ADS1240 and ADS1241 can be provided from a crystal, oscillator, or external clock. When the clock source is a crystal, external capacitors must be provided to ensure start-up and stable clock frequency. This is shown in both Figure 5 and Table II. X_{OUT} is only for use with external crystals and it should not be used as a clock driver for external circuitry.

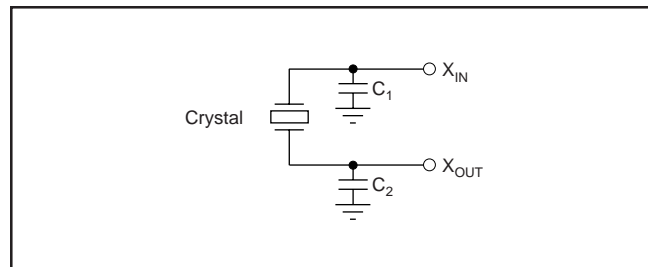

FIGURE 5. Crystal Connection.

CLOCK SOURCE	FREQUENCY	C ₁	C ₂	PART NUMBER
Crystal	2.4576	0-20pF	0-20pF	ECS, ECSD 2.45 - 32
Crystal	4.9152	0-20pF	0-20pF	ECS, ECSL 4.91
Crystal	4.9152	0-20pF	0-20pF	ECS, ECSD 4.91
Crystal	4.9152	0-20pF	0-20pF	CTS, MP 042 4M9182

TABLE II. Recommended Crystals.

DIGITAL FILTER

The ADS1240 and ADS1241 have a 1279 tap linear phase Finite Impulse Response (FIR) digital filter that a user can configure for various output data rates. When a 2.4576MHz crystal is used, the device can be programmed for an output data rate of 15Hz, 7.5Hz, or 3.75Hz. Under these conditions, the digital filter rejects both 50Hz and 60Hz interference. Figure 6 shows the digital filter frequency response for data output rates of 15Hz, 7.5Hz, and 3.75Hz.

If a different data output rate is desired, a different crystal frequency can be used. However, the rejection frequencies shift accordingly. For example, a 3.6864MHz master clock with the default register condition has:

$$(3.6864\text{MHz}/2.4576\text{MHz}) \cdot 15\text{Hz} = 22.5\text{Hz data output rate}$$

and the first and second notch is:

$$1.5 \cdot (50\text{Hz and } 60\text{Hz}) = 75\text{Hz and } 90\text{Hz}$$

DATA I/O INTERFACE

The ADS1240 has four pins and the ADS1241 has eight pins that serve a dual purpose as both analog inputs and data I/O. These pins are powered from AV_{DD} and are configured through the IOCON, DIR, and DIO registers. These pins can be individually configured as either analog inputs or data I/O. See Figure 7 (page 14) for the equivalent schematic of an Analog/Data I/O pin.

The IOCON register defines the pin as either an analog input or data I/O. The power-up state is an analog input. If the pin is configured as an analog input in the IOCON register, the DIR and DIO registers have no effect on the state of the pin.

If the pin is configured as data I/O in the IOCON register, then DIR and DIO are used to control the state of the pin. The DIR register controls the direction of the data pin, either as an input or output. If the pin is configured as an input in the DIR register, then the corresponding DIO register bit reflects the state of the pin. Make sure the pin is driven to a

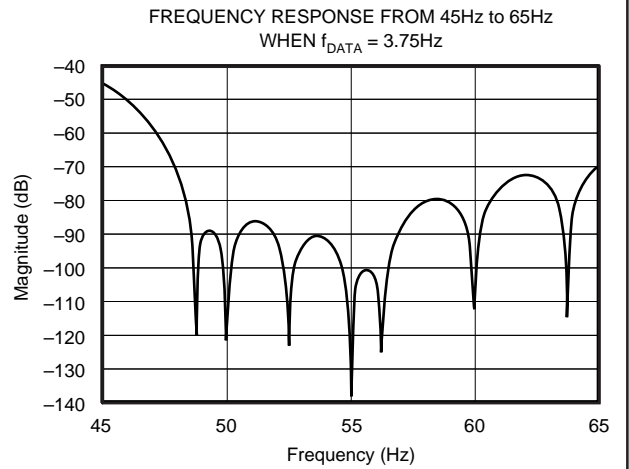
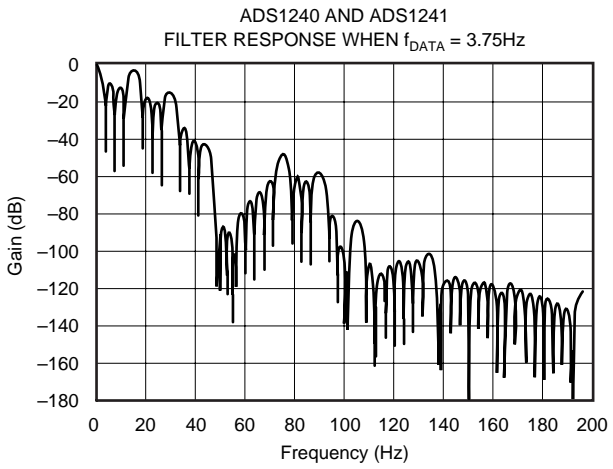
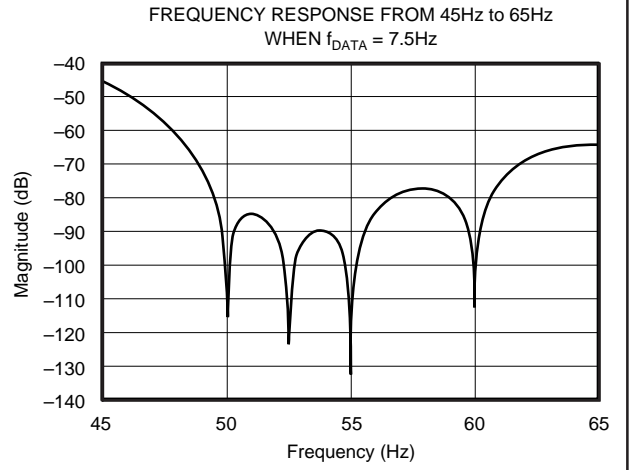
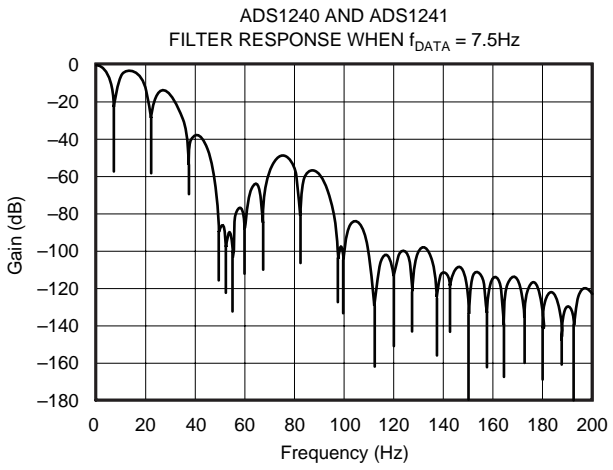
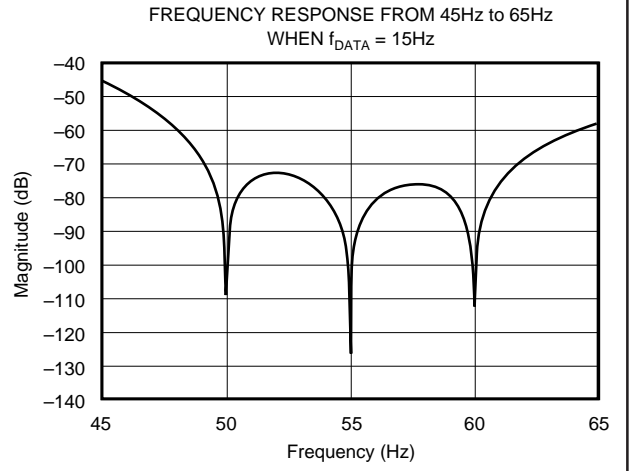
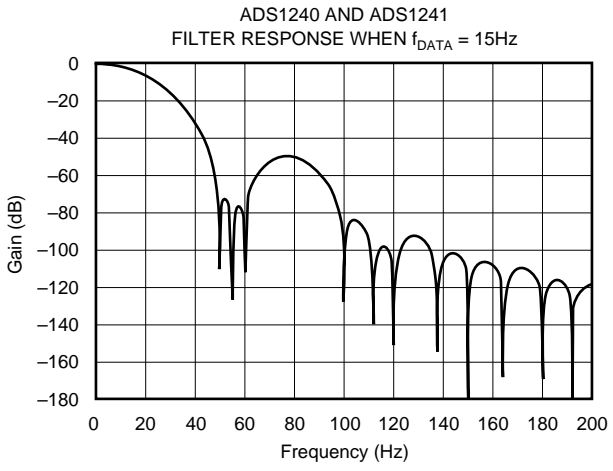

$f_{OSC} = 2.4576\text{MHz}$, SPEED = 0 or $f_{OSC} = 4.9152\text{MHz}$, SPEED = 1

DATA OUTPUT RATE	-3dB BANDWIDTH	ATTENUATION			
		$f_{IN} = 50 \pm 0.3\text{Hz}$	$f_{IN} = 60 \pm 0.3\text{Hz}$	$f_{IN} = 50 \pm 1\text{Hz}$	$f_{IN} = 60 \pm 1\text{Hz}$
15Hz	14.6Hz	-80.8dB	-87.3dB	-68.5dB	-76.1dB
7.5Hz	3.44Hz	-85.9dB	-87.4dB	-71.5dB	-76.2dB
3.75Hz	1.65Hz	-93.8dB	-88.6dB	-86.8dB	-77.3dB

FIGURE 6. Filter Frequency Responses.

logic one or zero when configured as an input to prevent excess current dissipation. If the pin is configured as an output in the DIR register, then the corresponding DIO register bit value determines the state of the output pin (0 = AGND, 1 = AV_{DD}).

It is still possible to perform A/D conversions on a pin configured as data I/O. This may be useful as a test mode, where the data I/O pin is driven and an A/D conversion is done on the pin.

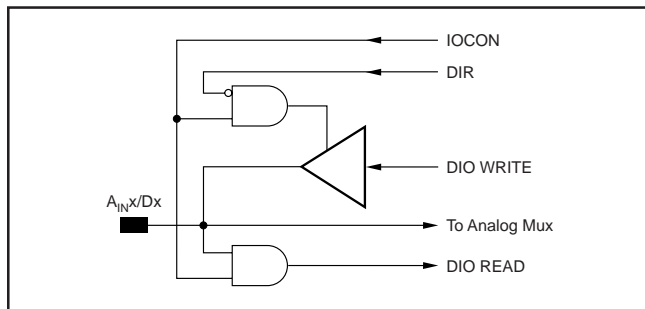

FIGURE 7. Analog/Data Interface Pin.

SERIAL PERIPHERAL INTERFACE

The Serial Peripheral Interface (SPI) allows a controller to communicate synchronously with the ADS1240 and ADS1241. The ADS1240 and ADS1241 operate in slave-only mode. The serial interface is a standard four-wire SPI (\overline{CS} , SCLK, D_{IN} and D_{OUT}) interface that supports both serial clock polarities (POL pin).

Chip Select (\overline{CS})

The chip select (\overline{CS}) input must be externally asserted before communicating with the ADS1240 or ADS1241. \overline{CS} must stay LOW for the duration of the communication. Whenever \overline{CS} goes HIGH, the serial interface is reset. \overline{CS} may be hard-wired LOW.

Serial Clock (SCLK)

The serial clock (SCLK) features a Schmitt-triggered input and is used to clock D_{IN} and D_{OUT} data. Make sure to have a clean SCLK to prevent accidental double-shifting of the data. If SCLK is not toggled within 3 \overline{DRDY} pulses, the serial interface resets on the next SCLK pulse and starts a new communication cycle. A special pattern on SCLK resets the entire chip; see the RESET section for additional information.

Clock Polarity (POL)

The clock polarity input (POL) controls the polarity of SCLK. When POL is LOW, data is clocked on the falling edge of SCLK and SCLK should be idled LOW. Likewise, when POL is HIGH, the data is clocked on the rising edge of SCLK and SCLK should be idled HIGH.

Data Input (D_{IN}) and Data Output (D_{OUT})

The data input (D_{IN}) and data output (D_{OUT}) receive and send data from the ADS1240 and ADS1241. D_{OUT} is high impedance when not in use to allow D_{IN} and D_{OUT} to be connected together and driven by a bidirectional bus. Note: the Read

Data Continuous Mode (RDATA_C) command should not be issued when D_{IN} and D_{OUT} are connected. While in RDATA_C mode, D_{IN} looks for the STOPC or RESET command. If either of these 8-bit bytes appear on D_{OUT} (which is connected to D_{IN}), the RDATA_C mode ends.

DATA READY \overline{DRDY} PIN

The \overline{DRDY} line is used as a status signal to indicate when data is ready to be read from the internal data register. \overline{DRDY} goes LOW when a new data word is available in the DOR register. It is reset HIGH when a read operation from the data register is complete. It also goes HIGH prior to the updating of the output register to indicate when not to read from the device to ensure that a data read is not attempted while the register is being updated.

The status of \overline{DRDY} can also be obtained by interrogating bit 7 of the ACR register (address 2_H). The serial interface can operate in 3-wire mode by tying the \overline{CS} input LOW. In this case, the SCLK, D_{IN}, and D_{OUT} lines are used to communicate with the ADS1240 and ADS1241. This scheme is suitable for interfacing to microcontrollers. If \overline{CS} is required as a decoding signal, it can be generated from a port bit of the microcontroller.

DSYNC OPERATION

Synchronization can be achieved either through the \overline{DSYNC} pin or the DSYNC command. When the \overline{DSYNC} pin is used, the digital circuitry is reset on the falling edge of \overline{DSYNC} . While \overline{DSYNC} is LOW, the serial interface is deactivated. Reset is released when \overline{DSYNC} is taken HIGH. Synchronization occurs on the next rising edge of the system clock after \overline{DSYNC} is taken HIGH.

When the DSYNC command is sent, the digital filter is reset on the edge of the last SCLK of the DSYNC command. The modulator is held in RESET until the next edge of SCLK is detected. Synchronization occurs on the next rising edge of the system clock after the first SCLK following the DSYNC command.

POWER-UP—SUPPLY VOLTAGE RAMP RATE

The power-on reset circuitry was designed to accommodate digital supply ramp rates as slow as 1V/10ms. To ensure proper operation, the power supply should ramp monotonically.

RESET

The user can reset the registers to their default values in three different ways: by asserting the RESET pin; by issuing the RESET command; or by applying a special waveform on the SCLK (the *SCLK Reset Waveform*, as shown in the Timing Diagram). Note: if both POL and SCLK pins are held high, applying the SCLK Reset Waveform to the \overline{CS} pin also resets the part.

ADS1240 AND ADS1241 REGISTER

The operation of the device is set up through individual registers. Collectively, the registers contain all the informa-

tion needed to configure the part, such as data format, multiplexer settings, calibration settings, data rate, etc. The set of the 16 registers are shown in Table III.

ADDRESS	REGISTER	BIT 7	BIT 6	BIT 5	BIT 4	BIT 3	BIT 2	BIT 1	BIT 0
00 _H	SETUP	ID	ID	ID	ID	BOCS	PGA2	PGA1	PGA0
01 _H	MUX	PSEL3	PSEL2	PSEL1	PSEL0	NSEL3	NSEL2	NSEL1	NSEL0
02 _H	ACR	DRDY	U/B	SPEED	BUFEN	BIT ORDER	RANGE	DR1	DR0
03 _H	ODAC	SIGN	OSET6	OSET5	OSET4	OSET3	OSET2	OSET1	OSET0
04 _H	DIO	DIO_7	DIO_6	DIO_5	DIO_4	DIO_3	DIO_2	DIO_1	DIO_0
05 _H	DIR	DIR_7	DIR_6	DIR_5	DIR_4	DIR_3	DIR_2	DIR_1	DIR_0
06 _H	IOCON	IO7	IO6	IO5	IO4	IO3	IO2	IO1	IO0
07 _H	OCR0	OCR07	OCR06	OCR05	OCR04	OCR03	OCR02	OCR01	OCR00
08 _H	OCR1	OCR15	OCR14	OCR13	OCR12	OCR11	OCR10	OCR09	OCR08
09 _H	OCR2	OCR23	OCR22	OCR21	OCR20	OCR19	OCR18	OCR17	OCR16
0A _H	FSR0	FSR07	FSR06	FSR05	FSR04	FSR03	FSR02	FSR01	FSR00
0B _H	FSR1	FSR15	FSR14	FSR13	FSR12	FSR11	FSR10	FSR09	FSR08
0C _H	FSR2	FSR23	FSR22	FSR21	FSR20	FSR19	FSR18	FSR17	FSR16
0D _H	DOR2	DOR23	DOR22	DOR21	DOR20	DOR19	DOR18	DOR17	DOR16
0E _H	DOR1	DOR15	DOR14	DOR13	DOR12	DOR11	DOR10	DOR09	DOR08
0F _H	DOR0	DOR07	DOR16	FSR21	DOR04	DOR03	DOR02	DOR01	DOR00

TABLE III. Registers.

DETAILED REGISTER DEFINITIONS

SETUP (Address 00_H) Setup Register

Reset Value = iii0000

bit 7	bit 6	bit 5	bit 4	bit 3	bit 2	bit 1	bit 0
ID	ID	ID	ID	BOCS	PGA2	PGA1	PGA0

bit 7-4 Factory Programmed Bits

bit 3 BOCS: Burnout Current Source
0 = Disabled (default)
1 = Enabled

bit 2-0 PGA2: PGA1: PGA0: Programmable Gain Amplifier Gain Selection
000 = 1 (default)
001 = 2
010 = 4
011 = 8
100 = 16
101 = 32
110 = 64
111 = 128

MUX (Address 01_H) Multiplexer Control Register

Reset Value = 01_H

bit 7	bit 6	bit 5	bit 4	bit 3	bit 2	bit 1	bit 0
PSEL3	PSEL2	PSEL1	PSEL0	NSEL3	NSEL2	NSEL1	NSEL0

bit 7-4 PSEL3: PSEL2: PSEL1: PSEL0: Positive Channel Select

0000 = A_{IN}0 (default)
0001 = A_{IN}1
0010 = A_{IN}2
0011 = A_{IN}3
0100 = A_{IN}4
0101 = A_{IN}5
0110 = A_{IN}6
0111 = A_{IN}7
1xxx = AINCOM (except when xxx = 111)
1111 = Reserved

bit 3-0 NSEL3: NSEL2: NSEL1: NSEL0: Negative Channel Select

0000 = A_{IN}0
0001 = A_{IN}1 (default)
0010 = A_{IN}2
0011 = A_{IN}3
0100 = A_{IN}4
0101 = A_{IN}5
0110 = A_{IN}6
0111 = A_{IN}7
1xxx = AINCOM (except when xxx = 111)
1111 = Reserved

ACR (Address 02_H) Analog Control RegisterReset Value = X0_H

bit 7	bit 6	bit 5	bit 4	bit 3	bit 2	bit 1	bit 0
DRDY	U/B	SPEED	BUFEN	BIT ORDER	RANGE	DR1	DR0

- bit 7 **DRDY**: Data Ready (Read Only)
This bit duplicates the state of the DRDY pin.
- bit 6 **U/B**: Data Format
0 = Bipolar (default)
1 = Unipolar

U/B	ANALOG INPUT	DIGITAL OUTPUT (Hex)
0	+FSR	0x7FFFFFFF
	Zero	0x000000
	-FSR	0x800000
1	+FSR	0xFFFFFFFF
	Zero	0x000000
	-FSR	0x000000

- bit 5 **SPEED**: Modulator Clock Speed
0 = $f_{MOD} = f_{OSC}/128$ (default)
1 = $f_{MOD} = f_{OSC}/256$
- bit 4 **BUFEN**: Buffer Enable
0 = Buffer Disabled (default)
1 = Buffer Enabled
- bit 3 **BIT ORDER**: Data Output Bit Order
0 = Most Significant Bit Transmitted First (default)
1 = Least Significant Bit Transmitted First
This configuration bit controls only the bit order within the byte of data that is shifted out. Data is always shifted out of the part most significant byte first. Data is always shifted into the part most significant bit first.
- bit 2 **RANGE**: Range Select
0 = Full-Scale Input Range equal to $\pm V_{REF}$ (default).
1 = Full-Scale Input Range equal to $\pm 1/2 V_{REF}$
NOTE: This allows reference voltages as high as AV_{DD} , but even with a 5V reference voltage the calibration must be performed with this bit set to 0.
- bit 1-0 **DR1: DR0**: Data Rate
($f_{OSC} = 2.4576\text{MHz}$, $SPEED = 0$)
00 = 15Hz (default)
01 = 7.5Hz
10 = 3.75Hz
11 = Reserved

ODAC (Address 03) Offset DACReset Value = 00_H

bit 7	bit 6	bit 5	bit 4	bit 3	bit 2	bit 1	bit 0
SIGN	OSET6	OSET5	OSET4	OSET3	OSET2	OSET1	OSET0

- bit 7 **SIGN**
0 = Positive
1 = Negative

$$\text{Offset} = \frac{V_{REF}}{2 \cdot \text{PGA}} \cdot \left(\frac{\text{OSET}[6:0]}{127} \right) \quad \text{RANGE} = 0$$

$$\text{Offset} = \frac{V_{REF}}{4 \cdot \text{PGA}} \cdot \left(\frac{\text{OSET}[6:0]}{127} \right) \quad \text{RANGE} = 1$$

NOTE: The offset DAC must be enabled after calibration or the calibration nullifies the effects.

DIO (Address 04_H) Data I/OReset Value = 00_H

bit 7	bit 6	bit 5	bit 4	bit 3	bit 2	bit 1	bit 0
DIO7	DIO6	DIO5	DIO4	DIO3	DIO2	DIO1	DIO0

If the IOCON register is configured for data, a value written to this register appears on the data I/O pins if the pin is configured as an output in the DIR register. Reading this register returns the value of the data I/O pins.

Bit 4 to bit 7 is not used in ADS1240.

DIR (Address 05_H) Direction Control for Data I/OReset Value = FF_H

bit 7	bit 6	bit 5	bit 4	bit 3	bit 2	bit 1	bit 0
DIR7	DIR6	DIR5	DIR4	DIR3	DIR2	DIR1	DIR0

Each bit controls whether the corresponding data I/O pin is an output (= 0) or input (= 1). The default power-up state is as inputs.

Bit 4 to bit 7 is not used in ADS1240.

IOCON (Address 06_H) I/O Configuration RegisterReset Value = 00_H

bit 7	bit 6	bit 5	bit 4	bit 3	bit 2	bit 1	bit 0
IO7	IO6	IO5	IO4	IO3	IO2	IO1	IO0

- bit 7-0 **IO7: IO0**: Data I/O Configuration
0 = Analog (default)
1 = Data

Configuring the pin as a data I/O pin allows it to be controlled through the DIO and DIR registers.

Bit 4 to bit 7 is not used in ADS1240.

OCR0 (Address 07_H) Offset Calibration Coefficient

(Least Significant Byte)

Reset Value = 00_H

bit 7	bit 6	bit 5	bit 4	bit 3	bit 2	bit 1	bit 0
OCR07	OCR06	OCR05	OCR04	OCR03	OCR02	OCR01	OCR00

OCR1 (Address 08_H) Offset Calibration Coefficient
(Middle Byte)

Reset Value = 00_H

bit 7	bit 6	bit 5	bit 4	bit 3	bit 2	bit 1	bit 0
OCR15	OCR14	OCR13	OCR12	OCR11	OCR10	OCR09	OCR08

OCR2 (Address 09_H) Offset Calibration Coefficient
(Most Significant Byte)

Reset Value = 00_H

bit 7	bit 6	bit 5	bit 4	bit 3	bit 2	bit 1	bit 0
OCR23	OCR22	OCR21	OCR20	OCR19	OCR18	OCR17	OCR16

FSR0 (Address 0A_H) Full-Scale Register
(Least Significant Byte)

Reset Value = 59_H

bit 7	bit 6	bit 5	bit 4	bit 3	bit 2	bit 1	bit 0
FSR07	FSR06	FSR05	FSR04	FSR03	FSR02	FSR01	FSR00

FSR1 (Address 0B_H) Full-Scale Register
(Middle Byte)

Reset Value = 55_H

bit 7	bit 6	bit 5	bit 4	bit 3	bit 2	bit 1	bit 0
FSR15	FSR14	FSR13	FSR12	FSR11	FSR10	FSR09	FSR08

FSR2 (Address 0C_H) Full-Scale Register
(Most Significant Byte)

Reset Value = 55_H

bit 7	bit 6	bit 5	bit 4	bit 3	bit 2	bit 1	bit 0
FSR23	FSR22	FSR21	FSR20	FSR19	FSR18	FSR17	FSR16

DOR2 (Address 0D_H) Data Output Register
(Most Significant Byte) (Read Only)

Reset Value = 00_H

bit 7	bit 6	bit 5	bit 4	bit 3	bit 2	bit 1	bit 0
DOR23	DOR22	DOR21	DOR20	DOR19	DOR18	DOR17	DOR16

DOR1 (Address 0E_H) Data Output Register
(Middle Byte) (Read Only)

Reset Value = 00_H

bit 7	bit 6	bit 5	bit 4	bit 3	bit 2	bit 1	bit 0
DOR15	DOR14	DOR13	DOR12	DOR11	DOR10	DOR09	DOR08

DOR0 (Address 0F_H) Data Output Register
(Least Significant Byte) (Read Only)

Reset Value = 00_H

bit 7	bit 6	bit 5	bit 4	bit 3	bit 2	bit 1	bit 0
DOR07	DOR06	DOR05	DOR04	DOR03	DOR02	DOR01	DOR00

ADS1240 AND ADS1241 CONTROL COMMAND DEFINITIONS

The commands listed in Table IV control the operations of the ADS1240 and ADS1241. Some of the commands are stand-alone commands (e.g., RESET) while others require additional bytes (e.g., WREG requires the count and data bytes).

Operands:

n = count (0 to 127)

r = register (0 to 15)

x = don't care

COMMANDS	DESCRIPTION	OP CODE	2 nd COMMAND BYTE
RDATA	Read Data	0000 0001 (01 _H)	—
RDATA C	Read Data Continuously	0000 0011 (03 _H)	—
STOPC	Stop Read Data Continuously	0000 1111 (0F _H)	—
RREG	Read from REG “rrrr”	0001 r r r r (1x _H)	xxxx_nnnn (# of regs-1)
WREG	Write to REG “rrrr”	0101 r r r r (5x _H)	xxxx_nnnn (# of regs-1)
SELF CAL	Offset and Gain Self Cal	1111 0000 (F0 _H)	—
SELF OCAL	Self Offset Cal	1111 0001 (F1 _H)	—
SELF GCAL	Self Gain Cal	1111 0010 (F2 _H)	—
SYSOCAL	Sys Offset Cal	1111 0011 (F3 _H)	—
SYSGCAL	Sys Gain Cal	1111 0100 (F4 _H)	—
WAKEUP	Wakeup from SLEEP Mode	1111 1011 (FB _H)	—
DSYNC	Sync $\overline{\text{DRDY}}$	1111 1100 (FC _H)	—
SLEEP	Put in SLEEP Mode	1111 1101 (FD _H)	—
RESET	Reset to Power-Up Values	1111 1110 (FE _H)	—

NOTE: The received data format is always MSB First; the data out format is set by the BIT ORDER bit in the ACR register.

TABLE IV. Command Summary.

RDATA—Read Data

Description: Read the most recent conversion result from the Data Output Register (DOR). This is a 24-bit value.

Operands: None

Bytes: 1

Encoding: 0000 0001

Data Transfer Sequence:

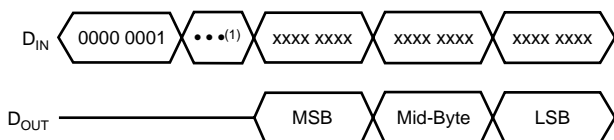

NOTE: (1) For wait time, refer to timing specification.

RDATA C—Read Data Continuous

Description: Read Data Continuous mode enables the continuous output of new data on each $\overline{\text{DRDY}}$. This command eliminates the need to send the Read Data Command on each $\overline{\text{DRDY}}$. This mode may be terminated by either the STOPC command or the RESET command. Wait at least 10 f_{OSC} after $\overline{\text{DRDY}}$ falls before reading.

Operands: None

Bytes: 1

Encoding: 0000 0011

Data Transfer Sequence:

Command terminated when “uuuu uuuu” equals STOPC or RESET.

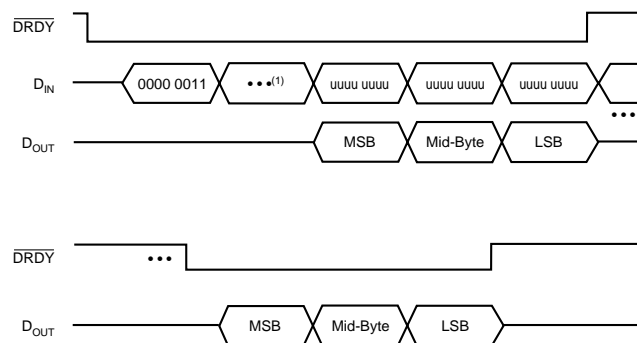

NOTE: (1) For wait time, refer to timing specification.

STOPC—Stop Continuous

Description: Ends the continuous data output mode. Issue after $\overline{\text{DRDY}}$ goes LOW.

Operands: None

Bytes: 1

Encoding: 0000 1111

Data Transfer Sequence:

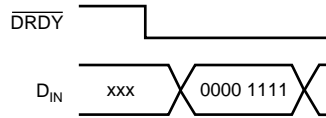

RREG—Read from Registers

Description: Output the data from up to 16 registers starting with the register address specified as part of the instruction. The number of registers read will be one plus the second byte count. If the count exceeds the remaining registers, the addresses wrap back to the beginning.

Operands: r, n

Bytes: 2

Encoding: 0001 rrrr xxxx nnnn

Data Transfer Sequence:

Read Two Registers Starting from Register 01_H (MUX)

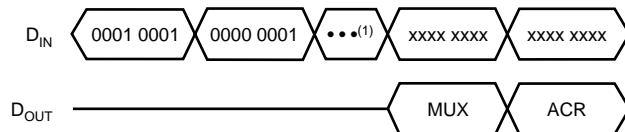

NOTE: (1) For wait time, refer to timing specification.

WREG—Write to Registers

Description: Write to the registers starting with the register address specified as part of the instruction. The number of registers that will be written is one plus the value of the second byte.

Operands: r, n

Bytes: 2

Encoding: 0101 rrrr xxxx nnnn

Data Transfer Sequence:

Write Two Registers Starting from 04_H (DIO)

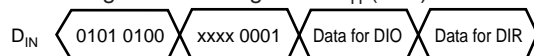

SELFAL—Offset and Gain Self Calibration

Description: Starts the process of self calibration. The Offset Calibration Register (OCR) and the Full-Scale Register (FSR) are updated with new values after this operation.

Operands: None

Bytes: 1

Encoding: 1111 0000

Data Transfer Sequence:

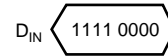

SELFOCAL—Offset Self Calibration

Description: Starts the process of self-calibration for offset. The Offset Calibration Register (OCR) is updated after this operation.

Operands: None

Bytes: 1

Encoding: 1111 0001

Data Transfer Sequence:

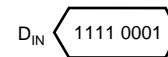

SELFGCAL—Gain Self Calibration

Description: Starts the process of self-calibration for gain. The Full-Scale Register (FSR) is updated with new values after this operation.

Operands: None

Bytes: 1

Encoding: 1111 0010

Data Transfer Sequence:

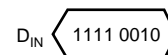

SYSOCAL–System Offset Calibration

Description: Initiates a system offset calibration. The input should be set to 0V, and the ADS1240 and ADS1241 compute the OCR value that compensates for offset errors. The Offset Calibration Register (OCR) is updated after this operation. The user must apply a zero input signal to the appropriate analog inputs. The OCR register is automatically updated afterwards.

Operands: None

Bytes: 1

Encoding: 1111 0011

Data Transfer Sequence:

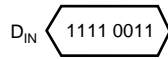

SYSGCAL–System Gain Calibration

Description: Starts the system gain calibration process. For a system gain calibration, the input should be set to the reference voltage and the ADS1240 and ADS1241 compute the FSR value that will compensate for gain errors. The FSR is updated after this operation. To initiate a system gain calibration, the user must apply a full-scale input signal to the appropriate analog inputs. FCR register is updated automatically.

Operands: None

Bytes: 1

Encoding: 1111 0100

Data Transfer Sequence:

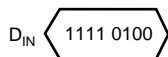

WAKEUP

Description: Wakes the ADS1240 and ADS1241 from SLEEP mode.

Operands: None

Bytes: 1

Encoding: 1111 1011

Data Transfer Sequence:

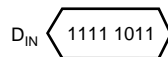

DSYNC–Sync \overline{DRDY}

Description: Synchronizes the ADS1240 and ADS1241 to an external event.

Operands: None

Bytes: 1

Encoding: 1111 1100

Data Transfer Sequence:

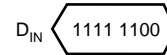

SLEEP–Sleep Mode

Description: Puts the ADS1240 and ADS1241 into a low power sleep mode. To exit sleep mode, issue the WAKEUP command.

Operands: None

Bytes: 1

Encoding: 1111 1101

Data Transfer Sequence:

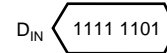

RESET–Reset to Default Values

Description: Restore the registers to their power-up values. This command stops the Read Continuous mode.

Operands: None

Bytes: 1

Encoding: 1111 1110

Data Transfer Sequence:

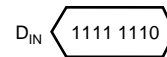

APPLICATION EXAMPLES

GENERAL-PURPOSE WEIGH SCALE

Figure 8 shows a typical schematic of a general-purpose weigh scale application using the ADS1240. In this example, the internal PGA is set to either 64 or 128 (depending on the maximum output voltage of the load cell) so that the load cell

output can be directly applied to the differential inputs of ADS1240.

HIGH PRECISION WEIGH SCALE

Figure 9 shows the typical schematic of a high-precision weigh scale application using the ADS1240. The front-end differential amplifier helps maximize the dynamic range.

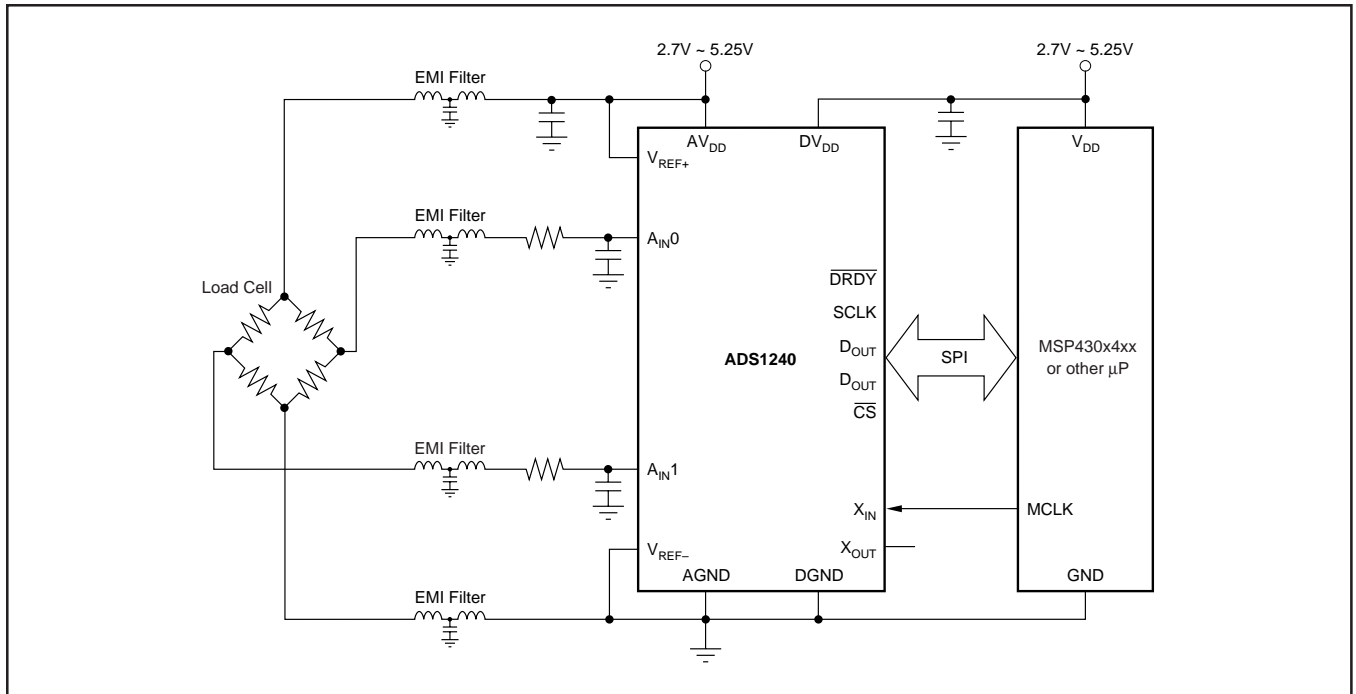

FIGURE 8. Schematic of a General-Purpose Weigh Scale.

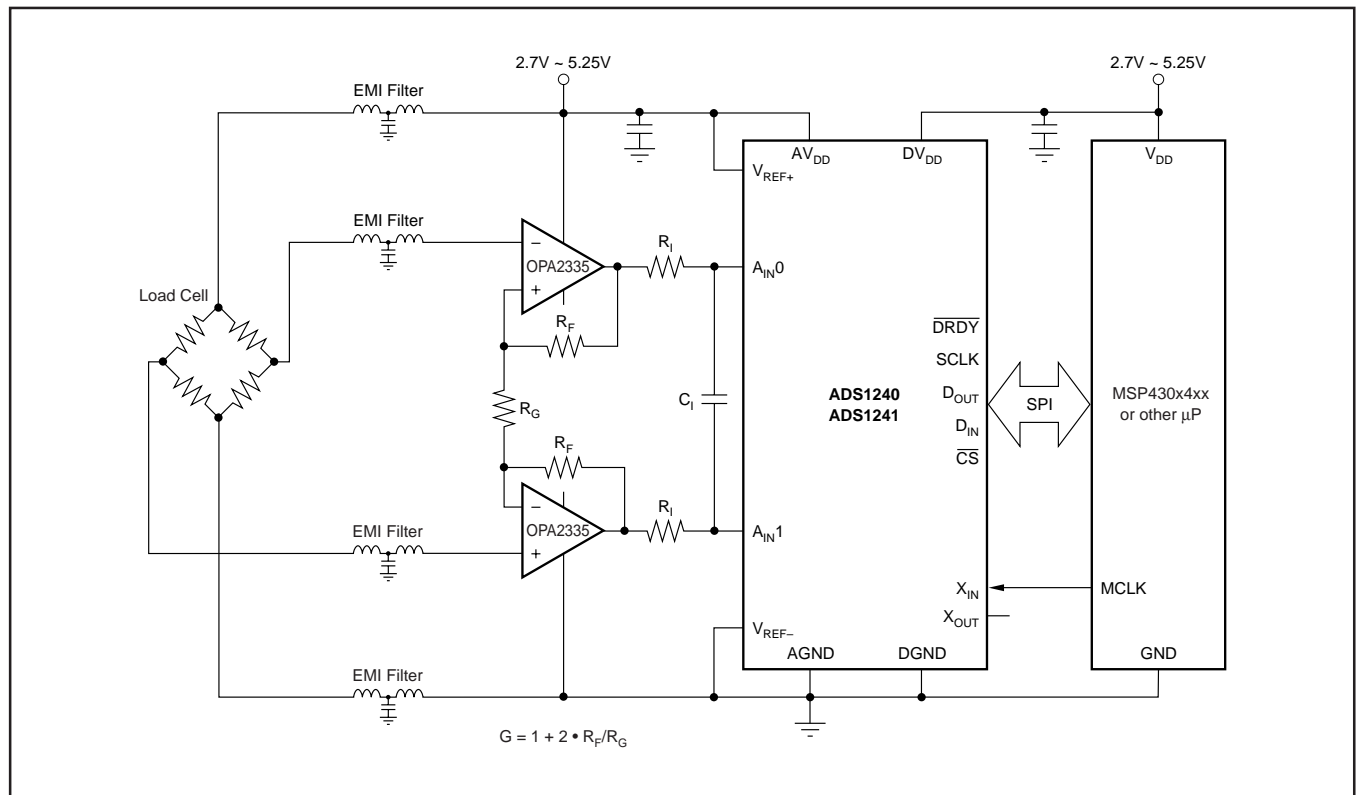

FIGURE 9. Block Diagram for a High-Precision Weigh Scale.

DEFINITION OF TERMS

An attempt has been made to be consistent with the terminology used in this data sheet. In that regard, the definition of each term is given as follows:

Analog Input Voltage—the voltage at any one analog input relative to AGND.

Analog Input Differential Voltage—given by the following equation: (IN+) – (IN–). Thus, a positive digital output is produced whenever the analog input differential voltage is positive, while a negative digital output is produced whenever the differential is negative.

For example, when the converter is configured with a 2.5V reference and placed in a gain setting of 1, the positive full-scale output is produced when the analog input differential is 2.5V. The negative full-scale output is produced when the differential is –2.5V. In each case, the actual input voltages must remain within the AGND to AV_{DD} range.

Conversion Cycle—the term *conversion cycle* usually refers to a discrete A/D conversion operation, such as that performed by a successive approximation converter. As used here, a conversion cycle refers to the t_{DATA} time period.

Data Rate—The rate at which conversions are completed. See definition for f_{DATA}.

$$f_{\text{DATA}} = \frac{f_{\text{OSC}}}{128 \cdot 2^{\text{SPEED}} \cdot 1280 \cdot 2^{\text{DR}}}$$

SPEED = 0, 1
DR = 0, 1, 2

f_{OSC}—the frequency of the crystal oscillator or CMOS compatible input signal at the X_{IN} input of the ADS1240 and ADS1241.

f_{MOD}—the frequency or speed at which the modulator of the ADS1240 and ADS1241 is running. This depends on the SPEED bit as given by the following equation:

$$f_{\text{MOD}} = \frac{f_{\text{OSC}}}{\text{mfactor}} = \frac{f_{\text{OSC}}}{128 \cdot 2^{\text{SPEED}}}$$

f_{SAMP}—the frequency, or switching speed, of the input sam-

PGA SETTING	SAMPLING FREQUENCY
1, 2, 4, 8	$f_{\text{SAMP}} = \frac{f_{\text{OSC}}}{\text{mfactor}}$
16	$f_{\text{SAMP}} = \frac{f_{\text{OSC}} \cdot 2}{\text{mfactor}}$
32	$f_{\text{SAMP}} = \frac{f_{\text{OSC}} \cdot 4}{\text{mfactor}}$
64, 128	$f_{\text{SAMP}} = \frac{f_{\text{OSC}} \cdot 8}{\text{mfactor}}$

pling capacitor. The value is given by one of the following equations:

f_{DATA}—the frequency of the digital output data produced by the ADS1240 and ADS1241, f_{DATA} is also referred to as the Data Rate.

Full-Scale Range (FSR)—as with most A/D converters, the full-scale range of the ADS1240 and ADS1241 is defined as the input, that produces the positive full-scale digital output minus the input, that produces the negative full-scale digital output.

For example, when the converter is configured with a 2.5V reference and is placed in a gain setting of 2, the full-scale range is: [1.25V (positive full-scale) minus –1.25V (negative full-scale)] = 2.5V.

Least Significant Bit (LSB) Weight—this is the theoretical amount of voltage that the differential voltage at the analog input has to change in order to observe a change in the output data of one least significant bit. It is computed as follows:

$$\text{LSB Weight} = \frac{\text{Full-Scale Range}}{2^N - 1}$$

where N is the number of bits in the digital output.

t_{DATA}—the inverse of f_{DATA}, or the period between each data output.

	SPEED = 0	SPEED = 1
mfactor	128	256

GAIN SETTING	5V SUPPLY ANALOG INPUT ⁽¹⁾			GENERAL EQUATIONS		
	FULL-SCALE RANGE	DIFFERENTIAL INPUT VOLTAGES ⁽²⁾	PGA OFFSET RANGE	FULL-SCALE RANGE	DIFFERENTIAL INPUT VOLTAGES ⁽²⁾	PGA SHIFT RANGE
1	5V	±2.5V	±1.25V	$\frac{2 \cdot V_{\text{REF}}}{\text{PGA}}$	$\frac{\pm V_{\text{REF}}}{\text{PGA}}$	$\frac{\pm V_{\text{REF}}}{2 \cdot \text{PGA}}$
2	2.5V	±1.25V	±0.625V			
4	1.25V	±0.625V	±312.5mV	RANGE = 0		
8	0.625V	±312.5mV	±156.25mV	$\frac{V_{\text{REF}}}{\text{PGA}}$	$\frac{\pm V_{\text{REF}}}{2 \cdot \text{PGA}}$	$\frac{\pm V_{\text{REF}}}{4 \cdot \text{PGA}}$
16	312.5mV	±156.25mV	±78.125mV			
32	156.25mV	±78.125mV	±39.0625mV			
64	78.125mV	±39.0625mV	±19.531mV			
128	39.0625mV	±19.531mV	±9.766mV	RANGE = 1		

NOTES: (1) With a 2.5V reference. (2) Refer to electrical specification for analog input voltage range.

TABLE VI. Full-Scale Range versus PGA Setting.

Revision History

DATE	REVISION	PAGE	SECTION	DESCRIPTION
8/06	E	6	Timing Characteristics Table	Clarified t_{10} specification.

NOTE: Page numbers for previous revisions may differ from page numbers in the current version.

PACKAGING INFORMATION

Orderable Device	Status ⁽¹⁾	Package Type	Package Drawing	Pins	Package Qty	Eco Plan ⁽²⁾	Lead/Ball Finish	MSL Peak Temp ⁽³⁾
ADS1240E	ACTIVE	SSOP	DB	24	60	Green (RoHS & no Sb/Br)	CU NIPDAU	Level-1-260C-UNLIM
ADS1240E/1K	ACTIVE	SSOP	DB	24	1000	Green (RoHS & no Sb/Br)	CU NIPDAU	Level-1-260C-UNLIM
ADS1240E/1KG4	ACTIVE	SSOP	DB	24	1000	Green (RoHS & no Sb/Br)	CU NIPDAU	Level-1-260C-UNLIM
ADS1240EG4	ACTIVE	SSOP	DB	24	60	Green (RoHS & no Sb/Br)	CU NIPDAU	Level-1-260C-UNLIM
ADS1241E	ACTIVE	SSOP	DB	28	48	Green (RoHS & no Sb/Br)	CU NIPDAU	Level-1-260C-UNLIM
ADS1241E/1K	ACTIVE	SSOP	DB	28	1000	Green (RoHS & no Sb/Br)	CU NIPDAU	Level-1-260C-UNLIM
ADS1241E/1KG4	ACTIVE	SSOP	DB	28	1000	Green (RoHS & no Sb/Br)	CU NIPDAU	Level-1-260C-UNLIM
ADS1241EG4	ACTIVE	SSOP	DB	28	48	Green (RoHS & no Sb/Br)	CU NIPDAU	Level-1-260C-UNLIM

⁽¹⁾ The marketing status values are defined as follows:

ACTIVE: Product device recommended for new designs.

LIFEBUY: TI has announced that the device will be discontinued, and a lifetime-buy period is in effect.

NRND: Not recommended for new designs. Device is in production to support existing customers, but TI does not recommend using this part in a new design.

PREVIEW: Device has been announced but is not in production. Samples may or may not be available.

OBSOLETE: TI has discontinued the production of the device.

⁽²⁾ Eco Plan - The planned eco-friendly classification: Pb-Free (RoHS), Pb-Free (RoHS Exempt), or Green (RoHS & no Sb/Br) - please check <http://www.ti.com/productcontent> for the latest availability information and additional product content details.

TBD: The Pb-Free/Green conversion plan has not been defined.

Pb-Free (RoHS): TI's terms "Lead-Free" or "Pb-Free" mean semiconductor products that are compatible with the current RoHS requirements for all 6 substances, including the requirement that lead not exceed 0.1% by weight in homogeneous materials. Where designed to be soldered at high temperatures, TI Pb-Free products are suitable for use in specified lead-free processes.

Pb-Free (RoHS Exempt): This component has a RoHS exemption for either 1) lead-based flip-chip solder bumps used between the die and package, or 2) lead-based die adhesive used between the die and leadframe. The component is otherwise considered Pb-Free (RoHS compatible) as defined above.

Green (RoHS & no Sb/Br): TI defines "Green" to mean Pb-Free (RoHS compatible), and free of Bromine (Br) and Antimony (Sb) based flame retardants (Br or Sb do not exceed 0.1% by weight in homogeneous material)

⁽³⁾ MSL, Peak Temp. -- The Moisture Sensitivity Level rating according to the JEDEC industry standard classifications, and peak solder temperature.

Important Information and Disclaimer:The information provided on this page represents TI's knowledge and belief as of the date that it is provided. TI bases its knowledge and belief on information provided by third parties, and makes no representation or warranty as to the accuracy of such information. Efforts are underway to better integrate information from third parties. TI has taken and continues to take reasonable steps to provide representative and accurate information but may not have conducted destructive testing or chemical analysis on incoming materials and chemicals. TI and TI suppliers consider certain information to be proprietary, and thus CAS numbers and other limited information may not be available for release.

In no event shall TI's liability arising out of such information exceed the total purchase price of the TI part(s) at issue in this document sold by TI to Customer on an annual basis.

TAPE AND REEL INFORMATION

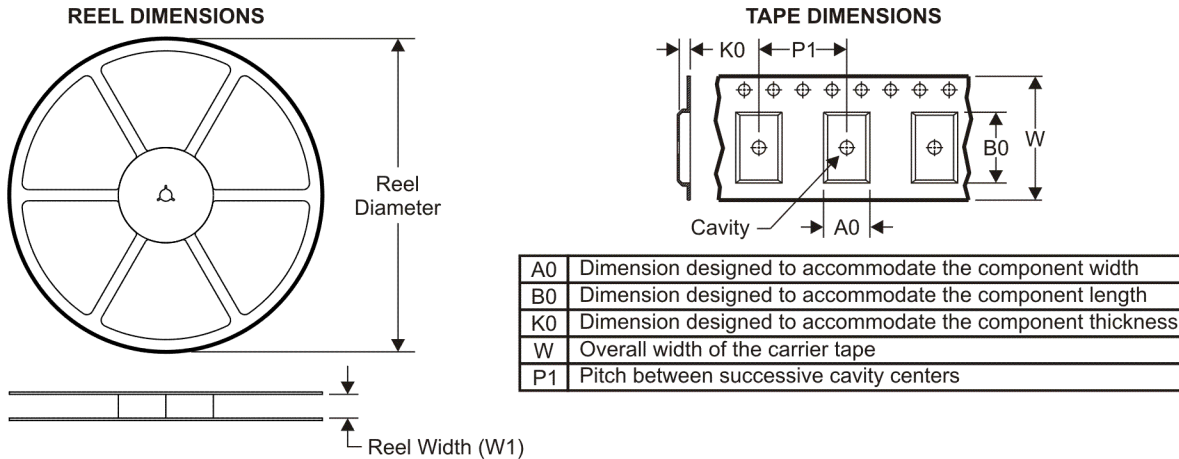

QUADRANT ASSIGNMENTS FOR PIN 1 ORIENTATION IN TAPE

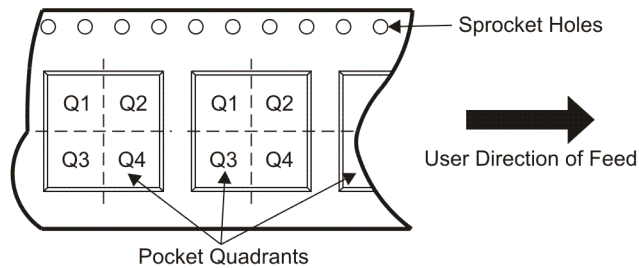

*All dimensions are nominal

Device	Package Type	Package Drawing	Pins	SPQ	Reel Diameter (mm)	Reel Width W1 (mm)	A0 (mm)	B0 (mm)	K0 (mm)	P1 (mm)	W (mm)	Pin1 Quadrant
ADS1240E/1K	SSOP	DB	24	1000	330.0	16.4	8.2	8.8	2.5	12.0	16.0	Q1
ADS1241E/1K	SSOP	DB	28	1000	330.0	16.4	8.2	10.5	2.5	12.0	16.0	Q1

TAPE AND REEL BOX DIMENSIONS

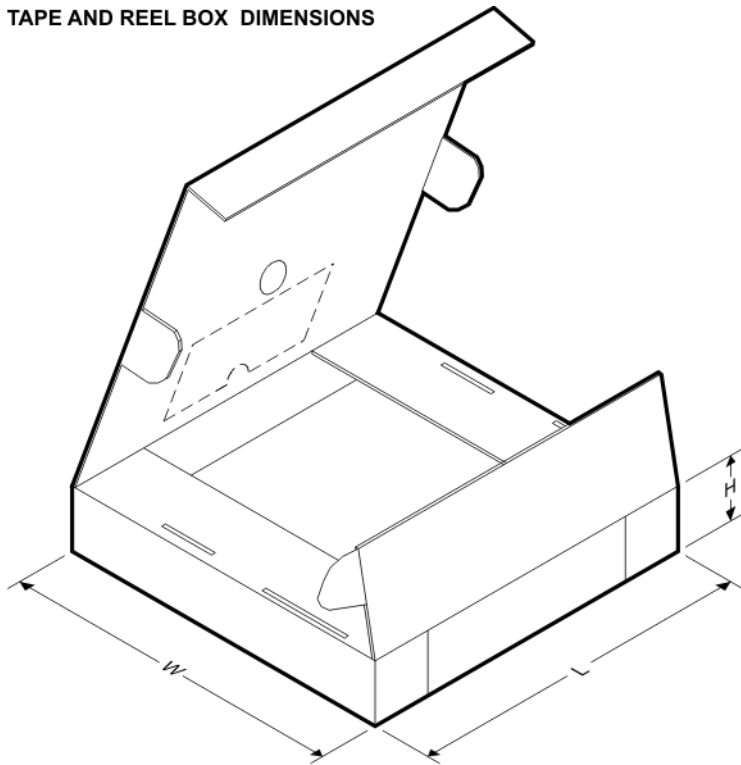

*All dimensions are nominal

Device	Package Type	Package Drawing	Pins	SPQ	Length (mm)	Width (mm)	Height (mm)
ADS1240E/1K	SSOP	DB	24	1000	346.0	346.0	33.0
ADS1241E/1K	SSOP	DB	28	1000	346.0	346.0	33.0

DB (R-PDSO-G**)

PLASTIC SMALL-OUTLINE

28 PINS SHOWN



- NOTES: A. All linear dimensions are in millimeters.
 B. This drawing is subject to change without notice.
 C. Body dimensions do not include mold flash or protrusion not to exceed 0,15.
 D. Falls within JEDEC MO-150

IMPORTANT NOTICE

Texas Instruments Incorporated and its subsidiaries (TI) reserve the right to make corrections, modifications, enhancements, improvements, and other changes to its products and services at any time and to discontinue any product or service without notice. Customers should obtain the latest relevant information before placing orders and should verify that such information is current and complete. All products are sold subject to TI's terms and conditions of sale supplied at the time of order acknowledgment.

TI warrants performance of its hardware products to the specifications applicable at the time of sale in accordance with TI's standard warranty. Testing and other quality control techniques are used to the extent TI deems necessary to support this warranty. Except where mandated by government requirements, testing of all parameters of each product is not necessarily performed.

TI assumes no liability for applications assistance or customer product design. Customers are responsible for their products and applications using TI components. To minimize the risks associated with customer products and applications, customers should provide adequate design and operating safeguards.

TI does not warrant or represent that any license, either express or implied, is granted under any TI patent right, copyright, mask work right, or other TI intellectual property right relating to any combination, machine, or process in which TI products or services are used. Information published by TI regarding third-party products or services does not constitute a license from TI to use such products or services or a warranty or endorsement thereof. Use of such information may require a license from a third party under the patents or other intellectual property of the third party, or a license from TI under the patents or other intellectual property of TI.

Reproduction of TI information in TI data books or data sheets is permissible only if reproduction is without alteration and is accompanied by all associated warranties, conditions, limitations, and notices. Reproduction of this information with alteration is an unfair and deceptive business practice. TI is not responsible or liable for such altered documentation. Information of third parties may be subject to additional restrictions.

Resale of TI products or services with statements different from or beyond the parameters stated by TI for that product or service voids all express and any implied warranties for the associated TI product or service and is an unfair and deceptive business practice. TI is not responsible or liable for any such statements.

TI products are not authorized for use in safety-critical applications (such as life support) where a failure of the TI product would reasonably be expected to cause severe personal injury or death, unless officers of the parties have executed an agreement specifically governing such use. Buyers represent that they have all necessary expertise in the safety and regulatory ramifications of their applications, and acknowledge and agree that they are solely responsible for all legal, regulatory and safety-related requirements concerning their products and any use of TI products in such safety-critical applications, notwithstanding any applications-related information or support that may be provided by TI. Further, Buyers must fully indemnify TI and its representatives against any damages arising out of the use of TI products in such safety-critical applications.

TI products are neither designed nor intended for use in military/aerospace applications or environments unless the TI products are specifically designated by TI as military-grade or "enhanced plastic." Only products designated by TI as military-grade meet military specifications. Buyers acknowledge and agree that any such use of TI products which TI has not designated as military-grade is solely at the Buyer's risk, and that they are solely responsible for compliance with all legal and regulatory requirements in connection with such use.

TI products are neither designed nor intended for use in automotive applications or environments unless the specific TI products are designated by TI as compliant with ISO/TS 16949 requirements. Buyers acknowledge and agree that, if they use any non-designated products in automotive applications, TI will not be responsible for any failure to meet such requirements.

Following are URLs where you can obtain information on other Texas Instruments products and application solutions:

Products

Amplifiers	amplifier.ti.com
Data Converters	dataconverter.ti.com
DSP	dsp.ti.com
Clocks and Timers	www.ti.com/clocks
Interface	interface.ti.com
Logic	logic.ti.com
Power Mgmt	power.ti.com
Microcontrollers	microcontroller.ti.com
RFID	www.ti-rfid.com
RF/IF and ZigBee® Solutions	www.ti.com/lprf

Applications

Audio	www.ti.com/audio
Automotive	www.ti.com/automotive
Broadband	www.ti.com/broadband
Digital Control	www.ti.com/digitalcontrol
Medical	www.ti.com/medical
Military	www.ti.com/military
Optical Networking	www.ti.com/opticalnetwork
Security	www.ti.com/security
Telephony	www.ti.com/telephony
Video & Imaging	www.ti.com/video
Wireless	www.ti.com/wireless

Mailing Address: Texas Instruments, Post Office Box 655303, Dallas, Texas 75265
Copyright © 2008, Texas Instruments Incorporated