

- Low Supply-Voltage Range, 1.8 V to 3.6 V
- Ultralow-Power Consumption:
  - Active Mode: 200  $\mu$ A at 1 MHz, 2.2 V
  - Standby Mode: 0.7  $\mu$ A
  - Off Mode (RAM Retention): 0.1  $\mu$ A
- Five Power-Saving Modes
- Wake-Up From Standby Mode in less than 6  $\mu$ s
- Frequency-Locked Loop, FLL+
- 16-Bit RISC Architecture, 125-ns Instruction Cycle Time
- Scan IF for Background Water, Heat, and Gas Volume Measurement
- 16-Bit Timer\_A With Three Capture/Compare Registers
- 16-Bit Timer\_A With Five Capture/Compare Registers
- Integrated LCD Driver for Up to 96 Segments
- On-Chip Comparator
- Serial Onboard Programming, No External Programming Voltage Needed Programmable Code Protection by Security Fuse
- Brownout Detector
- Supply Voltage Supervisor/Monitor With Programmable Level Detection
- Bootstrap Loader in Flash Devices
- Family Members Include:
  - MSP430FW423: 8KB + 256B Flash Memory, 256B RAM
  - MSP430FW425: 16KB + 256B Flash Memory, 512B RAM
  - MSP430FW427: 32KB + 256B Flash Memory, 1KB RAM
- Available in 64-Pin Quad Flat Pack (QFP)
- For Complete Module Descriptions, Refer to the *MSP430x4xx Family User's Guide*, Literature Number SLAU056

## description

The Texas Instruments MSP430 family of ultralow power microcontrollers consist of several devices featuring different sets of peripherals targeted for various applications. The architecture, combined with five low power modes is optimized to achieve extended battery life in portable measurement applications. The device features a powerful 16-bit RISC CPU, 16-bit registers, and constant generators that attribute to maximum code efficiency. The digitally controlled oscillator (DCO) allows wake-up from low-power modes to active mode in less than 6 $\mu$ s.

The MSP430xW42x series are microcontroller configurations with two built-in 16-bit timers, a comparator, 96 LCD segment drive capability, a scan interface, and 48 I/O pins.

Typical applications include sensor systems that capture analog signals, convert them to digital values, and process the data and transmit them to a host system. The comparator and timers make the configurations ideal for gas, heat, and water meters, industrial meters, counter applications, handheld meters, etc.

### AVAILABLE OPTIONS

T <sub>A</sub>	PACKAGED DEVICES
	PLASTIC 64-PIN QFP (PM)
–40°C to 85°C	MSP430FW423IPM MSP430FW425IPM MSP430FW427IPM



Please be aware that an important notice concerning availability, standard warranty, and use in critical applications of Texas Instruments semiconductor products and disclaimers thereto appears at the end of this data sheet.

PRODUCTION DATA information is current as of publication date. Products conform to specifications per the terms of Texas Instruments standard warranty. Production processing does not necessarily include testing of all parameters.



# MSP430xW42x MIXED SIGNAL MICROCONTROLLER

SLAS383A – OCTOBER 2003 – REVISED AUGUST 2004

## pin designation, MSP430xW42x

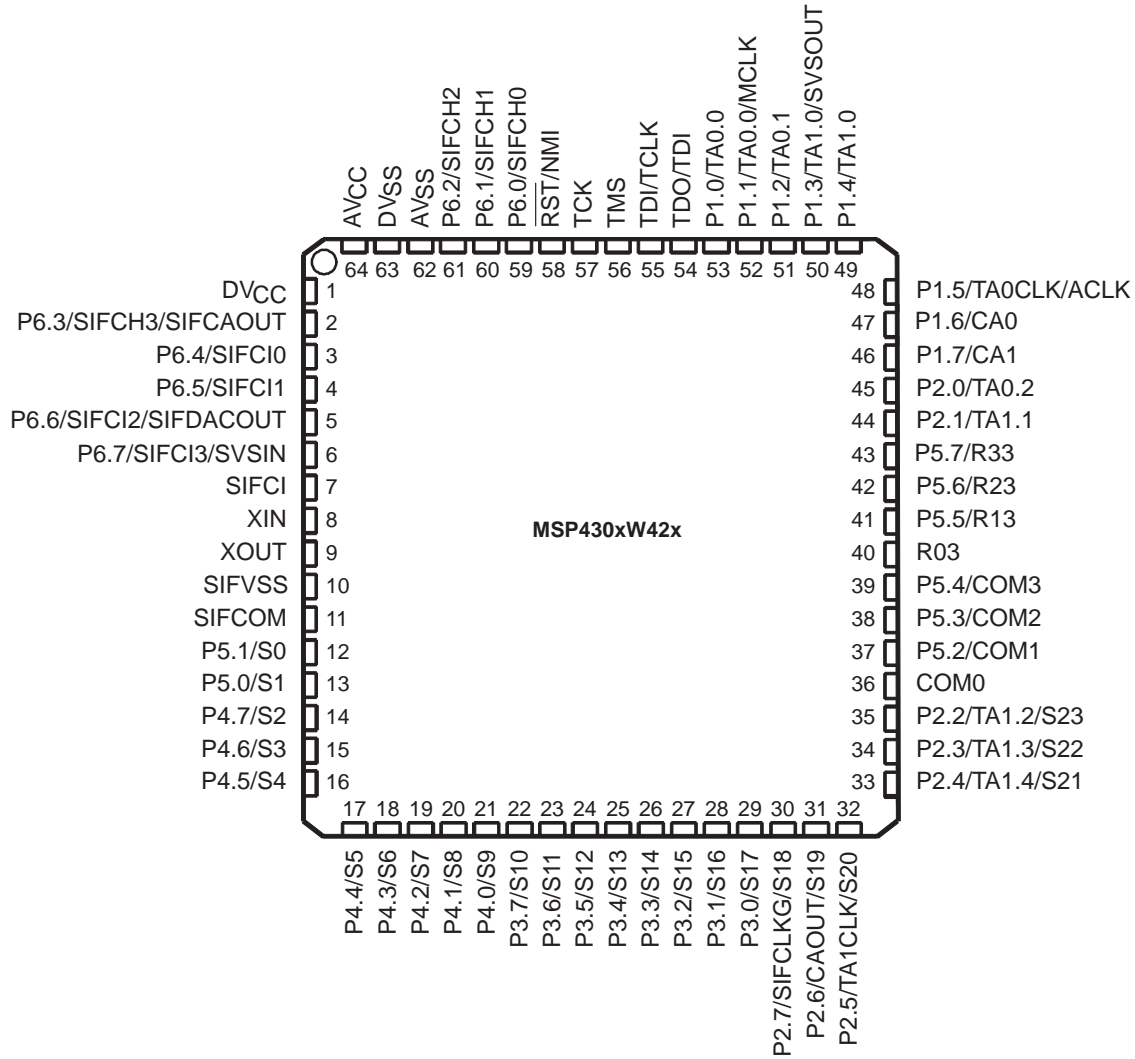

**functional block diagram**

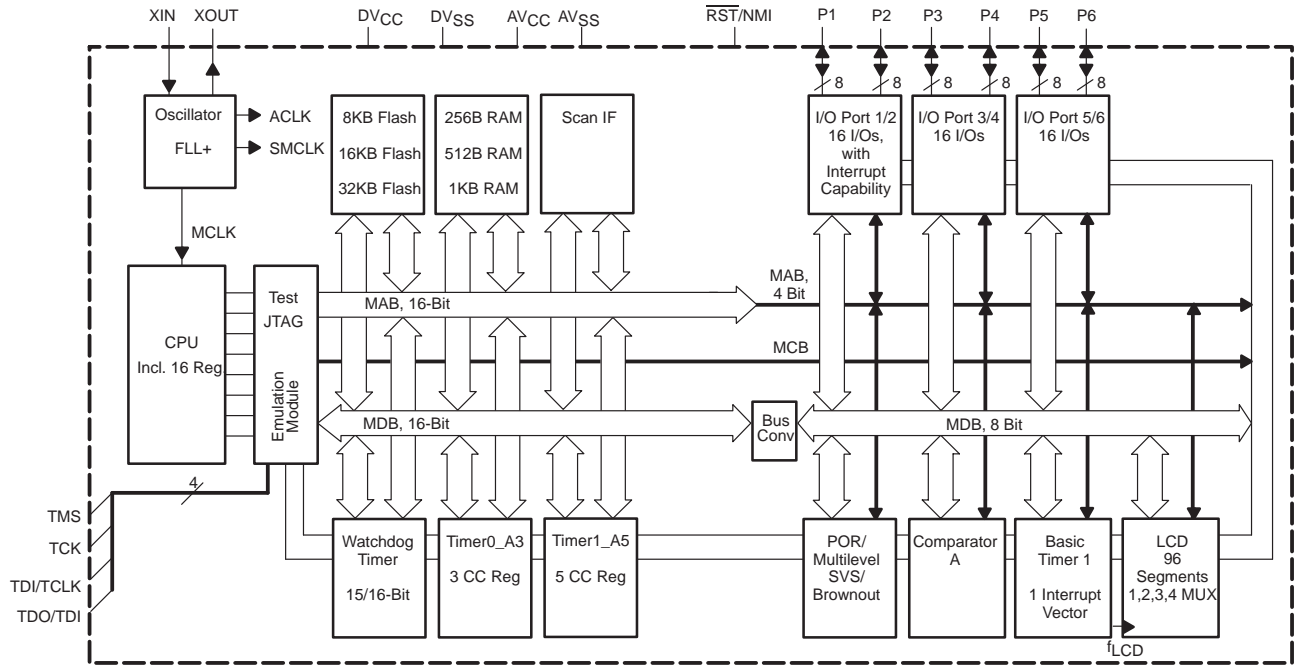

# MSP430xW42x MIXED SIGNAL MICROCONTROLLER

SLAS383A – OCTOBER 2003 – REVISED AUGUST 2004

## Terminal Functions

### MSP430xW42x

TERMINAL NAME	NO.	I/O	DESCRIPTION
AVCC	64		Analog supply voltage, positive terminal. Supplies SVS, brownout, oscillator, FLL+, comparator_A, scan IF AFE, port 6, and LCD resistive divider circuitry; must not power up prior to DVCC.
AVSS	62		Analog supply voltage, negative terminal. Supplies SVS, brownout, oscillator, FLL+, comparator_A, scan IF AFE, and port 6. Must be externally connected to DVSS. Internally connected to DVSS.
DVCC	1		Digital supply voltage, positive terminal.
DVSS	63		Digital supply voltage, negative terminal.
SIFVSS	10		Scan IF AFE reference supply voltage.
P1.0/TA0.0	53	I/O	General-purpose digital I/O/Timer0_A. Capture: CCI0A input, compare: Out0 output/BSL transmit
P1.1/TA0.0/MCLK	52	I/O	General-purpose digital I/O/Timer0_A. Capture: CCI0B input/MCLK output/BSL receive Note: TA0.0 is only an input on this pin.
P1.2/TA0.1	51	I/O	General-purpose digital I/O/Timer0_A, capture: CCI1A input, compare: Out1 output
P1.3/TA1.0/ SVSOUT	50	I/O	General-purpose digital I/O/Timer1_A, capture: CCI0B input/SVS: output of SVS comparator Note: TA1.0 is only an input on this pin.
P1.4/TA1.0	49	I/O	General-purpose digital I/O/Timer1_A, capture: CCI0A input, compare: Out0 output
P1.5/TA0CLK/ ACLK	48	I/O	General-purpose digital I/O/input of Timer0_A clock/output of ACLK
P1.6/CA0	47	I/O	General-purpose digital I/O/Comparator_A input
P1.7/CA1	46	I/O	General-purpose digital I/O/Comparator_A input
P2.0/TA0.2	45	I/O	General-purpose digital I/O/Timer0_A, capture: CCI2A input, compare: Out2 output
P2.1/TA1.1	44	I/O	General-purpose digital I/O/Timer0_A, capture: CCI1A input, compare: Out1 output
P2.2/TA1.2/S23	35	I/O	General-purpose digital I/O/Timer1_A, capture: CCI2A input, compare: Out2 output/LCD segment output 23 (see Note)
P2.3/TA1.3/S22	34	I/O	General-purpose digital I/O/Timer1_A, capture: CCI3A input, compare: Out3 output/LCD segment output 22 (see Note)
P2.4/TA1.4/S21	33	I/O	General-purpose digital I/O/Timer1_A, capture: CCI4A input, compare: Out4 output/LCD segment output 21 (see Note)
P2.5/TA1CLK/S20	32	I/O	General-purpose digital I/O/input of Timer1_A clock/LCD segment output 20 (see Note)
P2.6/CAOUT/S19	31	I/O	General-purpose digital I/O/Comparator_A output/LCD segment output 19 (see Note)
P2.7/SIFCLKG/ S18	30	I/O	General-purpose digital I/O/Scan IF, signal SIFCLKG from internal clock generator/LCD segment output 18 (see Note)
P3.0/S17	29	I/O	General-purpose digital I/O/ LCD segment output 17 (see Note)
P3.1/S16	28	I/O	General-purpose digital I/O/ LCD segment output 16 (see Note)
P3.2/S15	27	I/O	General-purpose digital I/O/ LCD segment output 15 (see Note)
P3.3/S14	26	I/O	General-purpose digital I/O/ LCD segment output 14 (see Note)
P3.4/S13	25	I/O	General-purpose digital I/O/LCD segment output 13 (see Note)
P3.5/S12	24	I/O	General-purpose digital I/O/LCD segment output 12 (see Note)
P3.6/S11	23	I/O	General-purpose digital I/O/LCD segment output 11 (see Note)
P3.7/S10	22	I/O	General-purpose digital I/O/LCD segment output 10 (see Note)

NOTE: LCD function selected automatically when applicable LCD module control bits are set, not with PxSEL bits.



**Terminal Functions (Continued)**

**MSP430xW42x**

TERMINAL NAME	NO.	I/O	DESCRIPTION
P4.0/S9	21	I/O	General-purpose digital I/O/LCD segment output 9 (see Note)
P4.1/S8	20	I/O	General-purpose digital I/O/LCD segment output 8 (see Note)
P4.2/S7	19	I/O	General-purpose digital I/O/LCD segment output 7 (see Note)
P4.3/S6	18	I/O	General-purpose digital I/O/LCD segment output 6 (see Note)
P4.4/S5	17	I/O	General-purpose digital I/O/LCD segment output 5 (see Note)
P4.5/S4	16	I/O	General-purpose digital I/O/LCD segment output 4 (see Note)
P4.6/S3	15	I/O	General-purpose digital I/O/LCD segment output 3 (see Note)
P4.7/S2	14	I/O	General-purpose digital I/O/LCD segment output 2 (see Note)
P5.0/S1	13	I/O	General-purpose digital I/O/LCD segment output 1 (see Note)
P5.1/S0	12	I/O	General-purpose digital I/O/LCD segment output 0 (see Note)
COM0	36	O	Common output. COM0–3 are used for LCD backplanes
P5.2/COM1	37	I/O	General-purpose digital I/O/common output. COM0–3 are used for LCD backplanes
P5.3/COM2	38	I/O	General-purpose digital I/O/common output. COM0–3 are used for LCD backplanes
P5.4/COM3	39	I/O	General-purpose digital I/O/common output. COM0–3 are used for LCD backplanes
R03	40	I	Input port of fourth positive (lowest) analog LCD level (V5)
P5.5/R13	41	I/O	General-purpose digital I/O/input port of third most positive analog LCD level (V4 or V3)
P5.6/R23	42	I/O	General-purpose digital I/O/input port of second most positive analog LCD level (V2)
P5.7/R33	43	I/O	General-purpose digital I/O/output port of most positive analog LCD level (V1)
P6.0/SIFCH0	59	I/O	General-purpose digital I/O/Scan IF, channel 0 sensor excitation output and signal input
P6.1/SIFCH1	60	I/O	General-purpose digital I/O/Scan IF, channel 1 sensor excitation output and signal input
P6.2/SIFCH2	61	I/O	General-purpose digital I/O/Scan IF, channel 2 sensor excitation output and signal input
P6.3/SIFCH3/ SIFCAOUT	2	I/O	General-purpose digital I/O/Scan IF, channel 3 sensor excitation output and signal input/Scan IF comparator output
P6.4/SIFCI0	3	I/O	General-purpose digital I/O/Scan IF, channel 0 signal input to comparator
P6.5/SIFCI1	4	I/O	General-purpose digital I/O/Scan IF, channel 1 signal input to comparator
P6.6/SIFCI2/ SIFDACOUT	5	I/O	General-purpose digital I/O/Scan IF, channel 2 signal input to comparator/10-bit DAC output
P6.7/ SIFCI3/SVSIN	6	I/O	General-purpose digital I/O/Scan IF, channel 3 signal input to comparator/SVS, analog input
SIFCI	7	I	Scan IF input to Comparator.
SIFCOM	11	O	Common termination for Scan IF sensors.
RST/NMI	58	I	Reset input or nonmaskable interrupt input port.
TCK	57	I	Test clock. TCK is the clock input port for device programming and test.
TDI/TCLK	55	I	Test data input or test clock input. The device protection fuse is connected to TDI/TCLK.
TDO/TDI	54	I/O	Test data output port. TDO/TDI data output or programming data input terminal.
TMS	56	I	Test mode select. TMS is used as an input port for device programming and test.
XIN	8	I	Input port for crystal oscillator XT1. Standard or watch crystals can be connected.
XOUT	9	O	Output terminal of crystal oscillator XT1.

NOTE: LCD function selected automatically when applicable LCD module control bits are set, not with PxSEL bits.

# MSP430xW42x MIXED SIGNAL MICROCONTROLLER

SLAS383A – OCTOBER 2003 – REVISED AUGUST 2004

## short-form description

### CPU

The MSP430 CPU has a 16-bit RISC architecture that is highly transparent to the application. All operations, other than program-flow instructions, are performed as register operations in conjunction with seven addressing modes for source operand and four addressing modes for destination operand.

The CPU is integrated with 16 registers that provide reduced instruction execution time. The register-to-register operation execution time is one cycle of the CPU clock.

Four of the registers, R0 to R3, are dedicated as program counter, stack pointer, status register, and constant generator respectively. The remaining registers are general-purpose registers.

Peripherals are connected to the CPU using data, address, and control buses, and can be handled with all instructions.

### instruction set

The instruction set consists of 51 instructions with three formats and seven address modes. Each instruction can operate on word and byte data. Table 1 shows examples of the three types of instruction formats; the address modes are listed in Table 2.

Program Counter	PC/R0
Stack Pointer	SP/R1
Status Register	SR/CG1/R2
Constant Generator	CG2/R3
General-Purpose Register	R4
General-Purpose Register	R5
General-Purpose Register	R6
General-Purpose Register	R7
General-Purpose Register	R8
General-Purpose Register	R9
General-Purpose Register	R10
General-Purpose Register	R11
General-Purpose Register	R12
General-Purpose Register	R13
General-Purpose Register	R14
General-Purpose Register	R15

**Table 1. Instruction Word Formats**

Dual operands, source-destination	e.g. ADD R4,R5	R4 + R5 ----> R5
Single operands, destination only	e.g. CALL R8	PC ---->(TOS), R8----> PC
Relative jump, un/conditional	e.g. JNE	Jump-on-equal bit = 0

**Table 2. Address Mode Descriptions**

ADDRESS MODE	S	D	SYNTAX	EXAMPLE	OPERATION
Register	•	•	MOV Rs,Rd	MOV R10,R11	R10 ----> R11
Indexed	•	•	MOV X(Rn),Y(Rm)	MOV 2(R5),6(R6)	M(2+R5)----> M(6+R6)
Symbolic (PC relative)	•	•	MOV EDE,TONI		M(EDE) ----> M(TONI)
Absolute	•	•	MOV &MEM,&TCDAT		M(MEM) ----> M(TCDAT)
Indirect	•		MOV @Rn,Y(Rm)	MOV @R10,Tab(R6)	M(R10) ----> M(Tab+R6)
Indirect autoincrement	•		MOV @Rn+,Rm	MOV @R10+,R11	M(R10) ----> R11 R10 + 2----> R10
Immediate	•		MOV #X,TONI	MOV #45,TONI	#45 ----> M(TONI)

NOTE: S = source D = destination



## operating modes

The MSP430 has one active mode and five software selectable low-power modes of operation. An interrupt event can wake up the device from any of the five low-power modes, service the request and restore back to the low-power mode on return from the interrupt program.

The following six operating modes can be configured by software:

- Active mode AM;
  - All clocks are active
- Low-power mode 0 (LPM0);
  - CPU is disabled  
ACLK and SMCLK remain active, MCLK is available to modules  
FLL+ Loop control remains active
- Low-power mode 1 (LPM1);
  - CPU is disabled  
ACLK and SMCLK remain active, MCLK is available to modules  
FLL+ Loop control is disabled
- Low-power mode 2 (LPM2);
  - CPU is disabled  
MCLK and FLL+ loop control and DCOCLK are disabled  
DCO's dc-generator remains enabled  
ACLK remains active
- Low-power mode 3 (LPM3);
  - CPU is disabled  
MCLK, FLL+ loop control, and DCOCLK are disabled  
DCO's dc-generator is disabled  
ACLK remains active
- Low-power mode 4 (LPM4);
  - CPU is disabled  
ACLK is disabled  
MCLK, FLL+ loop control, and DCOCLK are disabled  
DCO's dc-generator is disabled  
Crystal oscillator is stopped

# MSP430xW42x MIXED SIGNAL MICROCONTROLLER

SLAS383A – OCTOBER 2003 – REVISED AUGUST 2004

## interrupt vector addresses

The interrupt vectors and the power-up starting address are located in the address range 0FFFh – 0FFE0h. The vector contains the 16-bit address of the appropriate interrupt-handler instruction sequence.

INTERRUPT SOURCE	INTERRUPT FLAG	SYSTEM INTERRUPT	WORD ADDRESS	PRIORITY
Power-up External Reset Watchdog Flash memory	WDTIFG KEYV (see Note 1)	Reset	0FFFEh	15, highest
NMI Oscillator Fault Flash memory access violation	NMIIFG OFIFG ACCVIFG (see Notes 1 & 3)	(Non)maskable (Non)maskable (Non)maskable	0FFFCh	14
Timer1_A5	TA1CCR0 CCIFG (see Note 2)	Maskable	0FFFAh	13
Timer1_A5	TA1CCR1 CCIFG to TA1CCR4 CCIFG, TA1CTL TAIFG (see Notes 1 & 2)	Maskable	0FFF8h	12
Comparator_A	CMPAIFG	Maskable	0FFF6h	11
Watchdog Timer	WDTIFG	Maskable	0FFF4h	10
Scan IF	SIFIFG0 to SIFIFG6 (See Note 1)	Maskable	0FFF2h	9
			0FFF0h	8
			0FFEEh	7
Timer0_A3	TA0CCR0 CCIFG (see Note 2)	Maskable	0FFECCh	6
Timer0_A3	TA0CCR1 CCIFG, TA0CCR2 CCIFG, TA0CTL TAIFG (see Notes 1 & 2)	Maskable	0FFEAh	5
I/O port P1 (eight flags)	P1IFG.0 to P1IFG.7 (see Notes 1 & 2)	Maskable	0FFE8h	4
			0FFE6h	3
			0FFE4h	2
I/O port P2 (eight flags)	P2IFG.0 to P2IFG.7 (see Notes 1 & 2)	Maskable	0FFE2h	1
Basic Timer1	BTIFG	Maskable	0FFE0h	0, lowest

- NOTES: 1. Multiple source flags  
 2. Interrupt flags are located in the module.  
 3. (Non)maskable: the individual interrupt-enable bit can disable an interrupt event, but the general interrupt-enable cannot.



## special function registers

Most interrupt and module enable bits are collected into the lowest address space. Special function register bits that are not allocated to a functional purpose are not physically present in the device. Simple software access is provided with this arrangement.

### interrupt enable 1 and 2

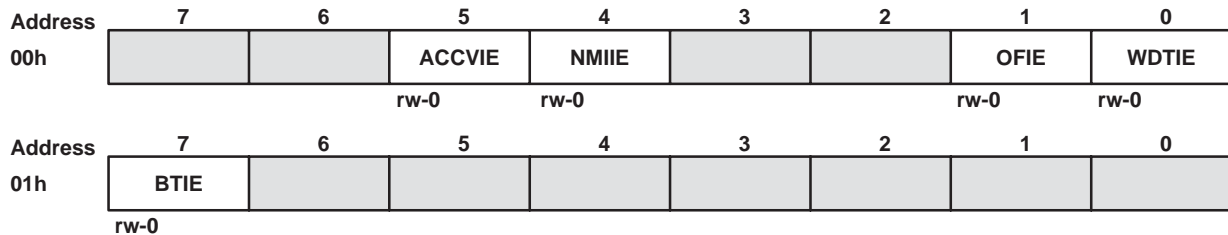

- WDTIE: Watchdog-timer interrupt enable. Inactive if watchdog mode is selected. Active if watchdog timer is configured in interval timer mode.
- OFIE: Oscillator-fault-interrupt enable
- NMIIE: Nonmaskable-interrupt enable
- ACCVIE: Flash access violation interrupt enable
- BTIE: Basic Timer1 interrupt enable

### interrupt flag register 1 and 2

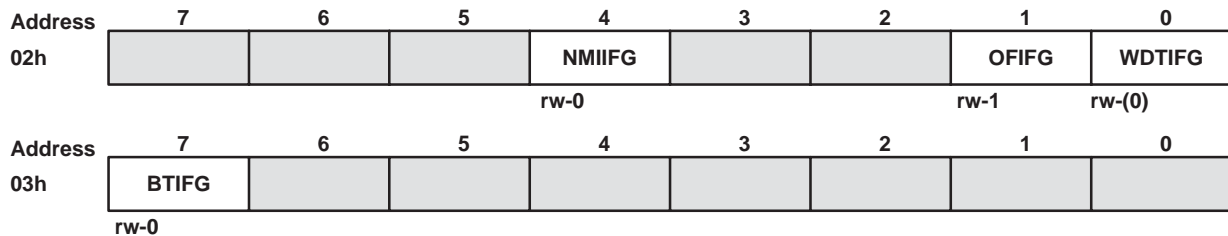

- WDTIFG: Set on watchdog-timer overflow (in watchdog mode) or security key violation. Reset with  $V_{CC}$  power-up, or a reset condition at the  $\overline{RST}/NMI$  pin in reset mode.
- OFIFG: Flag set on oscillator fault
- NMIIFG: Set via  $\overline{RST}/NMI$  pin
- BTIFG: Basic Timer1 interrupt flag

### module enable registers 1 and 2

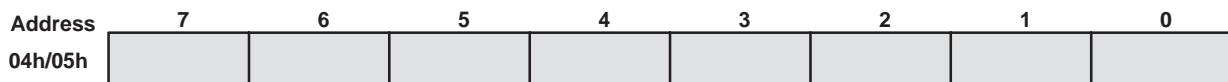

- Legend: rw: Bit Can Be Read and Written
- rw-0,1: Bit Can Be Read and Written. It Is Reset or Set by PUC.
- rw-(0,1): Bit Can Be Read and Written. It Is Reset or Set by POR.
- SFR Bit Not Present in Device

# MSP430xW42x MIXED SIGNAL MICROCONTROLLER

SLAS383A – OCTOBER 2003 – REVISED AUGUST 2004

## memory organization

		MSP430FW423	MSP430FW425	MSP430FW427
Memory	Size	8KB	16KB	32KB
Interrupt vector	Flash	0FFFFh – 0FFE0h	0FFFFh – 0FFE0h	0FFFFh – 0FFE0h
Code memory	Flash	0FFFFh – 0E000h	0FFFFh – 0C000h	0FFFFh – 08000h
Information memory	Size	256 Byte 010FFh – 01000h	256 Byte 010FFh – 01000h	256 Byte 010FFh – 01000h
Boot memory	Size	1KB 0FFFh – 0C00h	1KB 0FFFh – 0C00h	1KB 0FFFh – 0C00h
RAM	Size	256 Byte 02FFh – 0200h	512 Byte 03FFh – 0200h	1KB 05FFh – 0200h
Peripherals	16-bit	01FFh – 0100h	01FFh – 0100h	01FFh – 0100h
	8-bit	0FFh – 010h	0FFh – 010h	0FFh – 010h
	8-bit SFR	0Fh – 00h	0Fh – 00h	0Fh – 00h

## bootstrap loader (BSL)

The MSP430 bootstrap loader (BSL) enables users to program the flash memory or RAM using a UART serial interface. Access to the MSP430 memory via the BSL is protected by user-defined password. For complete description of the features of the BSL and its implementation, see the Application report *Features of the MSP430 Bootstrap Loader*, Literature Number SLAA089.

BSL Function	PM Package Pins
Data Transmit	53 - P1.0
Data Receive	52 - P1.1

## flash memory

The flash memory can be programmed via the JTAG port, the bootstrap loader, or in-system by the CPU. The CPU can perform single-byte and single-word writes to the flash memory. Features of the flash memory include:

- Flash memory has n segments of main memory and two segments of information memory (A and B) of 128 bytes each. Each segment in main memory is 512 bytes in size.
- Segments 0 to n may be erased in one step, or each segment may be individually erased.
- Segments A and B can be erased individually, or as a group with segments 0–n. Segments A and B are also called *information memory*.
- New devices may have some bytes programmed in the information memory (needed for test during manufacturing). The user should perform an erase of the information memory prior to the first use.

**flash memory (continued)**

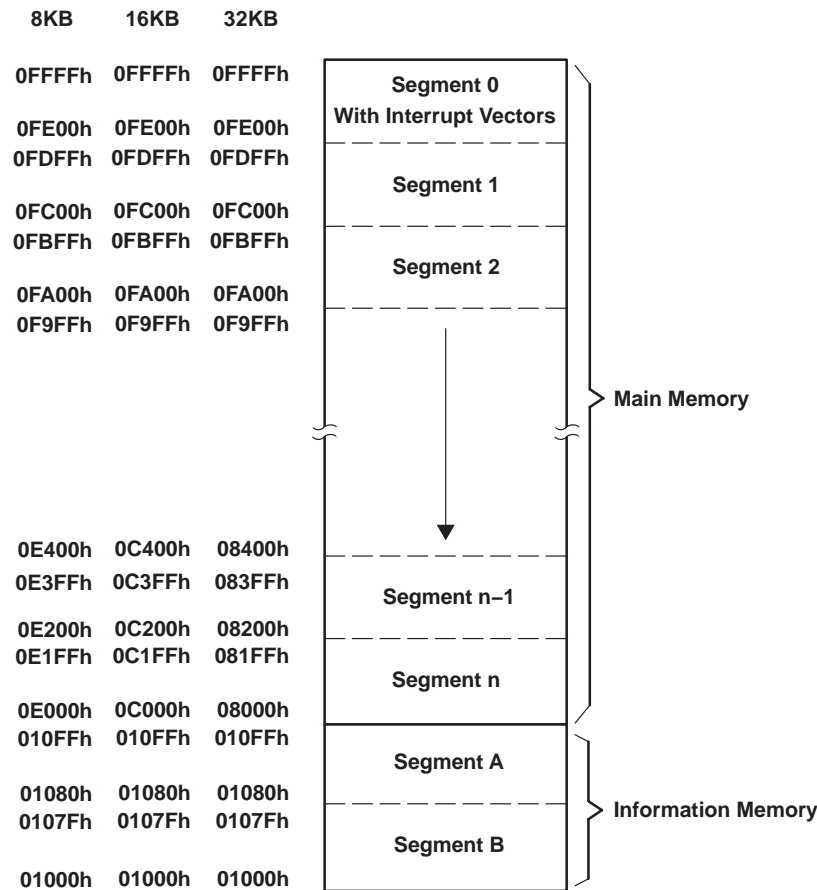

**peripherals**

Peripherals are connected to the CPU through data, address, and control busses and can be handled using all instructions. For complete module descriptions, refer to the *MSP430x4xx Family User's Guide*, literature number SLAU056.

**oscillator and system clock**

The clock system in the MSP430xW42x family of devices is supported by the FLL+ module that includes support for a 32768-Hz watch crystal oscillator, an internal digitally-controlled oscillator (DCO) and a high frequency crystal oscillator. The FLL+ clock module is designed to meet the requirements of both low system cost and low-power consumption. The FLL+ features a digital frequency locked loop (FLL) hardware which in conjunction with a digital modulator stabilizes the DCO frequency to a programmable multiple of the watch crystal frequency. The internal DCO provides a fast turn-on clock source and stabilizes in less than 6 μs. The FLL+ module provides the following clock signals:

- Auxiliary clock (ACLK), sourced from a 32768-Hz watch crystal or a high frequency crystal.
- Main clock (MCLK), the system clock used by the CPU.
- Sub-Main clock (SMCLK), the sub-system clock used by the peripheral modules.
- ACLK/n, the buffered output of ACLK, ACLK/2, ACLK/4, or ACLK/8.

# MSP430xW42x MIXED SIGNAL MICROCONTROLLER

SLAS383A – OCTOBER 2003 – REVISED AUGUST 2004

---

## **brownout, supply voltage supervisor**

The brownout circuit is implemented to provide the proper internal reset signal to the device during power on and power off. The supply voltage supervisor (SVS) circuitry detects if the supply voltage drops below a user selectable level and supports both supply voltage supervision (the device is automatically reset) and supply voltage monitoring (SVM, the device is not automatically reset).

The CPU begins code execution after the brownout circuit releases the device reset. However,  $V_{CC}$  may not have ramped to  $V_{CC(\min)}$  at that time. The user must insure the default FLL+ settings are not changed until  $V_{CC}$  reaches  $V_{CC(\min)}$ . If desired, the SVS circuit can be used to determine when  $V_{CC}$  reaches  $V_{CC(\min)}$ .

## **digital I/O**

There are six 8-bit I/O ports implemented—ports P1 through P6:

- All individual I/O bits are independently programmable.
- Any combination of input, output, and interrupt conditions is possible.
- Edge-selectable interrupt input capability for all the eight bits of ports P1 and P2.
- Read/write access to port-control registers is supported by all instructions.

## **Basic Timer1**

The Basic Timer1 has two independent 8-bit timers which can be cascaded to form a 16-bit timer/counter. Both timers can be read and written by software. The Basic Timer1 can be used to generate periodic interrupts and clock for the LCD module.

## **LCD drive**

The LCD driver generates the segment and common signals required to drive an LCD display. The LCD controller has dedicated data memory to hold segment drive information. Common and segment signals are generated as defined by the mode. Static, 2-MUX, 3-MUX, and 4-MUX LCDs are supported by this peripheral.

## **watchdog timer**

The primary function of the watchdog timer (WDT) module is to perform a controlled system restart after a software problem occurs. If the selected time interval expires, a system reset is generated. If the watchdog function is not needed in an application, the module can be configured as an interval timer and can generate interrupts at selected time intervals.

## **comparator\_A**

The primary function of the comparator\_A module is to support precision slope analog-to-digital conversions, battery-voltage supervision, and monitoring of external analog signals.

## **scan IF**

The scan interface is used to measure linear or rotational motion and supports LC and resistive sensors such as GMR sensors. The scan IF incorporates a  $V_{CC}/2$  generator, a comparator, and a 10-bit DAC and supports up to four sensors.



POST OFFICE BOX 655303 • DALLAS, TEXAS 75265

**timer0\_A3**

Timer0\_A3 is a 16-bit timer/counter with three capture/compare registers. Timer0\_A3 can support multiple capture/compares, PWM outputs, and interval timing. Timer0\_A3 also has extensive interrupt capabilities. Interrupts may be generated from the counter on overflow conditions and from each of the capture/compare registers.

Timer0_A3 Signal Connections					
Input Pin Number	Device Input Signal	Module Input Name	Module Block	Module Output Signal	Output Pin Number
48 - P1.5	TA0CLK	TACLK	Timer	NA	
	ACLK	ACLK			
	SMCLK	SMCLK			
48 - P1.5	$\overline{\text{TA0CLK}}$	INCLK			
53 - P1.0	TA0.0	CCI0A	CCR0	TA0.0	53 - P1.0
52 - P1.1	TA0.0	CCI0B			
	DVSS	GND			
	DVCC	VCC			
51 - P1.2	TA0.1	CCI1A	CCR1	TA0.1	51 - P1.2
	CAOUT (internal)	CCI1B			
	DVSS	GND			
	DVCC	VCC			
45 - P2.0	TA0.2	CCI2A	CCR2	TA0.2	45 - P2.0
	ACLK (internal)	CCI2B			
	DVSS	GND			
	DVCC	VCC			

# MSP430xW42x MIXED SIGNAL MICROCONTROLLER

SLAS383A – OCTOBER 2003 – REVISED AUGUST 2004

## timer1\_A5

Timer1\_A5 is a 16-bit timer/counter with five capture/compare registers. Timer1\_A5 can support multiple capture/compares, PWM outputs, and interval timing. Timer1\_A5 also has extensive interrupt capabilities. Interrupts may be generated from the counter on overflow conditions and from each of the capture/compare registers.

Timer1_A5 Signal Connections					
Input Pin Number	Device Input Signal	Module Input Name	Module Block	Module Output Signal	Output Pin Number
32 - P2.5	TA1CLK	TACLK	Timer	NA	
	ACLK	ACLK			
	SMCLK	SMCLK			
32 - P2.5	$\overline{\text{TA1CLK}}$	INCLK			
49 - P1.4	TA1.0	CCI0A	CCR0	TA1.0	49 - P1.4
50 - P1.3	TA1.0	CCI0B			
	DVSS	GND			
	DVCC	VCC			
44 - P2.1	TA1.1	CCI1A	CCR1	TA1.1	44 - P2.1
	CAOUT (internal)	CCI1B			
	DVSS	GND			
	DVCC	VCC			
35 - P2.2	TA1.2	CCI2A	CCR2	TA1.2	35 - P2.2
	SIFO0sig (internal)	CCI2B			
	DVSS	GND			
	DVCC	VCC			
34 - P2.3	TA1.3	CCI3A	CCR3	TA1.3	34 - P2.3
	SIFO1sig (internal)	CCI3B			
	DVSS	GND			
	DVCC	VCC			
33 - P2.4	TA1.4	CCI4A	CCR4	TA1.4	33 - P2.4
	SIFO2sig (internal)	CCI4B			
	DVSS	GND			
	DVCC	VCC			

**peripheral file map**

<b>PERIPHERALS WITH WORD ACCESS</b>			
<b>Watchdog</b>	Watchdog Timer control	WDTCTL	0120h
<b>Timer1_A5</b>	Timer1_A interrupt vector	TA1IV	011Eh
	Timer1_A control	TA1CTL	0180h
	Capture/compare control 0	TA1CCTL0	0182h
	Capture/compare control 1	TA1CCTL1	0184h
	Capture/compare control 2	TA1CCTL2	0186h
	Capture/compare control 3	TA1CCTL3	0188h
	Capture/compare control 4	TA1CCTL4	018Ah
	Reserved		018Ch
	Reserved		018Eh
	Timer1_A register	TA1R	0190h
	Capture/compare register 0	TA1CCR0	0192h
	Capture/compare register 1	TA1CCR1	0194h
	Capture/compare register 2	TA1CCR2	0196h
	Capture/compare register 3	TA1CCR3	0198h
	Capture/compare register 4	TA1CCR4	019Ah
	Reserved		019Ch
	Reserved		019Eh
<b>Timer0_A3</b>	Timer0_A interrupt vector	TA0IV	012Eh
	Timer0_A control	TA0CTL0	0160h
	Capture/compare control 0	TA0CCTL0	0162h
	Capture/compare control 1	TA0CCTL1	0164h
	Capture/compare control 2	TA0CCTL2	0166h
	Reserved		0168h
	Reserved		016Ah
	Reserved		016Ch
	Reserved		016Eh
	Timer0_A register	TA0R	0170h
	Capture/compare register 0	TA0CCR0	0172h
	Capture/compare register 1	TA0CCR1	0174h
	Capture/compare register 2	TA0CCR2	0176h
	Reserved		0178h
	Reserved		017Ah
	Reserved		017Ch
	Reserved		017Eh
<b>Flash</b>	Flash control 3	FCTL3	012Ch
	Flash control 2	FCTL2	012Ah
	Flash control 1	FCTL1	0128h

# MSP430xW42x MIXED SIGNAL MICROCONTROLLER

SLAS383A – OCTOBER 2003 – REVISED AUGUST 2004

PERIPHERALS WITH WORD ACCESS (CONTINUED)			
<b>Scan IF</b>	SIF timing state machine 23	SIFTSM23	01FEh
	:	:	:
	SIF timing state machine 0	SIFTSM0	01D0h
	SIF DAC register 7	SIFDACR7	01CEh
	:	:	:
	SIF DAC register 0	SIFDACR0	01C0h
	SIF control register 5	SIFCTL5	01BEh
	SIF control register 4	SIFCTL4	01BCh
	SIF control register 3	SIFCTL3	01BAh
	SIF control register 2	SIFCTL2	01B8h
	SIF control register 1	SIFCTL1	01B6h
	SIF processing state machine vector	SIFPSMV	01B4h
	SIF counter CNT1/2	SIFCNT	01B2h
	Reserved	SIFDEBUG	01B0h
PERIPHERALS WITH BYTE ACCESS			
<b>LCD</b>	LCD memory 20	LCDM20	0A4h
	:	:	:
	LCD memory 16	LCDM16	0A0h
	LCD memory 15	LCDM15	09Fh
	:	:	:
	LCD memory 1	LCDM1	091h
	LCD control and mode	LCDCTL	090h
<b>Comparator_A</b>	Comparator_A port disable	CAPD	05Bh
	Comparator_A control 2	CACTL2	05Ah
	Comparator_A control 1	CACTL1	059h
<b>Brownout, SVS</b>	SVS control register	SVSCTL	056h
<b>FLL+ Clock</b>	FLL+ Control 1	FLL_CTL1	054h
	FLL+ Control 0	FLL_CTL0	053h
	System clock frequency control	SCFQCTL	052h
	System clock frequency integrator	SCFI1	051h
	System clock frequency integrator	SCFI0	050h
<b>Basic Timer1</b>	BT counter 2	BTCNT2	047h
	BT counter 1	BTCNT1	046h
	BT control	BTCTL	040h



**peripheral file map (continued)**

<b>PERIPHERALS WITH BYTE ACCESS (CONTINUED)</b>			
<b>Port P6</b>	Port P6 selection	P6SEL	037h
	Port P6 direction	P6DIR	036h
	Port P6 output	P6OUT	035h
	Port P6 input	P6IN	034h
<b>Port P5</b>	Port P5 selection	P5SEL	033h
	Port P5 direction	P5DIR	032h
	Port P5 output	P5OUT	031h
	Port P5 input	P5IN	030h
<b>Port P4</b>	Port P4 selection	P4SEL	01Fh
	Port P4 direction	P4DIR	01Eh
	Port P4 output	P4OUT	01Dh
	Port P4 input	P4IN	01Ch
<b>Port P3</b>	Port P3 selection	P3SEL	01Bh
	Port P3 direction	P3DIR	01Ah
	Port P3 output	P3OUT	019h
	Port P3 input	P3IN	018h
<b>Port P2</b>	Port P2 selection	P2SEL	02Eh
	Port P2 interrupt enable	P2IE	02Dh
	Port P2 interrupt-edge select	P2IES	02Ch
	Port P2 interrupt flag	P2IFG	02Bh
	Port P2 direction	P2DIR	02Ah
	Port P2 output	P2OUT	029h
	Port P2 input	P2IN	028h
<b>Port P1</b>	Port P1 selection	P1SEL	026h
	Port P1 interrupt enable	P1IE	025h
	Port P1 interrupt-edge select	P1IES	024h
	Port P1 interrupt flag	P1IFG	023h
	Port P1 direction	P1DIR	022h
	Port P1 output	P1OUT	021h
	Port P1 input	P1IN	020h
<b>Special Functions</b>	SFR module enable 2	ME2	005h
	SFR module enable 1	ME1	004h
	SFR interrupt flag 2	IFG2	003h
	SFR interrupt flag 1	IFG1	002h
	SFR interrupt enable 2	IE2	001h
	SFR interrupt enable 1	IE1	000h

**absolute maximum ratings†**

Voltage applied at $V_{CC}$ to $V_{SS}$ .....	-0.3 V to + 4.1 V
Voltage applied to any pin (see Note) .....	-0.3 V to $V_{CC} + 0.3$ V
Diode current at any device terminal . . . . .	$\pm 2$ mA
Storage temperature (unprogrammed device) .....	-55°C to 150°C
Storage temperature (programmed device) .....	-40°C to 85°C

† Stresses beyond those listed under “absolute maximum ratings” may cause permanent damage to the device. These are stress ratings only, and functional operation of the device at these or any other conditions beyond those indicated under “recommended operating conditions” is not implied. Exposure to absolute-maximum-rated conditions for extended periods may affect device reliability.

NOTE: All voltages referenced to  $V_{SS}$ . The JTAG fuse-blow voltage,  $V_{FB}$ , is allowed to exceed the absolute maximum rating. The voltage is applied to the TDI/TCLK pin when blowing the JTAG fuse.



# MSP430xW42x MIXED SIGNAL MICROCONTROLLER

SLAS383A – OCTOBER 2003 – REVISED AUGUST 2004

## recommended operating conditions

PARAMETER		MIN	NOM	MAX	UNITS	
Supply voltage during program execution, SVS disabled $V_{CC}$ ( $AV_{CC} = DV_{CC} = V_{CC}$ )	MSP430xW42x	1.8		3.6	V	
Supply voltage during program execution, SVS enabled (see Note 1), $V_{CC}$ ( $AV_{CC} = DV_{CC} = V_{CC}$ )	MSP430xW42x	2.2		3.6	V	
Supply voltage during programming flash memory, $V_{CC}$ ( $AV_{CC} = DV_{CC} = V_{CC}$ )	MSP430FW42x	2.7		3.6	V	
Supply voltage, $V_{SS}$ ( $AV_{SS} = DV_{SS} = V_{SS}$ )		0		0	V	
Operating free-air temperature range, $T_A$	MSP430xW42x	-40		85	°C	
LFXT1 crystal frequency, $f_{(LFXT1)}$ (see Note 2)	LF selected, XTS_FLL=0	Watch crystal		32768	Hz	
	XT1 selected, XTS_FLL=1	Ceramic resonator		450	8000	kHz
	XT1 selected, XTS_FLL=1	Crystal		1000	8000	kHz
Processor frequency (signal MCLK), $f_{(System)}$	$V_{CC} = 1.8$ V	DC		4.15	MHz	
	$V_{CC} = 3.6$ V	DC		8		

NOTES: 1. The minimum operating supply voltage is defined according to the trip point where POR is going active by decreasing supply voltage. POR is going inactive when the supply voltage is raised above minimum supply voltage plus the hysteresis of the SVS circuitry.  
2. In LF mode, the LFXT1 oscillator requires a watch crystal. In XT1 mode, LFXT1 accepts a ceramic resonator or a crystal.

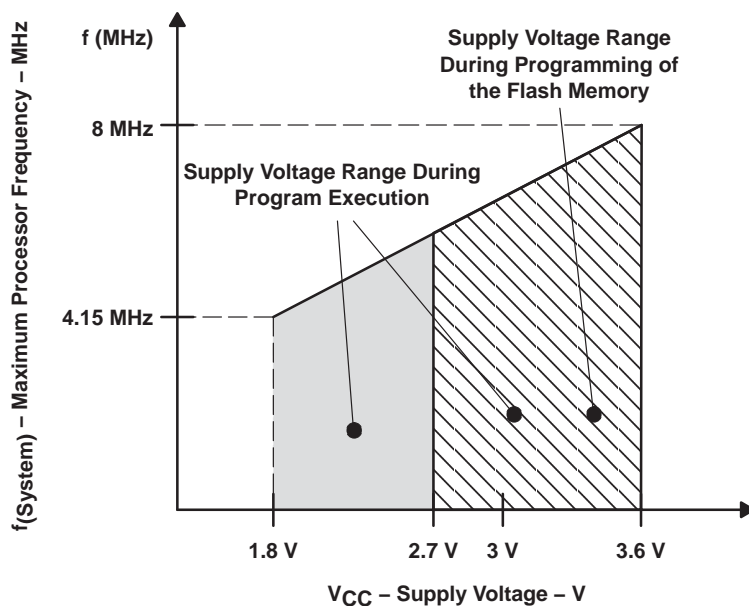

Figure 1. Maximum Frequency vs Supply Voltage

**electrical characteristics over recommended operating free-air temperature (unless otherwise noted)**

**supply current into AV<sub>CC</sub> + DV<sub>CC</sub> excluding external current, (see Note 1)**

PARAMETER		TEST CONDITIONS		MIN	NOM	MAX	UNIT	
I <sub>(AM)</sub>	Active mode, f <sub>(MCLK)</sub> = f <sub>(SMCLK)</sub> = 1 MHz, f <sub>(ACLK)</sub> = 32,768 Hz, XTS_FLL = 0 (FW42x: Program executes in flash)	T <sub>A</sub> = -40°C to 85°C	V <sub>CC</sub> = 2.2 V	200	250	μA		
			V <sub>CC</sub> = 3 V	300	350			
I <sub>(LPM0)</sub>	Low-power mode, (LPM0) f <sub>(MCLK)</sub> = f <sub>(SMCLK)</sub> = 1 MHz, f <sub>(ACLK)</sub> = 32,768 Hz, XTS_FLL = 0 FN_8=FN_4=FN_3=FN_2=0	T <sub>A</sub> = -40°C to 85°C	V <sub>CC</sub> = 2.2 V	57	70	μA		
			V <sub>CC</sub> = 3 V	92	100			
I <sub>(LPM2)</sub>	Low-power mode, (LPM2)	T <sub>A</sub> = -40°C to 85°C	V <sub>CC</sub> = 2.2 V	11	14	μA		
			V <sub>CC</sub> = 3 V	17	22			
I <sub>(LPM3)</sub>	Low-power mode, (LPM3) (see Note 2)	T <sub>A</sub> = -40°C to 85°C	V <sub>CC</sub> = 2.2 V	T <sub>A</sub> = -40°C	0.95	1.4	μA	
				T <sub>A</sub> = -10°C	0.8	1.3		
				T <sub>A</sub> = 25°C	0.7	1.2		
				T <sub>A</sub> = 60°C	0.95	1.4		
				T <sub>A</sub> = 85°C	1.6	2.3		
		T <sub>A</sub> = -40°C to 85°C		V <sub>CC</sub> = 3 V	T <sub>A</sub> = -40°C	1.1		1.7
					T <sub>A</sub> = -10°C	1.0		1.6
					T <sub>A</sub> = 25°C	0.9		1.5
					T <sub>A</sub> = 60°C	1.1		1.7
					T <sub>A</sub> = 85°C	2.0		2.6
I <sub>(LPM4)</sub>	Low-power mode, (LPM4)	T <sub>A</sub> = -40°C to 85°C	V <sub>CC</sub> = 2.2 V/3 V		T <sub>A</sub> = -40°C	0.1	0.5	μA
					T <sub>A</sub> = 25°C	0.1	0.5	
					T <sub>A</sub> = 85°C	0.8	2.5	

NOTES: 1. All inputs are tied to 0 V or V<sub>CC</sub>. Outputs do not source or sink any current. The current consumption is measured with active Basic Timer1 and LCD (ACLK selected).

The current consumption of the Comparator\_A and the SVS module are specified in the respective sections.

2. The LPM3 currents are characterized with a KDS Daishinku DT-38 (6 pF) crystal.

**current consumption of active mode versus system frequency, F version**

$$I_{(AM)} = I_{(AM)} [1 \text{ MHz}] \times f_{(\text{System})} [\text{MHz}]$$

**current consumption of active mode versus supply voltage, F version**

$$I_{(AM)} = I_{(AM)} [3 \text{ V}] + 140 \mu\text{A/V} \times (V_{\text{CC}} - 3 \text{ V})$$

# MSP430xW42x MIXED SIGNAL MICROCONTROLLER

SLAS383A – OCTOBER 2003 – REVISED AUGUST 2004

electrical characteristics over recommended operating free-air temperature (unless otherwise noted) (continued)

## Schmitt-trigger inputs – Ports P1, P2, P3, P4, P5, and P6; $\overline{\text{RST}}/\text{NMI}$ ; JTAG: TCK, TMS, TDI/TCLK

PARAMETER		TEST CONDITIONS	MIN	TYP	MAX	UNIT
V <sub>IT+</sub>	Positive-going input threshold voltage	V <sub>CC</sub> = 2.2 V	1.1		1.5	V
		V <sub>CC</sub> = 3 V	1.5		1.9	
V <sub>IT-</sub>	Negative-going input threshold voltage	V <sub>CC</sub> = 2.2 V	0.4		0.9	V
		V <sub>CC</sub> = 3 V	0.9		1.3	
V <sub>hys</sub>	Input voltage hysteresis (V <sub>IT+</sub> – V <sub>IT-</sub> )	V <sub>CC</sub> = 2.2 V	0.3		1.1	V
		V <sub>CC</sub> = 3 V	0.45		1	

## inputs P<sub>x.x</sub>, T<sub>Ax.x</sub>

PARAMETER		TEST CONDITIONS	V <sub>CC</sub>	MIN	TYP	MAX	UNIT
t <sub>(int)</sub>	External interrupt timing	Port P1, P2: P1.x to P2.x, External trigger signal for the interrupt flag, (see Note 1)	2.2 V/3 V	1.5			cycle
			2.2 V	62			ns
			3 V	50			
t <sub>(cap)</sub>	Timer_A, capture timing	T <sub>Ax.x</sub>	2.2 V	62			ns
			3 V	50			
f <sub>(TAext)</sub>	Timer_A clock frequency externally applied to pin	T <sub>Ax</sub> CLK, INCLK t <sub>(H)</sub> = t <sub>(L)</sub>	2.2 V			8	MHz
			3 V			10	
f <sub>(TAint)</sub>	Timer_A clock frequency	SMCLK or ACLK signal selected	2.2 V			8	MHz
			3 V			10	

NOTES: 1. The external signal sets the interrupt flag every time the minimum t<sub>(int)</sub> cycle and time parameters are met. It may be set even with trigger signals shorter than t<sub>(int)</sub>. Both the cycle and timing specifications must be met to ensure the flag is set. t<sub>(int)</sub> is measured in MCLK cycles.

## leakage current (see Note 1)

PARAMETER			TEST CONDITIONS		MIN	NOM	MAX	UNIT
I <sub>lkg</sub> (P1.x)	Leakage current	Port P1	Port 1: V <sub>(P1.x)</sub> (see Note 2)	V <sub>CC</sub> = 2.2 V/3 V			±50	nA
I <sub>lkg</sub> (P6.x)	Leakage current	Port P6	Port 6: V <sub>(P6.x)</sub> (see Note 2)	V <sub>CC</sub> = 2.2 V/3 V			±50	nA

NOTES: 1. The leakage current is measured with V<sub>SS</sub> or V<sub>CC</sub> applied to the corresponding pin(s), unless otherwise noted.  
2. The port pin must be selected as an input.



**electrical characteristics over recommended operating free-air temperature (unless otherwise noted) (continued)**

**outputs – Ports P1, P2, P3, P4, P5, and P6**

PARAMETER		TEST CONDITIONS	MIN	TYP	MAX	UNIT
V <sub>OH</sub>	High-level output voltage	I <sub>OH(max)</sub> = -1.5 mA, V <sub>CC</sub> = 2.2 V, See Note 1	V <sub>CC</sub> -0.25		V <sub>CC</sub>	V
		I <sub>OH(max)</sub> = -6 mA, V <sub>CC</sub> = 2.2 V, See Note 2	V <sub>CC</sub> -0.6		V <sub>CC</sub>	
		I <sub>OH(max)</sub> = -1.5 mA, V <sub>CC</sub> = 3 V, See Note 1	V <sub>CC</sub> -0.25		V <sub>CC</sub>	
		I <sub>OH(max)</sub> = -6 mA, V <sub>CC</sub> = 3 V, See Note 2	V <sub>CC</sub> -0.6		V <sub>CC</sub>	
V <sub>OL</sub>	Low-level output voltage	I <sub>OL(max)</sub> = 1.5 mA, V <sub>CC</sub> = 2.2 V, See Note 1	V <sub>SS</sub>	V <sub>SS</sub> +0.25	V	
		I <sub>OL(max)</sub> = 6 mA, V <sub>CC</sub> = 2.2 V, See Note 2	V <sub>SS</sub>	V <sub>SS</sub> +0.6		
		I <sub>OL(max)</sub> = 1.5 mA, V <sub>CC</sub> = 3 V, See Note 1	V <sub>SS</sub>	V <sub>SS</sub> +0.25		
		I <sub>OL(max)</sub> = 6 mA, V <sub>CC</sub> = 3 V, See Note 2	V <sub>SS</sub>	V <sub>SS</sub> +0.6		

- NOTES: 1. The maximum total current, I<sub>OH(max)</sub> and I<sub>OL(max)</sub>, for all outputs combined, should not exceed ±12 mA to satisfy the maximum specified voltage drop.  
 2. The maximum total current, I<sub>OH(max)</sub> and I<sub>OL(max)</sub>, for all outputs combined, should not exceed ±24 mA to satisfy the maximum specified voltage drop.

**output frequency**

PARAMETER		TEST CONDITIONS	MIN	TYP	MAX	UNIT
f <sub>Px.y</sub>	(1 ≤ x ≤ 6, 0 ≤ y ≤ 7)	C <sub>L</sub> = 20 pF, I <sub>L</sub> = ± 1.5mA	V <sub>CC</sub> = 2.2 V	DC	10	MHz
			V <sub>CC</sub> = 3 V	DC	12	
f <sub>ACLK</sub> , f <sub>MCLK</sub> , f <sub>SMCLK</sub>	P1.1/TA0.0/MCLK, P1.5/TA0CLK/ACLK	C <sub>L</sub> = 20 pF	V <sub>CC</sub> = 2.2 V		8	MHz
			V <sub>CC</sub> = 3 V		12	
t <sub>Xdc</sub>	Duty cycle of output frequency	P1.5/TA0CLK/ACLK, C <sub>L</sub> = 20 pF V <sub>CC</sub> = 2.2 V / 3 V	f <sub>ACLK</sub> = f <sub>LFXT1</sub> = f <sub>XT1</sub>	40%	60%	
			f <sub>ACLK</sub> = f <sub>LFXT1</sub> = f <sub>LF</sub>	30%	70%	
			f <sub>ACLK</sub> = f <sub>LFXT1</sub> /n	50%		
		P1.1/TA0.0/MCLK, C <sub>L</sub> = 20 pF, V <sub>CC</sub> = 2.2 V / 3 V	f <sub>MCLK</sub> = f <sub>LFXT1</sub> /n	50%– 15 ns	50%	50%+ 15 ns
f <sub>MCLK</sub> = f <sub>DCOCLK</sub>	50%– 15 ns		50%	50%+ 15 ns		

# MSP430xW42x MIXED SIGNAL MICROCONTROLLER

SLAS383A – OCTOBER 2003 – REVISED AUGUST 2004

electrical characteristics over recommended operating free-air temperature (unless otherwise noted) (continued)

outputs – Ports P1, P2, P3, P4, P5, and P6 (continued)

TYPICAL LOW-LEVEL OUTPUT CURRENT  
vs  
LOW-LEVEL OUTPUT VOLTAGE

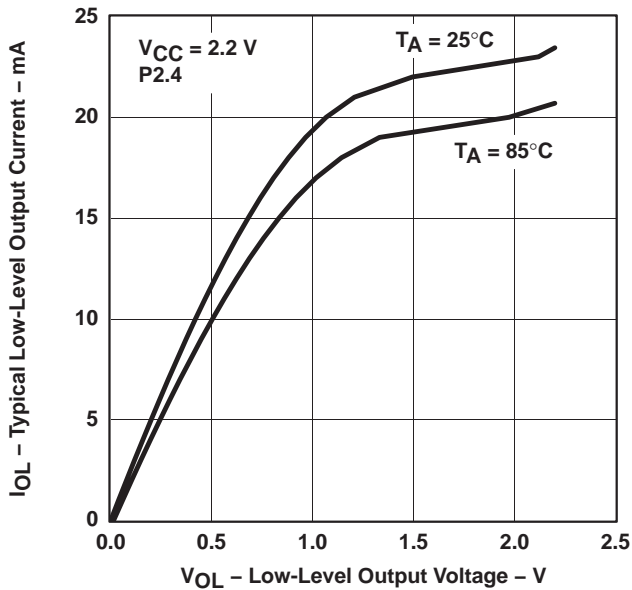

Figure 2

TYPICAL LOW-LEVEL OUTPUT CURRENT  
vs  
LOW-LEVEL OUTPUT VOLTAGE

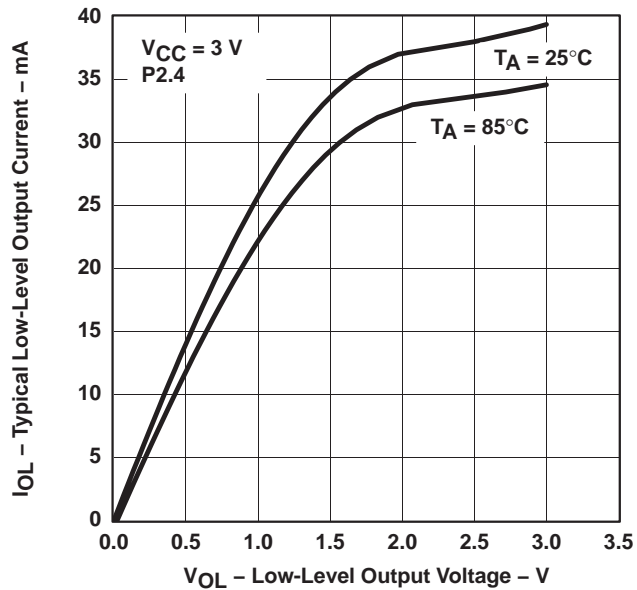

Figure 3

TYPICAL HIGH-LEVEL OUTPUT CURRENT  
vs  
HIGH-LEVEL OUTPUT VOLTAGE

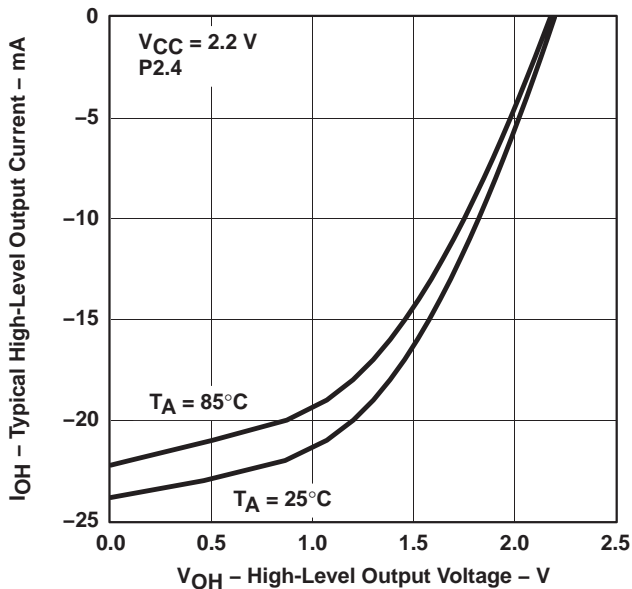

Figure 4

TYPICAL HIGH-LEVEL OUTPUT CURRENT  
vs  
HIGH-LEVEL OUTPUT VOLTAGE

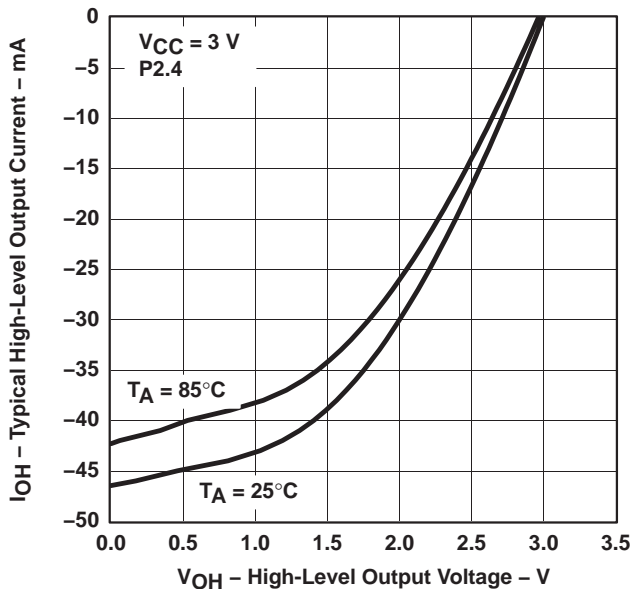

Figure 5

NOTE: One output loaded at a time



**electrical characteristics over recommended operating free-air temperature (unless otherwise noted) (continued)**

**wake-up LPM3**

PARAMETER		TEST CONDITIONS	MIN	TYP	MAX	UNIT
$t_{d(LPM3)}$ Delay time		f = 1 MHz			6	$\mu\text{s}$
		f = 2 MHz	$V_{CC} = 2.2 \text{ V}/3 \text{ V}$		6	
		f = 3 MHz			6	

**RAM (see Note 1)**

PARAMETER	TEST CONDITIONS	MIN	TYP	MAX	UNIT
$V_{RAMh}$	CPU halted (see Note 1)	1.6			V

NOTES: 1. This parameter defines the minimum supply voltage when the data in the program memory RAM remain unchanged. No program execution should take place during this supply voltage condition.

**LCD**

PARAMETER		TEST CONDITIONS		MIN	TYP	MAX	UNIT
$V_{(33)}$	Analog voltage	Voltage at P5.7/R33	$V_{CC} = 3 \text{ V}$	2.5		$V_{CC} + 0.2$	V
$V_{(23)}$		Voltage at P5.6/R23		$(V_{33} - V_{03}) \times 2/3 + V_{03}$			
$V_{(13)}$		Voltage at P5.5/R13		$(V_{(33)} - V_{(03)}) \times 1/3 + V_{(03)}$			
$V_{(33)} - V_{(03)}$		Voltage at R33/R03		2.5	$V_{CC} + 0.2$		
$I_{(R03)}$	Input leakage	$R03 = V_{SS}$	No load at all segment and common lines, $V_{CC} = 3 \text{ V}$			$\pm 20$	nA
$I_{(R13)}$		$P5.5/R13 = V_{CC}/3$				$\pm 20$	
$I_{(R23)}$		$P5.6/R23 = 2 \times V_{CC}/3$				$\pm 20$	
$V_{(Sxx0)}$	Segment line voltage	$I_{(Sxx)} = -3 \mu\text{A}$ , $V_{CC} = 3 \text{ V}$	$V_{CC} = 3 \text{ V}$	$V_{(03)}$		$V_{(03)} - 0.1$	V
$V_{(Sxx1)}$				$V_{(13)}$		$V_{(13)} - 0.1$	
$V_{(Sxx2)}$				$V_{(23)}$		$V_{(23)} - 0.1$	
$V_{(Sxx3)}$				$V_{(33)}$		$V_{(33)} + 0.1$	

# MSP430xW42x MIXED SIGNAL MICROCONTROLLER

SLAS383A – OCTOBER 2003 – REVISED AUGUST 2004

## electrical characteristics over recommended operating free-air temperature (unless otherwise noted) (continued)

### Comparator\_A (see Note 1)

PARAMETER	TEST CONDITIONS	MIN	TYP	MAX	UNIT	
I(CC)	CAON = 1, CARSEL = 0, CAREF = 0	V <sub>CC</sub> = 2.2 V	25	40	μA	
		V <sub>CC</sub> = 3 V	45	60		
I(Refladder/RefDiode)	CAON = 1, CARSEL = 0, CAREF = 1/2/3, No load at P1.6/CA0 and P1.7/CA1	V <sub>CC</sub> = 2.2 V	30	50	μA	
		V <sub>CC</sub> = 3 V	45	71		
V(Ref025)	$\frac{\text{Voltage @ } 0.25 V_{CC} \text{ node}}{V_{CC}}$ PCA0 = 1, CARSEL = 1, CAREF = 1, No load at P1.6/CA0 and P1.7/CA1	V <sub>CC</sub> = 2.2 V / 3 V	0.23	0.24	0.25	
V(Ref050)	$\frac{\text{Voltage @ } 0.5 V_{CC} \text{ node}}{V_{CC}}$ PCA0 = 1, CARSEL = 1, CAREF = 2, No load at P1.6/CA0 and P1.7/CA1	V <sub>CC</sub> = 2.2V / 3 V	0.47	0.48	0.50	
V(RefVT)	(See Figure 6 and Figure 7) PCA0 = 1, CARSEL = 1, CAREF = 3, No load at P1.6/CA0 and P1.7/CA1; T <sub>A</sub> = 85°C	V <sub>CC</sub> = 2.2 V	390	480	540	mV
		V <sub>CC</sub> = 3.0 V	400	490	550	
V(IC)	Common-mode input voltage range CAON = 1	V <sub>CC</sub> = 2.2V/3 V	0	V <sub>CC</sub> -1.0	V	
V(offset)	Offset voltage See Note 2	V <sub>CC</sub> = 2.2 V/3 V	-30	30	mV	
Vhys	Input hysteresis CAON = 1	V <sub>CC</sub> = 2.2 V / 3 V	0	0.7	1.4	mV
t(response LH)	T <sub>A</sub> = 25°C, Overdrive 10 mV, without filter: CAF = 0	V <sub>CC</sub> = 2.2 V	130	210	300	ns
		V <sub>CC</sub> = 3 V	80	150	240	
	T <sub>A</sub> = 25°C Overdrive 10 mV, with filter: CAF = 1	V <sub>CC</sub> = 2.2 V	1.4	1.9	3.4	μs
		V <sub>CC</sub> = 3 V	0.9	1.5	2.6	
t(response HL)	T <sub>A</sub> = 25°C Overdrive 10 mV, without filter: CAF = 0	V <sub>CC</sub> = 2.2 V	130	210	300	ns
		V <sub>CC</sub> = 3 V	80	150	240	
	T <sub>A</sub> = 25°C, Overdrive 10 mV, with filter: CAF = 1	V <sub>CC</sub> = 2.2 V	1.4	1.9	3.4	μs
		V <sub>CC</sub> = 3.0 V	0.9	1.5	2.6	

- NOTES: 1. The leakage current for the Comparator\_A terminals is identical to I<sub>kg</sub>(P<sub>x,x</sub>) specification.  
 2. The input offset voltage can be cancelled by using the CAEX bit to invert the Comparator\_A inputs on successive measurements. The two successive measurements are then summed together.



electrical characteristics over recommended operating free-air temperature (unless otherwise noted) (continued)

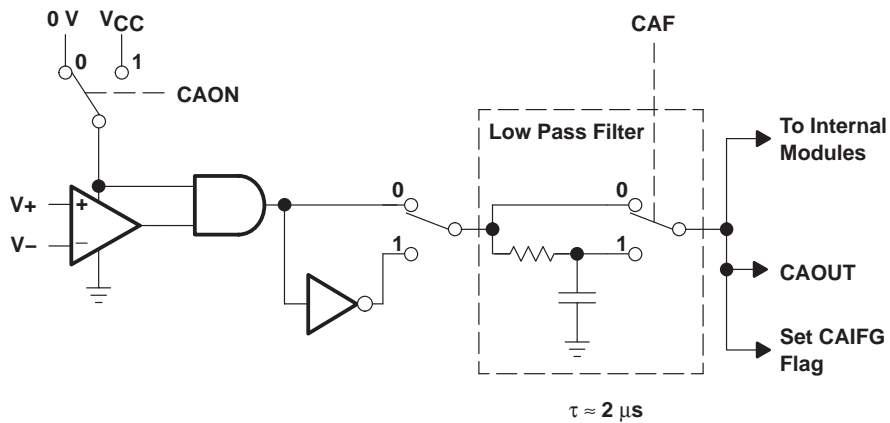
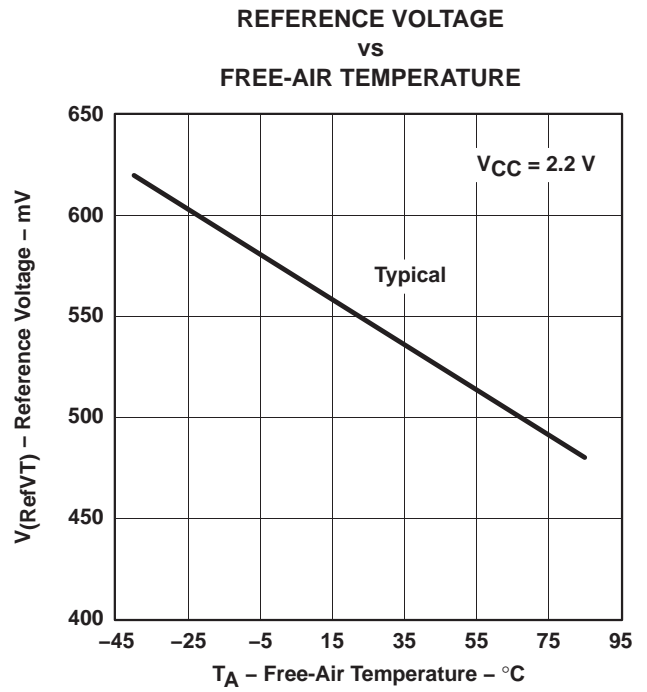
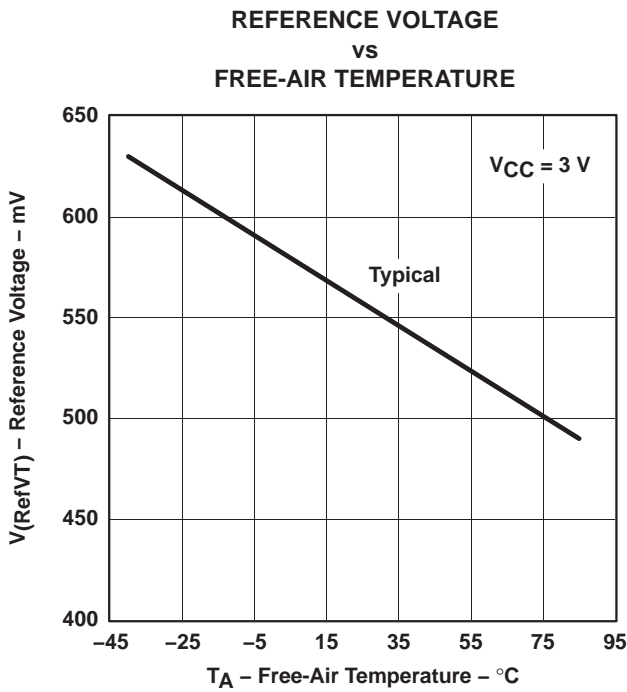

**Figure 8. Block Diagram of Comparator\_A Module**

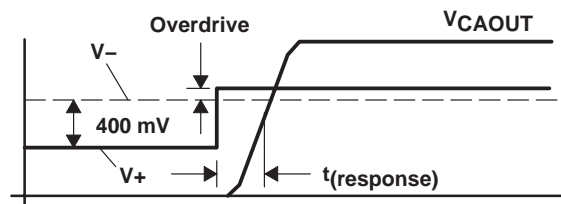

# MSP430xW42x MIXED SIGNAL MICROCONTROLLER

SLAS383A – OCTOBER 2003 – REVISED AUGUST 2004

electrical characteristics over recommended operating free-air temperature (unless otherwise noted) (continued)

## POR brownout, reset (see Notes 1 and 2)

PARAMETER	TEST CONDITIONS	MIN	TYP	MAX	UNIT
$t_d(\text{BOR})$				2000	$\mu\text{s}$
$V_{\text{CC}}(\text{start})$	$dV_{\text{CC}}/dt \leq 3 \text{ V/s}$ (see Figure 10)		$0.7 \times V(\text{B\_IT-})$		V
$V(\text{B\_IT-})$	$dV_{\text{CC}}/dt \leq 3 \text{ V/s}$ (see Figure 10, Figure 11, Figure 12)			1.71	V
$V_{\text{hys}}(\text{B\_IT-})$	$dV_{\text{CC}}/dt \leq 3 \text{ V/s}$ (see Figure 10)	70	130	180	mV
$t(\text{reset})$	Pulse length needed at $\overline{\text{RST/NMI}}$ pin to accepted reset internally, $V_{\text{CC}} = 2.2 \text{ V}/3 \text{ V}$	2			$\mu\text{s}$

- NOTES: 1. The current consumption of the brownout module is already included in the  $I_{\text{CC}}$  current consumption data. The voltage level  $V(\text{B\_IT-}) + V_{\text{hys}}(\text{B\_IT-})$  is  $\leq 1.8 \text{ V}$ .
2. During power up, the CPU begins code execution following a period of  $t_d(\text{BOR})$  after  $V_{\text{CC}} = V(\text{B\_IT-}) + V_{\text{hys}}(\text{B\_IT-})$ . The default FLL+ settings must not be changed until  $V_{\text{CC}} \geq V_{\text{CC}}(\text{min})$ , where  $V_{\text{CC}}(\text{min})$  is the minimum supply voltage for the desired operating frequency. See the *MSP430x4xx Family User's Guide* (SLAU056) for more information on the brownout/SVS circuit.

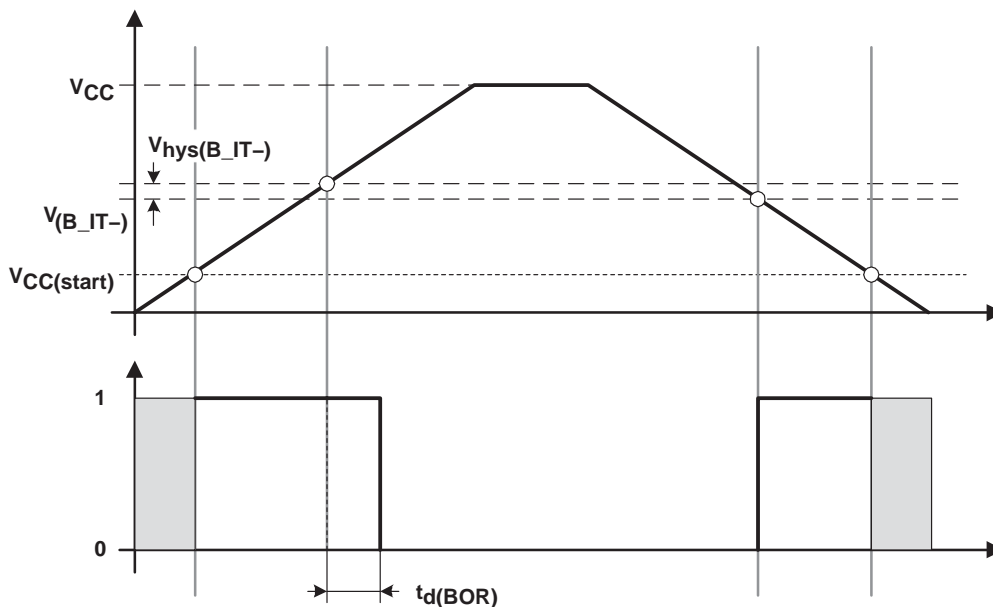

Figure 10. POR/Brownout Reset (BOR) vs Supply Voltage

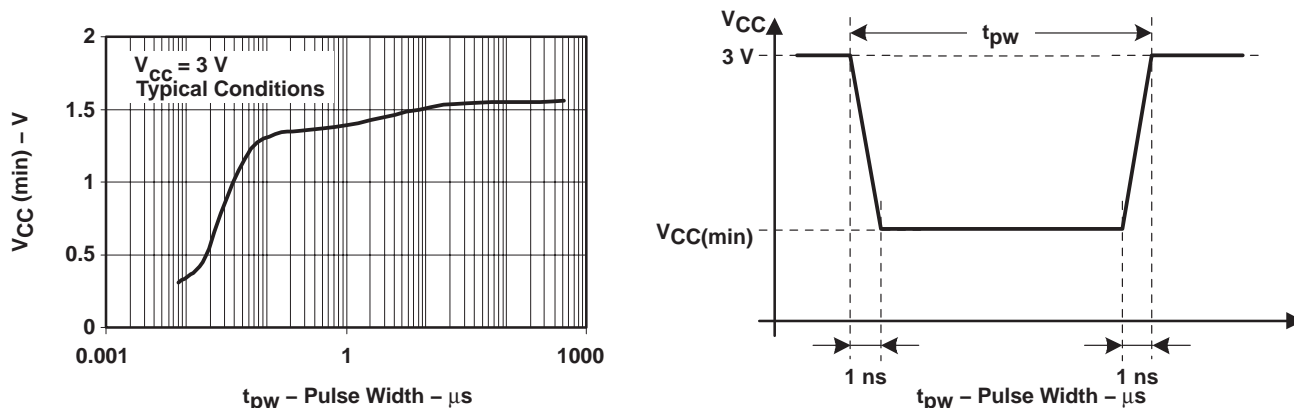

Figure 11.  $V_{\text{CC}}(\text{min})$  Level With a Square Voltage Drop to Generate a POR/Brownout Signal



electrical characteristics over recommended operating free-air temperature (unless otherwise noted) (continued)

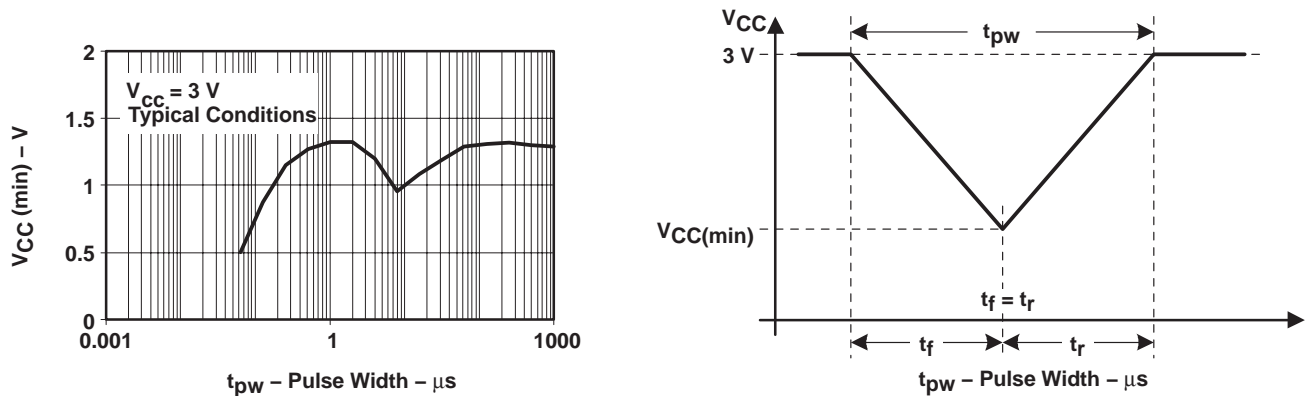

Figure 12.  $V_{CC(min)}$  Level With a Triangle Voltage Drop to Generate a POR/Brownout Signal

SVS (supply voltage supervisor/monitor) (See Notes 1 and 2)

PARAMETER	TEST CONDITIONS	MIN	NOM	MAX	UNIT	
$t_d(SVSR)$	$dV_{CC}/dt > 30 \text{ V/ms}$ (see Figure 13)	5		150	$\mu\text{s}$	
	$dV_{CC}/dt \leq 30 \text{ V/ms}$			2000	$\mu\text{s}$	
$t_d(SVSON)$	SVSON, switch from VLD=0 to VLD $\neq$ 0, $V_{CC} = 3 \text{ V}$	20		150	$\mu\text{s}$	
$t_{settle}$	VLD $\neq$ 0 <sup>†</sup>			12	$\mu\text{s}$	
$V(SVStart)$	VLD $\neq$ 0, $V_{CC}/dt \leq 3 \text{ V/s}$ (see Figure 13)		1.55	1.7	V	
$V_{hys}(SVS\_IT-)$	$V_{CC}/dt \leq 3 \text{ V/s}$ (see Figure 13)	VLD = 1	70	120	155	mV
		VLD = 2 .. 14	$V(SVS\_IT-) \times 0.004$		$V(SVS\_IT-) \times 0.008$	
$V(SVS\_IT-)$	$V_{CC}/dt \leq 3 \text{ V/s}$ (see Figure 13), external voltage applied on SVSIN	VLD = 15	4.4		10.4	mV
		VLD = 1	1.8	1.9	2.05	V
		VLD = 2	1.94	2.1	2.25	
		VLD = 3	2.05	2.2	2.37	
		VLD = 4	2.14	2.3	2.48	
		VLD = 5	2.24	2.4	2.6	
		VLD = 6	2.33	2.5	2.71	
		VLD = 7	2.46	2.65	2.86	
		VLD = 8	2.58	2.8	3	
		VLD = 9	2.69	2.9	3.13	
		VLD = 10	2.83	3.05	3.29	
		VLD = 11	2.94	3.2	3.42	
		VLD = 12	3.11	3.35	3.61 <sup>†</sup>	
	VLD = 13	3.24	3.5	3.76 <sup>†</sup>		
VLD = 14	3.43	3.7 <sup>†</sup>	3.99 <sup>†</sup>			
$I_{CC}(SVS)$ (see Note 1)	VLD $\neq$ 0, $V_{CC} = 2.2 \text{ V}/3 \text{ V}$		10	15	$\mu\text{A}$	

<sup>†</sup> The recommended operating voltage range is limited to 3.6 V.

<sup>‡</sup>  $t_{settle}$  is the settling time that the comparator o/p needs to have a stable level after VLD is switched VLD  $\neq$  0 to a different VLD value somewhere between 2 and 15. The overdrive is assumed to be  $> 50 \text{ mV}$ .

- NOTES: 1. The current consumption of the SVS module is not included in the  $I_{CC}$  current consumption data.  
2. The SVS is not active at power up.

# MSP430xW42x MIXED SIGNAL MICROCONTROLLER

SLAS383A – OCTOBER 2003 – REVISED AUGUST 2004

electrical characteristics over recommended operating free-air temperature (unless otherwise noted) (continued)

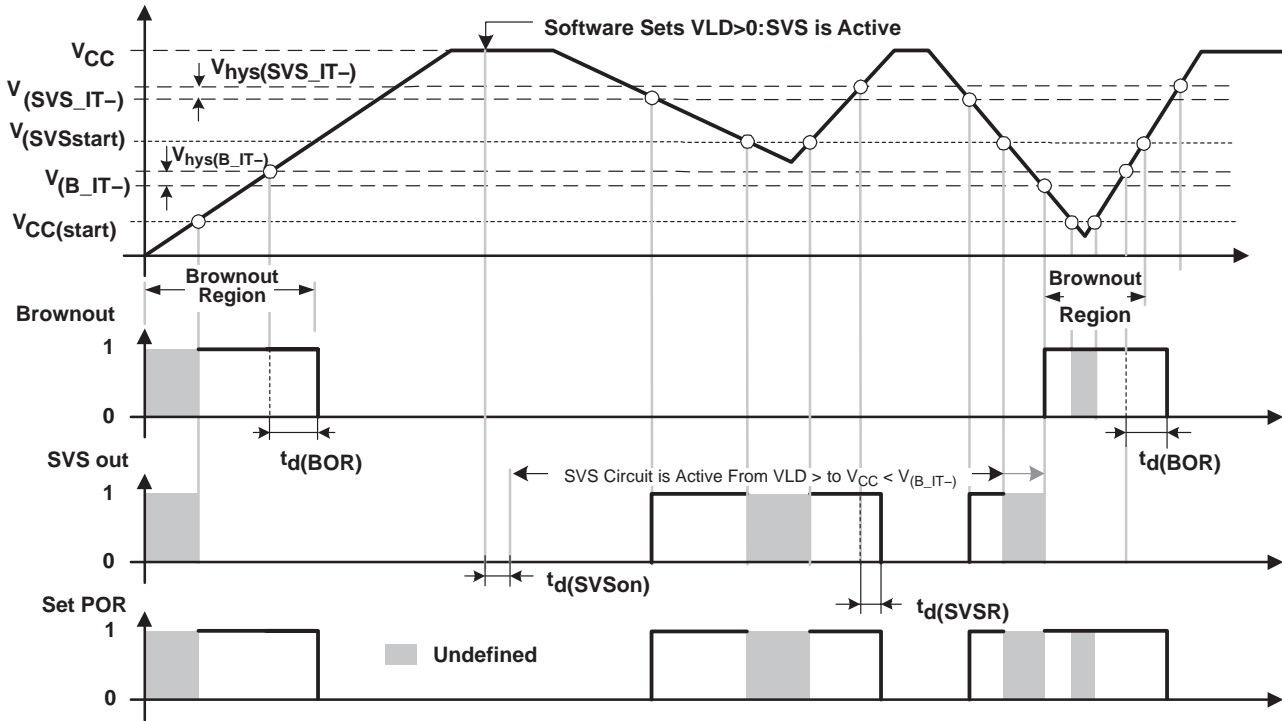

Figure 13. SVS Reset (SVSR) vs Supply Voltage

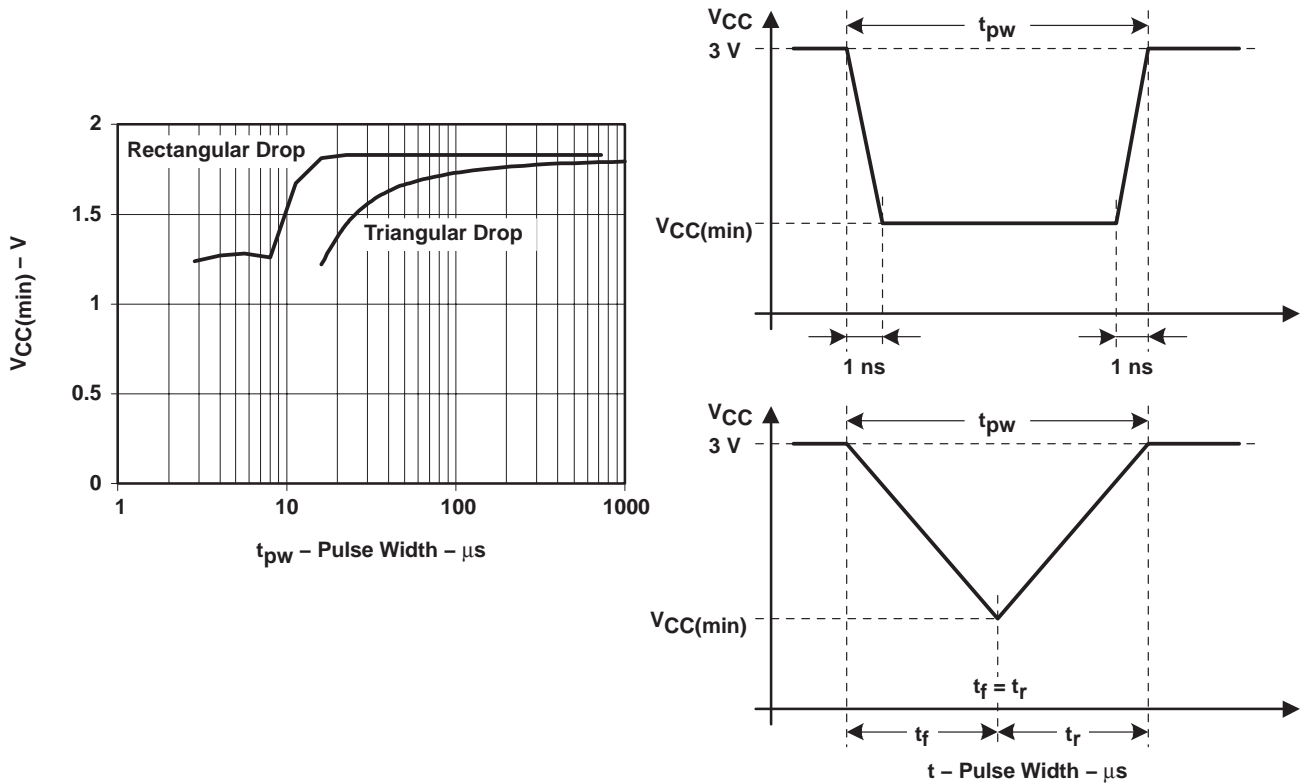

Figure 14.  $V_{CC(min)}$  With a Square Voltage Drop and a Triangle Voltage Drop to Generate an SVS Signal

electrical characteristics over recommended operating free-air temperature (unless otherwise noted) (continued)

DCO

PARAMETER	TEST CONDITIONS	V <sub>CC</sub>	MIN	TYP	MAX	UNIT
f <sub>(DCOCLK)</sub>	N(DCO)=01E0h, FN <sub>8</sub> =FN <sub>4</sub> =FN <sub>3</sub> =FN <sub>2</sub> =0, D = 2, DCOPLUS= 0	2.2 V/3 V		1		MHz
f <sub>(DCO2)</sub>	FN <sub>8</sub> =FN <sub>4</sub> =FN <sub>3</sub> =FN <sub>2</sub> =0, DCOPLUS = 1	2.2 V	0.3	0.65	1.25	MHz
		3 V	0.3	0.7	1.3	
f <sub>(DCO27)</sub>	FN <sub>8</sub> =FN <sub>4</sub> =FN <sub>3</sub> =FN <sub>2</sub> =0, DCOPLUS = 1, (see Note 1)	2.2 V	2.5	5.6	10.5	MHz
		3 V	2.7	6.1	11.3	
f <sub>(DCO2)</sub>	FN <sub>8</sub> =FN <sub>4</sub> =FN <sub>3</sub> =0, FN <sub>2</sub> =1; DCOPLUS = 1	2.2 V	0.7	1.3	2.3	MHz
		3 V	0.8	1.5	2.5	
f <sub>(DCO27)</sub>	FN <sub>8</sub> =FN <sub>4</sub> =FN <sub>3</sub> =0, FN <sub>2</sub> =1; DCOPLUS = 1, (see Note 1)	2.2 V	5.7	10.8	18	MHz
		3 V	6.5	12.1	20	
f <sub>(DCO2)</sub>	FN <sub>8</sub> =FN <sub>4</sub> =0, FN <sub>3</sub> = 1, FN <sub>2</sub> =x; DCOPLUS = 1	2.2 V	1.2	2	3	MHz
		3 V	1.3	2.2	3.5	
f <sub>(DCO27)</sub>	FN <sub>8</sub> =FN <sub>4</sub> =0, FN <sub>3</sub> = 1, FN <sub>2</sub> =x; DCOPLUS = 1, (see Note 1)	2.2 V	9	15.5	25	MHz
		3 V	10.3	17.9	28.5	
f <sub>(DCO2)</sub>	FN <sub>8</sub> =0, FN <sub>4</sub> = 1, FN <sub>3</sub> = FN <sub>2</sub> =x; DCOPLUS = 1	2.2 V	1.8	2.8	4.2	MHz
		3 V	2.1	3.4	5.2	
f <sub>(DCO27)</sub>	FN <sub>8</sub> =0, FN <sub>4</sub> =1, FN <sub>3</sub> = FN <sub>2</sub> =x; DCOPLUS = 1, (see Note 1)	2.2 V	13.5	21.5	33	MHz
		3 V	16	26.6	41	
f <sub>(DCO2)</sub>	FN <sub>8</sub> =1, FN <sub>4</sub> =FN <sub>3</sub> =FN <sub>2</sub> =x; DCOPLUS = 1	2.2 V	2.8	4.2	6.2	MHz
		3 V	4.2	6.3	9.2	
f <sub>(DCO27)</sub>	FN <sub>8</sub> =1, FN <sub>4</sub> =FN <sub>3</sub> =FN <sub>2</sub> =x, DCOPLUS = 1, (see Note 1)	2.2 V	21	32	46	MHz
		3 V	30	46	70	
S <sub>n</sub>	Step size between adjacent DCO taps: S <sub>n</sub> = f <sub>DCO</sub> (Tap n+1) / f <sub>DCO</sub> (Tap n), (see Figure 16 for taps 21 to 27)	1 < TAP ≤ 20	1.06		1.11	
		TAP = 27	1.07		1.17	
D <sub>t</sub>	Temperature drift, N(DCO) = 01E0h, FN <sub>8</sub> =FN <sub>4</sub> =FN <sub>3</sub> =FN <sub>2</sub> =0 D = 2, DCOPLUS = 0, (see Note 2)	2.2 V	-0.2	-0.3	-0.4	%/ <sup>o</sup> C
		3 V	-0.2	-0.3	-0.4	
D <sub>v</sub>	Drift with V <sub>CC</sub> variation, N(DCO) = 01E0h, FN <sub>8</sub> =FN <sub>4</sub> =FN <sub>3</sub> =FN <sub>2</sub> =0 D = 2, DCOPLUS = 0 (see Note 2)	2.2 V/3 V	0	5	15	%/V

- NOTES: 1. Do not exceed the maximum system frequency.  
2. This parameter is not production tested.

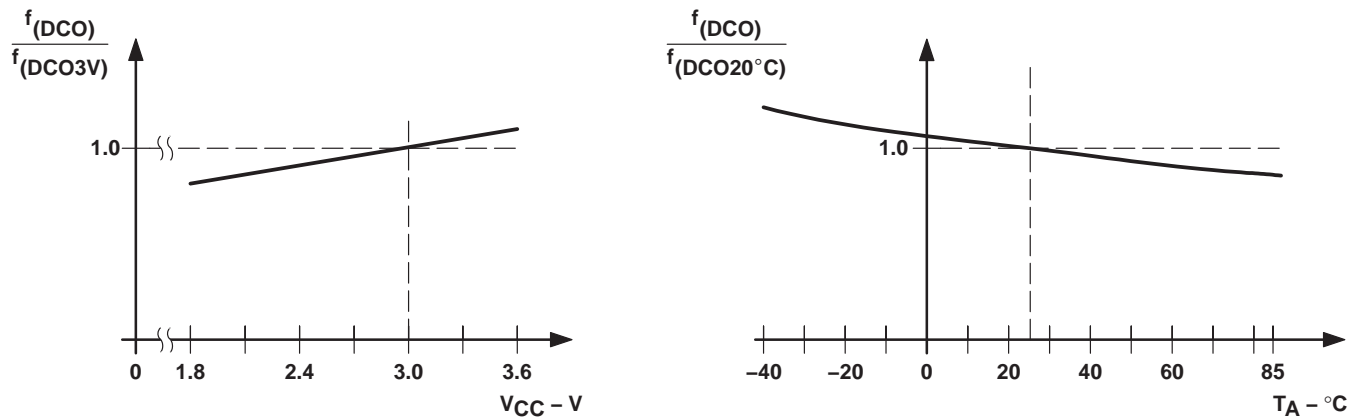

Figure 15. DCO Frequency vs Supply Voltage V<sub>CC</sub> and vs Ambient Temperature

# MSP430xW42x MIXED SIGNAL MICROCONTROLLER

SLAS383A – OCTOBER 2003 – REVISED AUGUST 2004

electrical characteristics over recommended operating free-air temperature (unless otherwise noted) (continued)

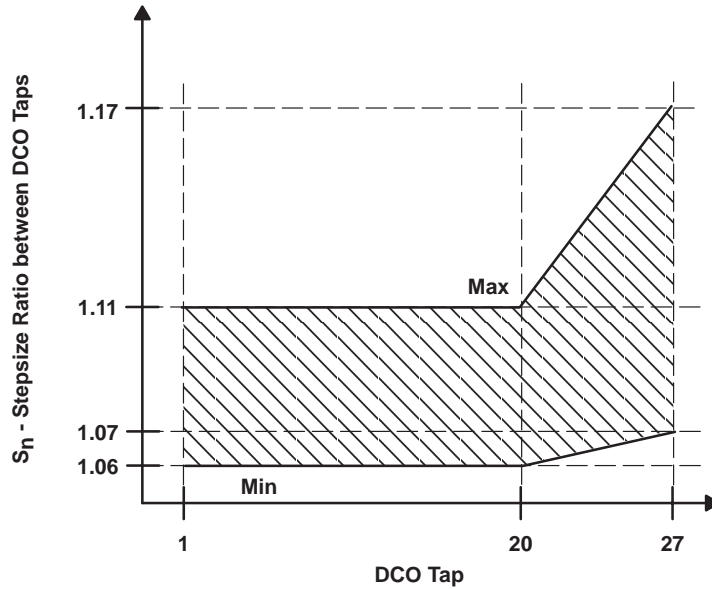

Figure 16. DCO Tap Step Size

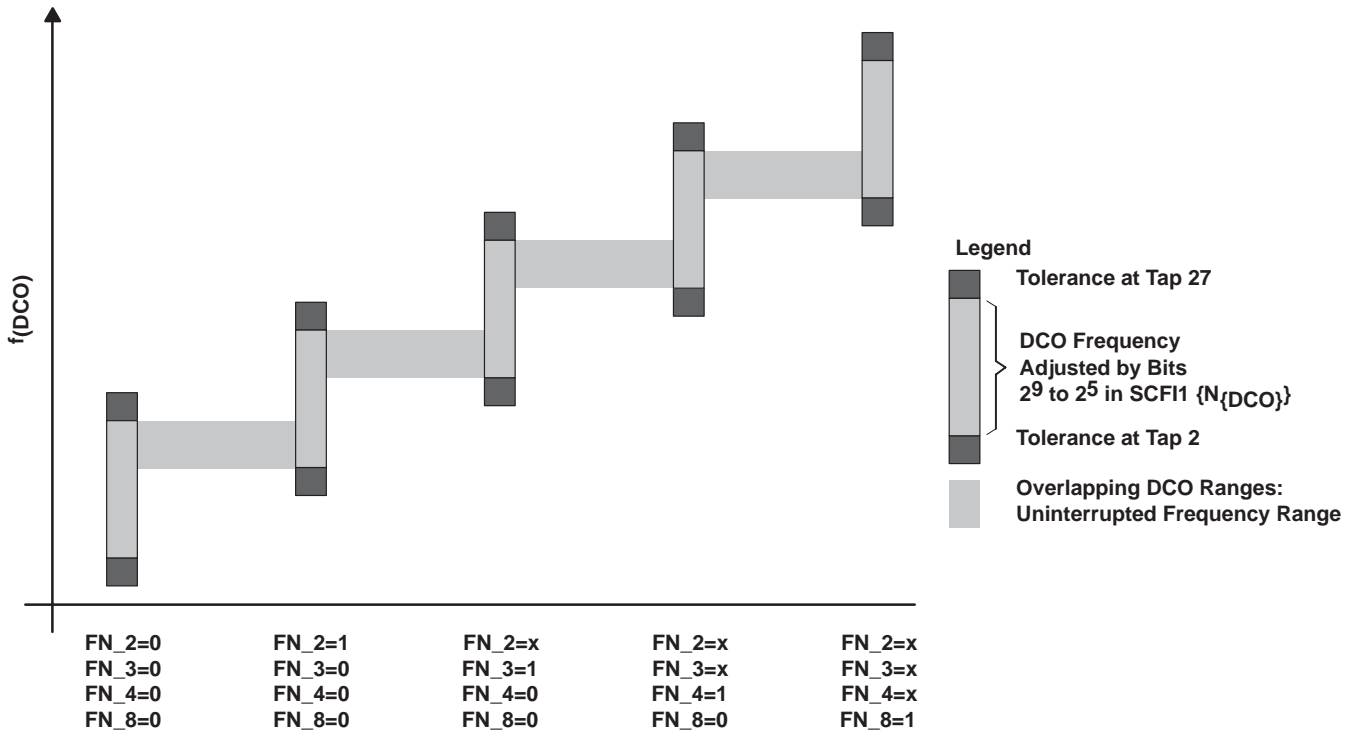

Figure 17. Five Overlapping DCO Ranges Controlled by FN\_x Bits

**crystal oscillator, LFXT1 oscillator (see Notes 1 and 2)**

PARAMETER		TEST CONDITIONS	V <sub>CC</sub>	MIN	TYP	MAX	UNIT
C <sub>XIN</sub>	Integrated load capacitance	OSCCAP <sub>x</sub> = 0h	2.2 V/3 V		0		pF
		OSCCAP <sub>x</sub> = 1h	2.2 V/3 V		10		
		OSCCAP <sub>x</sub> = 2h	2.2 V/3 V		14		
		OSCCAP <sub>x</sub> = 3h	2.2 V/3 V		18		
C <sub>XOUT</sub>	Integrated load capacitance	OSCCAP <sub>x</sub> = 0h	2.2 V/3 V		0		pF
		OSCCAP <sub>x</sub> = 1h	2.2 V/3 V		10		
		OSCCAP <sub>x</sub> = 2h	2.2 V/3 V		14		
		OSCCAP <sub>x</sub> = 3h	2.2 V/3 V		18		
V <sub>IL</sub>	Input levels at XIN	see Note 3	2.2 V/3 V	V <sub>SS</sub>		0.2×V <sub>CC</sub>	V
V <sub>IH</sub>				0.8×V <sub>CC</sub>		V <sub>CC</sub>	

- NOTES:
- The parasitic capacitance from the package and board may be estimated to be 2pF. The effective load capacitor for the crystal is  $(C_{XIN} \times C_{XOUT}) / (C_{XIN} + C_{XOUT})$ . It is independent of XTS\_FLL.
  - To improve EMI on the low-power LFXT1 oscillator, particularly in the LF mode (32 kHz), the following guidelines must be observe:
    - Keep as short a trace as possible between the 'xW42x and the crystal.
    - Design a good ground plane around oscillator pins.
    - Prevent crosstalk from other clock or data lines into oscillator pins XIN and XOUT.
    - Avoid running PCB traces underneath or adjacent to XIN an XOUT pins.
    - Use assembly materials and praxis to avoid any parasitic load on the oscillator XIN and XOUT pins.
    - If conformal coating is used, ensure that it does not induce capacitive/resistive leakage between the oscillator pins.
    - Do not route the XOUT line to the JTAG header to support the serial programming adapter as shown in other documentation. This signal is no longer required for the serial programming adapter.
  - Applies only when using an external logic-level clock source. XTS\_FLL must be set. Not applicable when using a crystal or resonator.
  - External capacitance is recommended for precision real-time clock applications; OSCCAP<sub>x</sub> = 0h.

# MSP430xW42x MIXED SIGNAL MICROCONTROLLER

SLAS383A – OCTOBER 2003 – REVISED AUGUST 2004

## electrical characteristics over recommended operating free-air temperature (unless otherwise noted) (continued)

### Scan IF, port drive, port timing

PARAMETER		TEST CONDITIONS	V <sub>CC</sub>	MIN	TYP	MAX	UNIT
V <sub>OL</sub> (SIFCH <sub>x</sub> )	Voltage drop due to excitation transistor's on-resistance. (see Figure 18)	I(SIFCH <sub>x</sub> ) = 2.0 mA, SIFTEN = 1	3 V			0.3	V
V <sub>OH</sub> (SIFCH <sub>x</sub> ) (see Note 1)	Voltage drop due to damping transistor's on-resistance. (see Figure 18)	I(SIFCH <sub>x</sub> ) = -200 μA, SIFTEN = 1	3 V			0.1	V
V <sub>OL</sub> (SIFCOM)		I(SIFCOM) = 3 mA, SIFSH = 1	2.2 V/3 V	0		0.1	V
I <sub>SIFCHx</sub> (tri-state)		V(SIFCH <sub>x</sub> ) = 0 V to AV <sub>CC</sub> , port function disabled, SIFSH = 1	3 V	-50		50	nA
Δt <sub>d</sub> SIFCH : t <sub>wEx</sub> (tsm) - t <sub>wSIFCH</sub> (see Note 2 and Figure 18)	Change of pulse width of internal signal SIFEX(tsm) to pulse width at pin SIFCH <sub>x</sub>	I(SIFCH <sub>x</sub> ) = 3 mA, t <sub>Ex</sub> (SIFCH <sub>x</sub> ) = 500 ns ±20%	2.2 V/3 V	-20		20	ns

NOTES: 1. SIFCOM=1.5V , supplied externally. (See Figure 19).  
2. Not production tested.

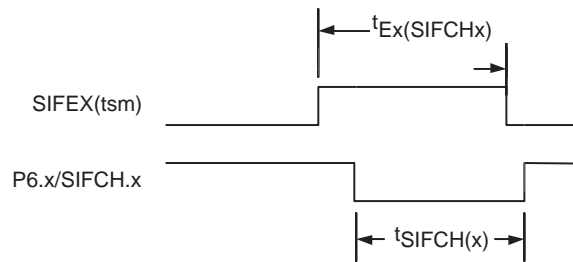

Figure 18. P6.x/SIFCH<sub>x</sub> timing, SIFCH<sub>x</sub> function selected

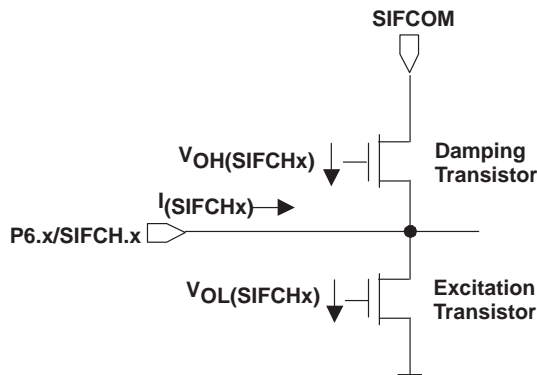

Figure 19. Voltage drop due to on-resistance

**electrical characteristics over recommended operating free-air temperature (unless otherwise noted) (continued)**

**Scan IF, sample capacitor/Ri timing (See Note 1)**

PARAMETER		TEST CONDITIONS	V <sub>CC</sub>	MIN	TYP	MAX	UNIT
C <sub>SHC(SIFCHx)</sub>	Sample capacitance at SIFCHx pin	SIFEx(tsm) = 1, SIFSH = 1	2.2 V/3 V		5	7	pF
R <sub>i(SIFCHx)</sub>	Serial input resistance at the SIFCHx pin	SIFEx(tsm) = 1, SIFSH = 1	2.2 V/3 V		1.5	3	kΩ
t <sub>Hold</sub> (See Notes 1 and 2)	Maximum hold time	ΔV <sub>sample</sub> < 3 mV		62			μs

- NOTES: 1. Values are not production tested.  
 2. The sampled voltage at the sample capacitance varies less than 3 mV (ΔV<sub>sample</sub>) during the hold time t<sub>Hold</sub>. If the voltage is sampled after t<sub>Hold</sub>, the sampled voltage may be any other value.  
 3. The minimum sampling time (7.6 x tau for 1/2 LSB accuracy) with maximum C<sub>SHC(SIFCHx)</sub> and R<sub>i(SIFCHx)</sub> and R<sub>i(source)</sub> is t<sub>sample(min)</sub> ~ 7.6 x C<sub>SHC(SIFCHx)</sub> x (R<sub>i(SIFCHx)</sub> + R<sub>i(source)</sub>) with R<sub>i(source)</sub> estimated at 3 kΩ, t<sub>sample(min)</sub> = 319 ns.

**Scan IF, V<sub>CC</sub>/2 generator**

PARAMETER		TEST CONDITIONS	V <sub>CC</sub>	MIN	TYP	MAX	UNIT
AV <sub>CC</sub>	Analog supply voltage	AV <sub>CC</sub> = DV <sub>CC</sub> (connected together) AV <sub>SS</sub> = DV <sub>SS</sub> (connected together)		2.2		3.6	V
AI <sub>CC</sub>	Scan IF V <sub>CC</sub> /2 generator operating supply current into AV <sub>CC</sub> terminal	C <sub>L</sub> at SIFCOM pin = 470 nF ±20%, f <sub>refresh(SIFCOM)</sub> = 32768 Hz	2.2 V		250	350	nA
			3 V		370	450	
f <sub>refresh(SIFCOM)</sub>	V <sub>CC</sub> /2 refresh frequency	Source clock = ACLK	2.2 V/3 V	30	32.768		kHz
V(SIFCOM)	Output voltage at pin SIFCOM	C <sub>L</sub> at SIFCOM pin = 470 nF ±20%, I <sub>Load</sub> = 1μA		AV <sub>CC</sub> /2 - .05	AV <sub>CC</sub> /2	AV <sub>CC</sub> /2 + .05	V
I <sub>source(SIFCOM)</sub>	SIFCOM source current (see Note 2 and Figure 20)		2.2 V	-500			μA
			3 V	-900			
I <sub>sink(SIFCOM)</sub>	SIFCOM sink current (see Note 2 and Figure 20)		2.2 V	150			nA
			3 V	180			
t <sub>recovery(SIFCOM)</sub>	Time to recover from Voltage Drop on Load	I <sub>Load1</sub> = I <sub>LOAD3</sub> = 0 mA I <sub>Load2</sub> = 3 mA, t <sub>load(on)</sub> = 500ns, C <sub>L</sub> at SIFCOM pin = 470 nF ±20%	2.2 V/3 V			30	μs
t <sub>on(SIFCOM)</sub>	Time to reach 98% after V <sub>CC</sub> /2 is switched on	C <sub>L</sub> at SIFCOM pin = 470 nF ±20% f <sub>refresh(SIFCOM)</sub> = 32768 Hz	2.2 V/3 V		1.7	6	ms
t <sub>VccSettle(SIFCOM)</sub> (See Note 1)	Settling time to ±V <sub>CC</sub> /512 (2 LSB) after AV <sub>CC</sub> voltage change	SIFEN = 1, SIFVCC2 = 1, SIFSH = 0, AV <sub>CC</sub> = AV <sub>CC</sub> - 100 mV f <sub>refresh(SIFCOM)</sub> = 32768 Hz	2.2 V/3 V		80		ms
		AV <sub>CC</sub> = AV <sub>CC</sub> + 100mV f <sub>refresh(SIFCOM)</sub> = 32768 Hz	2.2 V/3 V		3		

- NOTES: 1. The settling time after an AV<sub>CC</sub> voltage change is the time to for the voltage at pin SIFCOM to settle to AV<sub>CC</sub>/2 ± 2LSB.  
 2. The sink and source currents are a function of the voltage at the pin SIFCOM. The maximum currents are reached if SIFCOM is shorted to GND or V<sub>CC</sub>. Due to the topology of the output section (refer to Figure 20) the V<sub>CC</sub>/2 generator can source relatively large currents but can sink only small currents.

# MSP430xW42x MIXED SIGNAL MICROCONTROLLER

SLAS383A – OCTOBER 2003 – REVISED AUGUST 2004

electrical characteristics over recommended operating free-air temperature (unless otherwise noted) (continued)

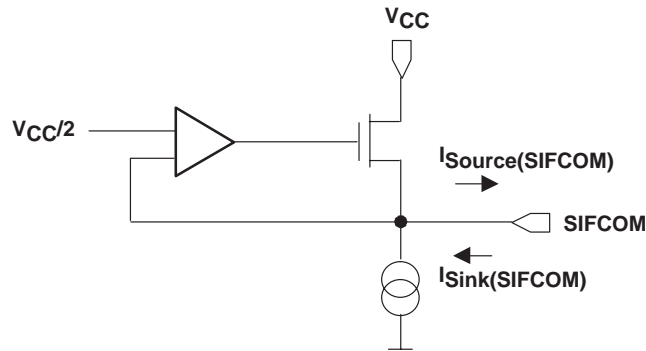

Figure 20. P6.x/SIFCHx timing, SIFCHx function selected

## Scan IF, 10-bit DAC (See Note 1)

PARAMETER		TEST CONDITIONS	V <sub>CC</sub>	MIN	TYP	MAX	UNIT
AV <sub>CC</sub>	Analog supply voltage	AV <sub>CC</sub> = DV <sub>CC</sub> (connected together) AV <sub>SS</sub> = DV <sub>SS</sub> (connected together)		2.2		3.6	V
AI <sub>CC</sub>	Scan IF 10-bit DAC operating supply current into AV <sub>CC</sub> terminal	C <sub>L</sub> at SIFCOM pin = 470 nF ±20%, f <sub>refresh</sub> (SIFCOM) = 32768 Hz	2.2 V		23	45	μA
			3 V		33	60	
Resolution					10		bit
INL	R <sub>L</sub> = 1000 MΩ, C <sub>L</sub> = 20 pF		2.2 V/3 V		±2	±5	LSB
DNL	R <sub>L</sub> = 1000 MΩ, C <sub>L</sub> = 20 pF		2.2 V/3 V			±1	LSB
EZS	Zero Scale Error		2.2 V/3 V			±10	mV
E <sub>G</sub>	Gain Error		2.2 V/3 V			0.6	%
R <sub>O</sub>	Output resistance				25	50	kΩ
t <sub>on</sub> (SIFDAC)	On time after AV <sub>CC</sub> of SIFDAC is switched on	V <sub>+SIFCA</sub> - V <sub>SIFDAC</sub> = ±6 mV	2.2 V/3 V			2.0	μs
t <sub>Settle</sub> (SIFDAC)	Settling time	SIFDAC code = 1C0h → 240h V <sub>SIFDAC</sub> (240h) - V <sub>+SIFCA</sub> = +6 mV	2.2 V/3 V			2.0	μs
		SIFDAC code = 240h → 1C0h, V <sub>SIFDAC</sub> (1C0h) - V <sub>+SIFCA</sub> = -6 mV	2.2 V/3 V			2.0	μs

NOTES: 1. The SIFDAC operates from AV<sub>CC</sub> and SIFV<sub>SS</sub>. All parameters are based on these references.

**electrical characteristics over recommended operating free-air temperature (unless otherwise noted) (continued)**

**Scan IF, Comparator**

PARAMETER		TEST CONDITIONS	V <sub>CC</sub>	MIN	TYP	MAX	UNIT
AV <sub>CC</sub>	Analog supply voltage	AV <sub>CC</sub> = DV <sub>CC</sub> (connected together) AV <sub>SS</sub> = DV <sub>SS</sub> (connected together)		2.2		3.6	V
AI <sub>CC</sub>	Scan IF comparator operating supply current into AV <sub>CC</sub> terminal		2.2 V		25	35	μA
			3 V		35	50	
V <sub>IC</sub>	Common Mode Input Voltage Range	(see Note 1)	2.2 V/3 V	0.9		AV <sub>CC</sub> - 0.5	V
V <sub>Offset</sub>	Input Offset Voltage		2.2 V/3 V			±30	mV
dV <sub>Offset</sub> /dT	Temperature coefficient of V <sub>Offset</sub>		2.2 V/3 V		10		μV/°C
dV <sub>Offset</sub> /dV <sub>CC</sub>	V <sub>Offset</sub> supply voltage (V <sub>CC</sub> ) sensitivity		2.2 V/3 V		0.3		mV/V
V <sub>hys</sub>	Input Voltage Hysteresis	V <sub>+terminal</sub> = V <sub>-terminal</sub> = 0.5 × V <sub>CC</sub>	2.2V	0		5.0	mV
			3.0V	0		6.0	
t <sub>on</sub> (SIFCA)	On time after SIFCA is switched on	V <sub>+SIFCA</sub> - V <sub>SIFDAC</sub> = +6 mV V <sub>+SIFCA</sub> = 0.5 × AV <sub>CC</sub>	2.2 V/3 V			2.0	us
t <sub>Settle</sub> (SIFCA)	Settle time	V <sub>+SIFCA</sub> - V <sub>SIFDAC</sub> = -12 mV → 6 mV V <sub>+SIFCA</sub> = 0.5 × AV <sub>CC</sub>	2.2 V/3 V			2.0	us

NOTES: 1. The comparator output is reliable when at least one of the input signals is within the common mode input voltage range.

**Scan IF, SIFCLK Oscillator**

PARAMETER		TEST CONDITIONS	V <sub>CC</sub>	MIN	TYP	MAX	UNIT
AV <sub>CC</sub>	Analog supply voltage	AV <sub>CC</sub> = DV <sub>CC</sub> (connected together) AV <sub>SS</sub> = DV <sub>SS</sub> (connected together)		2.2		3.6	V
AI <sub>CC</sub>	Scan IF oscillator operating supply current into AV <sub>CC</sub> terminal		2.2 V			75	μA
			3 V			90	
f <sub>SIFCLKG</sub> = 0	Scan IF oscillator at minimum setting	T <sub>A</sub> =25°C, SIFCLKFQ=0000	SIFNOM = 0	1.8		3.2	MHz
			SIFNOM = 1	0.45		0.8	
f <sub>SIFCLKG</sub> = 8	Scan IF oscillator at nominal setting	T <sub>A</sub> =25°C, SIFCLKFQ=0000	SIFNOM = 0		4		
			SIFNOM = 1		1		
f <sub>SIFCLKG</sub> = 15	Scan IF oscillator at maximum setting	T <sub>A</sub> =25°C, SIFCLKFQ=0000	SIFNOM = 0	4.48		6.8	
			SIFNOM = 1	1.12		1.7	
t <sub>on</sub> (SIFCLKG)	Settling time to full operation after V <sub>CC</sub> is switched on		2.2 V/3 V	150		500	ns
S <sub>(SIFCLK)</sub>	Frequency Change per ±1 SIFCLKFQ(SIFCTL5) step	S <sub>(SIFCLK)</sub> = f <sub>(SIFCLKFQ + 1)</sub> / f <sub>(SIFCLKFQ)</sub>	2.2 V/3 V	1.01	1.05	1.18	Hz/Hz
D <sub>t</sub>	Temperature Coefficient	SIFCLKFQ(SIFCTL5) = 8	2.2 V/3 V			0.35	%/°C
D <sub>V</sub>	Frequency vs. supply voltage V <sub>CC</sub> variation	SIFCLKFQ(SIFCTL5) = 8	2.2 V/3 V			2	%/V

# MSP430xW42x MIXED SIGNAL MICROCONTROLLER

SLAS383A – OCTOBER 2003 – REVISED AUGUST 2004

## electrical characteristics over recommended operating free-air temperature (unless otherwise noted) (continued)

### Flash Memory

PARAMETER		TEST CONDITIONS	V <sub>CC</sub>	MIN	NOM	MAX	UNIT
V <sub>CC</sub> (PGM/ERASE)	Program and Erase supply voltage			2.7		3.6	V
f <sub>FTG</sub>	Flash Timing Generator frequency			257		476	kHz
I <sub>PGM</sub>	Supply current from DV <sub>CC</sub> during program		2.7 V/ 3.6 V		3	5	mA
I <sub>ERASE</sub>	Supply current from DV <sub>CC</sub> during erase		2.7 V/ 3.6 V		3	7	mA
t <sub>CPT</sub>	Cumulative program time	see Note 1	2.7 V/ 3.6 V			4	ms
t <sub>CMErase</sub>	Cumulative mass erase time	see Note 2	2.7 V/ 3.6 V	200			ms
	Program/Erase endurance			10 <sup>4</sup>	10 <sup>5</sup>		cycles
t <sub>Retention</sub>	Data retention duration	T <sub>J</sub> = 25°C		100			years
t <sub>Word</sub>	Word or byte program time	see Note 3			35		t <sub>FTG</sub>
t <sub>Block, 0</sub>	Block program time for 1 <sup>st</sup> byte or word				30		
t <sub>Block, 1-63</sub>	Block program time for each additional byte or word				21		
t <sub>Block, End</sub>	Block program end-sequence wait time				6		
t <sub>Mass Erase</sub>	Mass erase time				5297		
t <sub>Seg Erase</sub>	Segment erase time				4819		

- NOTES: 1. The cumulative program time must not be exceeded when writing to a 64-byte flash block. This parameter applies to all programming methods: individual word/byte write and block write modes.
2. The mass erase duration generated by the flash timing generator is at least 11.1ms ( = 5297x1/f<sub>FTG,max</sub> = 5297x1/476kHz). To achieve the required cumulative mass erase time the Flash Controller's mass erase operation can be repeated until this time is met. (A worst case minimum of 19 cycles are required).
3. These values are hardwired into the Flash Controller's state machine (t<sub>FTG</sub> = 1/f<sub>FTG</sub>).

### JTAG Interface

PARAMETER		TEST CONDITIONS	V <sub>CC</sub>	MIN	NOM	MAX	UNIT
f <sub>TCK</sub>	TCK input frequency	see Note 1	2.2 V	0		5	MHz
			3 V	0		10	MHz
R <sub>Internal</sub>	Internal pull-up resistance on TMS, TCK, TDI/TCLK	see Note 2	2.2 V/ 3 V	25	60	90	kΩ

- NOTES: 1. f<sub>TCK</sub> may be restricted to meet the timing requirements of the module selected.
2. TMS, TDI/TCLK, and TCK pull-up resistors are implemented in all versions.

### JTAG Fuse (see Note 1)

PARAMETER		TEST CONDITIONS	V <sub>CC</sub>	MIN	NOM	MAX	UNIT
V <sub>CC</sub> (FB)	Supply voltage during fuse-blow condition	T <sub>A</sub> = 25°C		2.5			V
V <sub>FB</sub>	Voltage level on TDI/TCLK for fuse-blow			6		7	V
I <sub>FB</sub>	Supply current into TDI/TCLK during fuse blow					100	mA
t <sub>FB</sub>	Time to blow fuse					1	ms

- NOTES: 1. Once the fuse is blown, no further access to the MSP430 JTAG/Test and emulation features is possible. The JTAG block is switched to bypass mode.



APPLICATION INFORMATION

input/output schematic

Port P1, P1.0 to P1.5, input/output with Schmitt-trigger

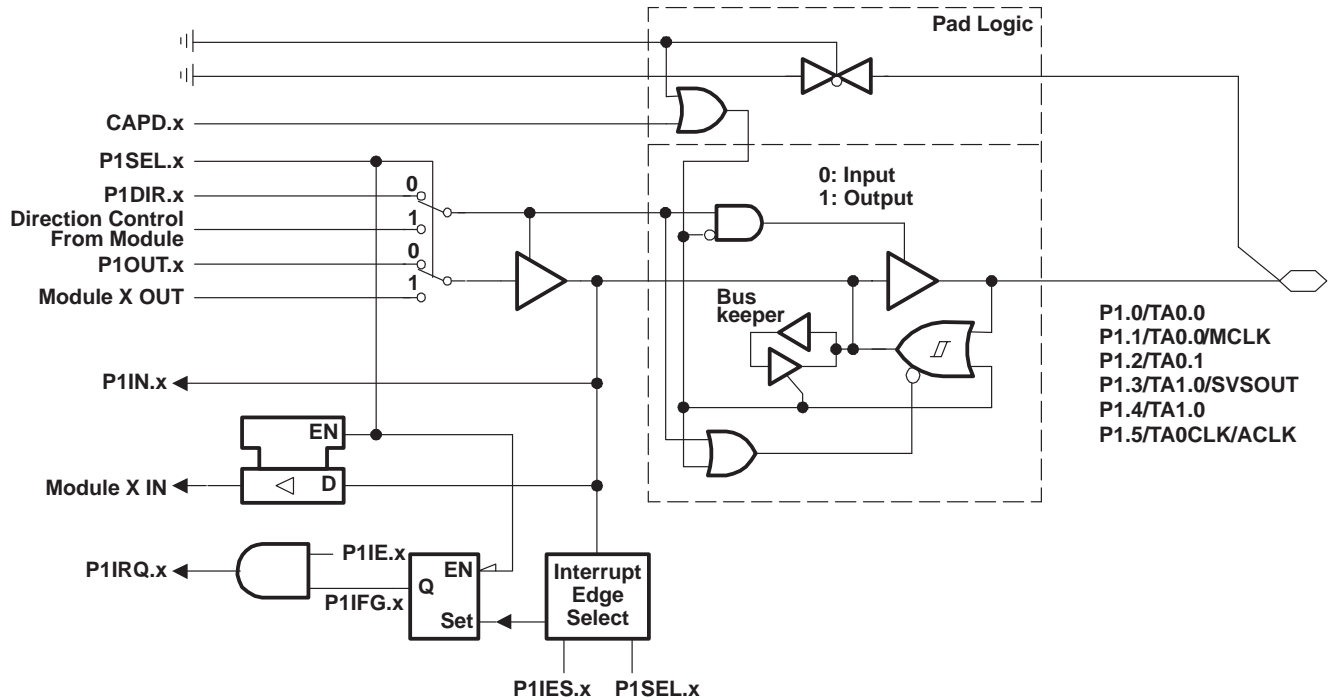

NOTE:  $0 \leq x \leq 5$ .  
Port Function is Active if CAPD.x = 0

PnSEL.x	PnDIR.x	Direction Control From Module	PnOUT.x	Module X OUT	PnIN.x	Module X IN	PnIE.x	PnIFG.x	PnIES.x
P1SEL.0	P1DIR.0	P1DIR.0	P1OUT.0	Out0 Sig.†	P1IN.0	CCI0A†	P1IE.0	P1IFG.0	P1IES.0
P1SEL.1	P1DIR.1	P1DIR.1	P1OUT.1	MCLK	P1IN.1	CCI0B†	P1IE.1	P1IFG.1	P1IES.1
P1SEL.2	P1DIR.2	P1DIR.2	P1OUT.2	Out1 Sig.†	P1IN.2	CCI1A†	P1IE.2	P1IFG.2	P1IES.2
P1SEL.3	P1DIR.3	P1DIR.3	P1OUT.3	SVSOUT	P1IN.3	CCI0B‡	P1IE.3	P1IFG.3	P1IES.3
P1SEL.4	P1DIR.4	P1DIR.4	P1OUT.4	Out0 Sig.‡	P1IN.4	CCI0A‡	P1IE.4	P1IFG.4	P1IES.4
P1SEL.5	P1DIR.5	P1DIR.5	P1OUT.5	ACLK	P1IN.5	T0ACLK†	P1IE.5	P1IFG.5	P1IES.5

† Timer0\_A  
‡ Timer1\_A

# MSP430xW42x MIXED SIGNAL MICROCONTROLLER

SLAS383A – OCTOBER 2003 – REVISED AUGUST 2004

## APPLICATION INFORMATION

### input/output schematic (continued)

#### Port P1, P1.6, P1.7 input/output with Schmitt-trigger

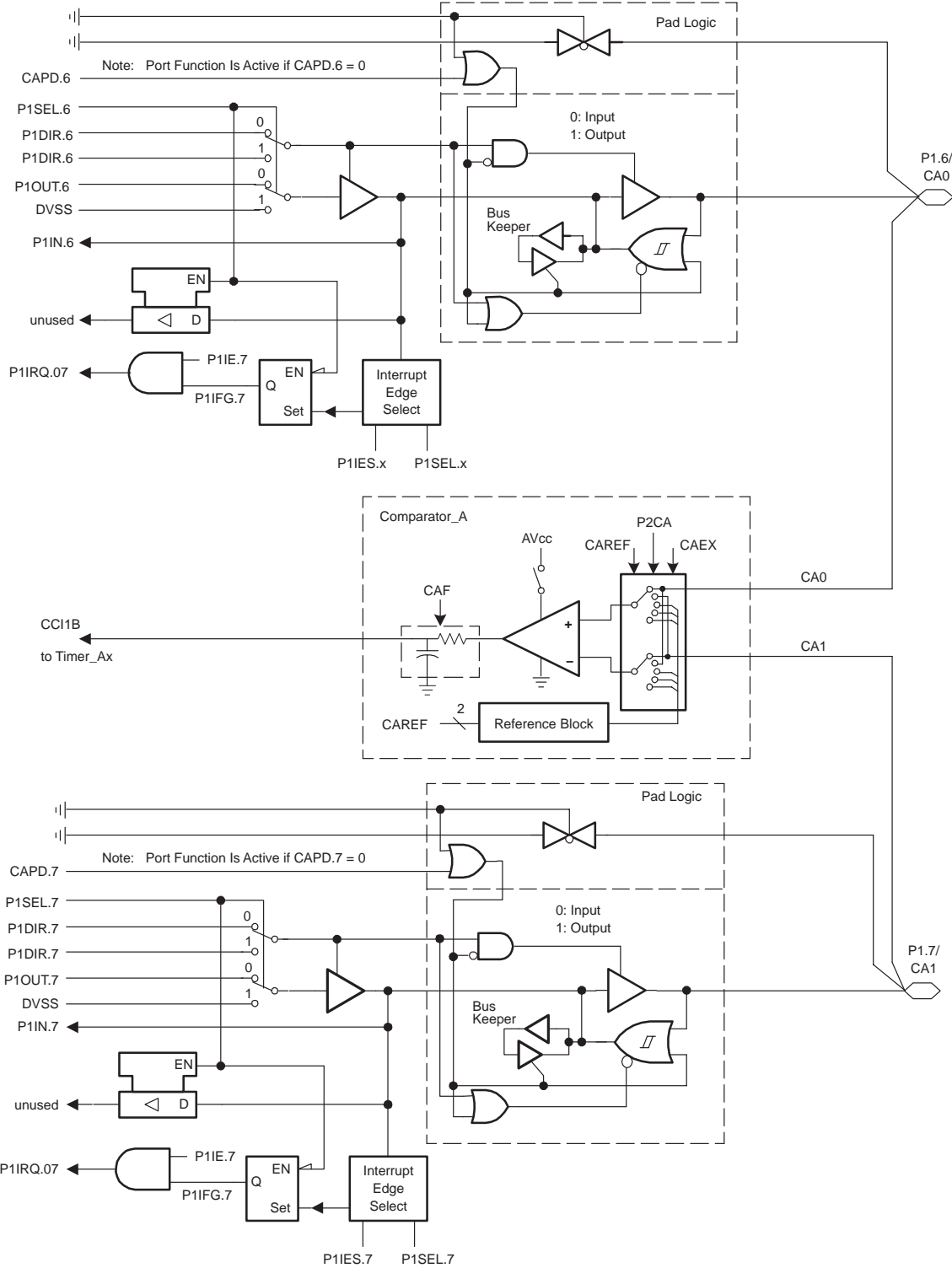

APPLICATION INFORMATION

input/output schematic (continued)

port P2, P2.0 to P2.7, input/output with Schmitt-trigger

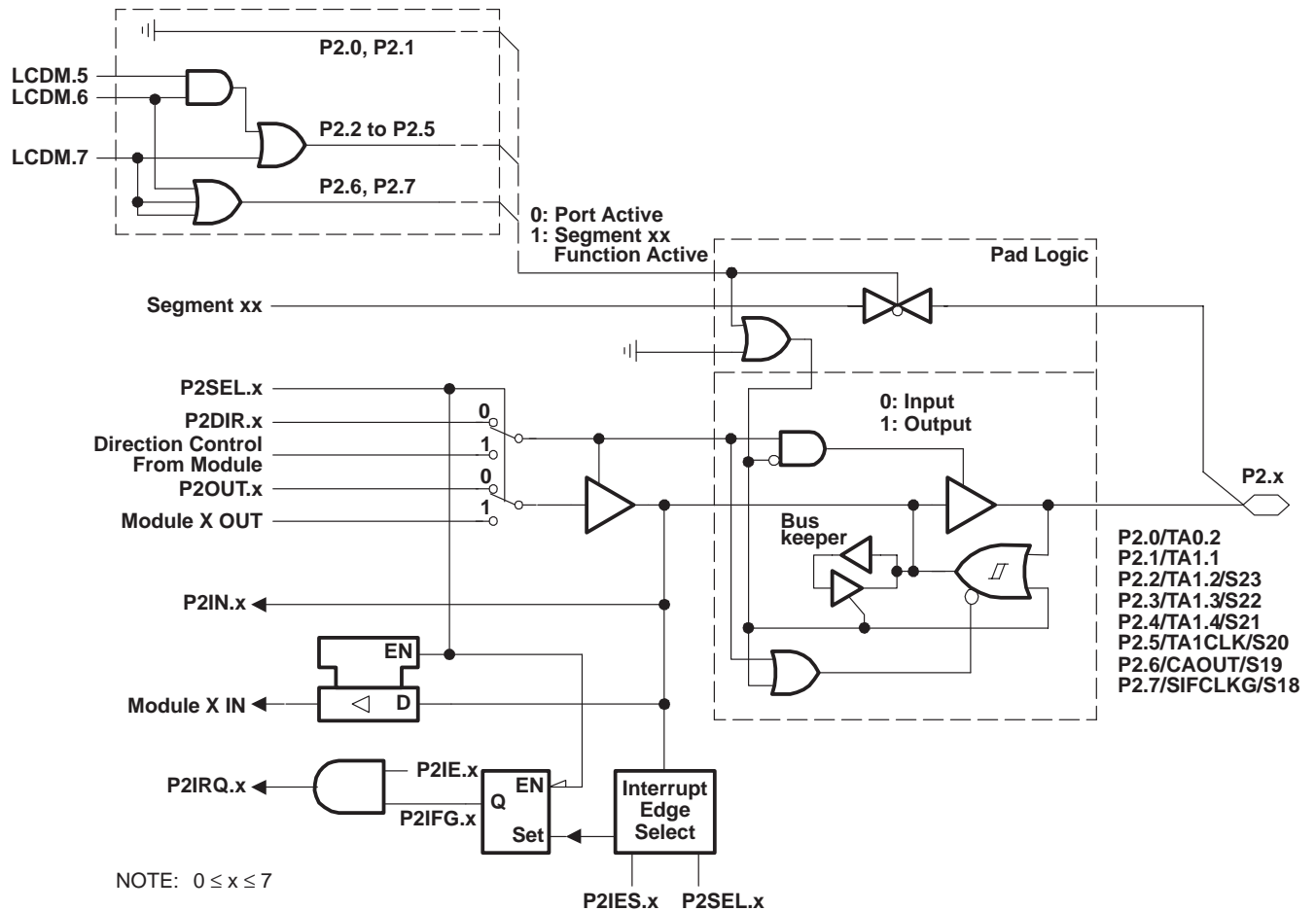

PnSEL.x	PnDIR.x	Direction Control From Module	PnOUT.x	Module X OUT	PnIN.x	Module X IN	PnIE.x	PnIFG.x	PnIES.x
P2SEL.0	P2DIR.0	P2DIR.0	P2OUT.0	Out2 Sig.†	P2IN.0	CCI2A†	P2IE.0	P2IFG.0	P2IES.0
P2SEL.1	P2DIR.1	P2DIR.1	P2OUT.1	Out1 Sig.‡	P2IN.1	CCI1A‡	P2IE.1	P2IFG.1	P2IES.1
P2SEL.2	P2DIR.2	P2DIR.2	P2OUT.2	Out2 Sig.‡	P2IN.2	CCI2A‡	P2IE.2	P2IFG.2	P2IES.2
P2SEL.3	P2DIR.3	P2DIR.3	P2OUT.3	Out3 Sig.‡	P2IN.3	CCI3A‡	P2IE.3	P2IFG.3	P2IES.3
P2SEL.4	P2DIR.4	P2DIR.4	P2OUT.4	Out4 Sig.‡	P2IN.4	CCI4A‡	P2IE.4	P2IFG.4	P2IES.4
P2SEL.5	P2DIR.5	P2DIR.5	P2OUT.5	DVSS	P2IN.5	TA1CLK1‡	P2IE.5	P2IFG.5	P2IES.5
P2SEL.6	P2DIR.6	P2DIR.6	P2OUT.6	CAOUT	P2IN.6	Unused	P2IE.6	P2IFG.6	P2IES.6
P2SEL.7	P2DIR.7	P2DIR.7	P2OUT.7	SIFCLKG§	P2IN.7	Unused	P2IE.7	P2IFG.7	P2IES.7

†Timer0\_A  
‡Timer1\_A  
§Scan IF

# MSP430xW42x MIXED SIGNAL MICROCONTROLLER

SLAS383A – OCTOBER 2003 – REVISED AUGUST 2004

## APPLICATION INFORMATION

input/output schematic (continued)

port P3, P3.0, P3.7, input/output with Schmitt-trigger

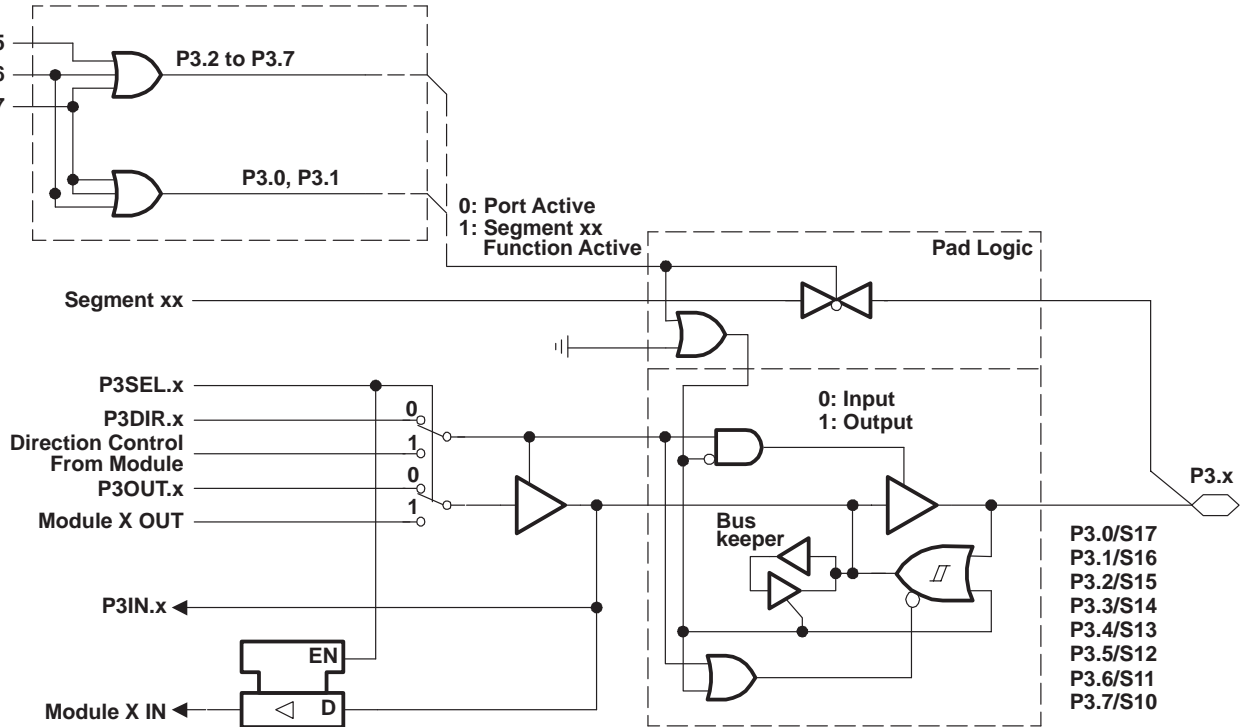

NOTE:  $0 \leq x \leq 7$

PnSEL.x	PnDIR.x	Direction Control From Module	PnOUT.x	Module X OUT	PnIN.x	Module X IN
P3SEL.0	P3DIR.0	P3DIR.0	P3OUT.0	DVSS	P3IN.0	Unused
P3SEL.1	P3DIR.1	P3DIR.1	P3OUT.1	DVSS	P3IN.1	Unused
P3SEL.2	P3DIR.2	P3DIR.2	P3OUT.2	DVSS	P3IN.2	Unused
P3SEL.3	P3DIR.3	P3DIR.3	P3OUT.3	DVSS	P3IN.3	Unused
P3SEL.4	P3DIR.4	P3DIR.4	P3OUT.4	DVSS	P3IN.4	Unused
P3SEL.5	P3DIR.5	P3DIR.5	P3OUT.5	DVSS	P3IN.5	Unused
P3SEL.6	P3DIR.6	P3DIR.6	P3OUT.6	DVSS	P3IN.6	Unused
P3SEL.7	P3DIR.7	P3DIR.7	P3OUT.7	DVSS	P3IN.7	Unused

APPLICATION INFORMATION

input/output schematic (continued)

port P4, P4.0 to P4.7, input/output with Schmitt-trigger

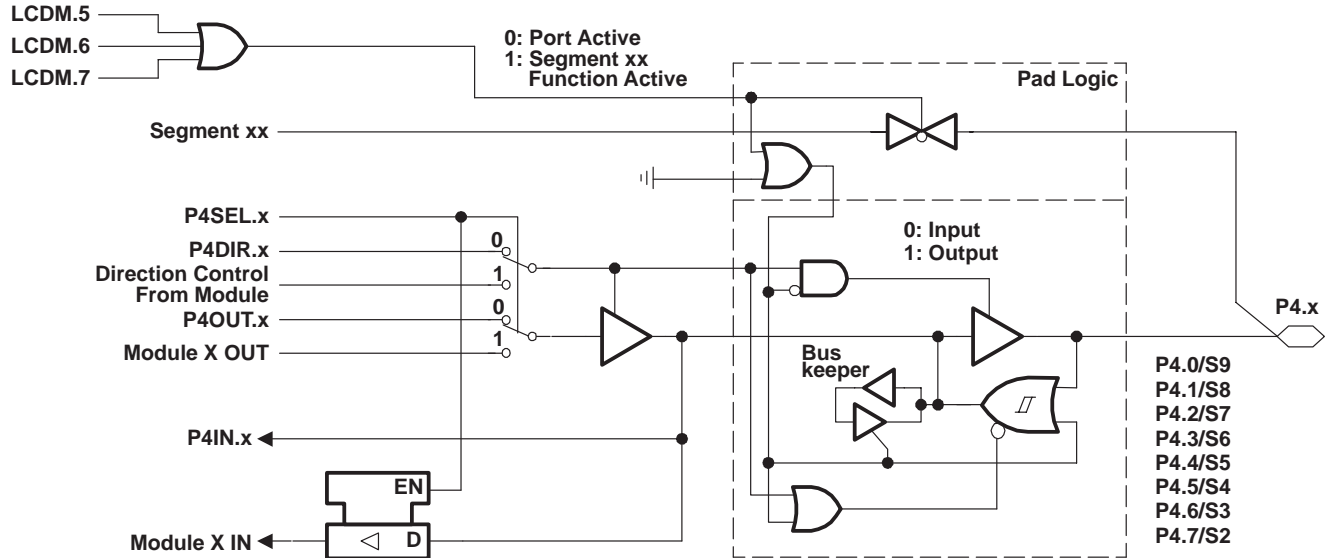

NOTE:  $0 \leq x \leq 7$

PnSEL.x	PnDIR.x	Direction Control From Module	PnOUT.x	Module X OUT	PnIN.x	Module X IN
P4SEL.0	P4DIR.0	P4DIR.0	P4OUT.0	DVSS	P4IN.0	Unused
P4SEL.1	P4DIR.1	P4DIR.1	P4OUT.1	DVSS	P4IN.1	Unused
P4SEL.2	P4DIR.2	P4DIR.2	P4OUT.2	DVSS	P4IN.2	Unused
P4SEL.3	P4DIR.3	P4DIR.3	P4OUT.3	DVSS	P4IN.3	Unused
P4SEL.4	P4DIR.4	P4DIR.4	P4OUT.4	DVSS	P4IN.4	Unused
P4SEL.5	P4DIR.5	P4DIR.5	P4OUT.5	DVSS	P4IN.5	Unused
P4SEL.6	P4DIR.6	P4DIR.6	P4OUT.6	DVSS	P4IN.6	Unused
P4SEL.7	P4DIR.7	P4DIR.7	P4OUT.7	DVSS	P4IN.7	Unused

# MSP430xW42x MIXED SIGNAL MICROCONTROLLER

SLAS383A – OCTOBER 2003 – REVISED AUGUST 2004

## APPLICATION INFORMATION

input/output schematic (continued)

port P5, P5.0, P5.1, input/output with Schmitt-trigger

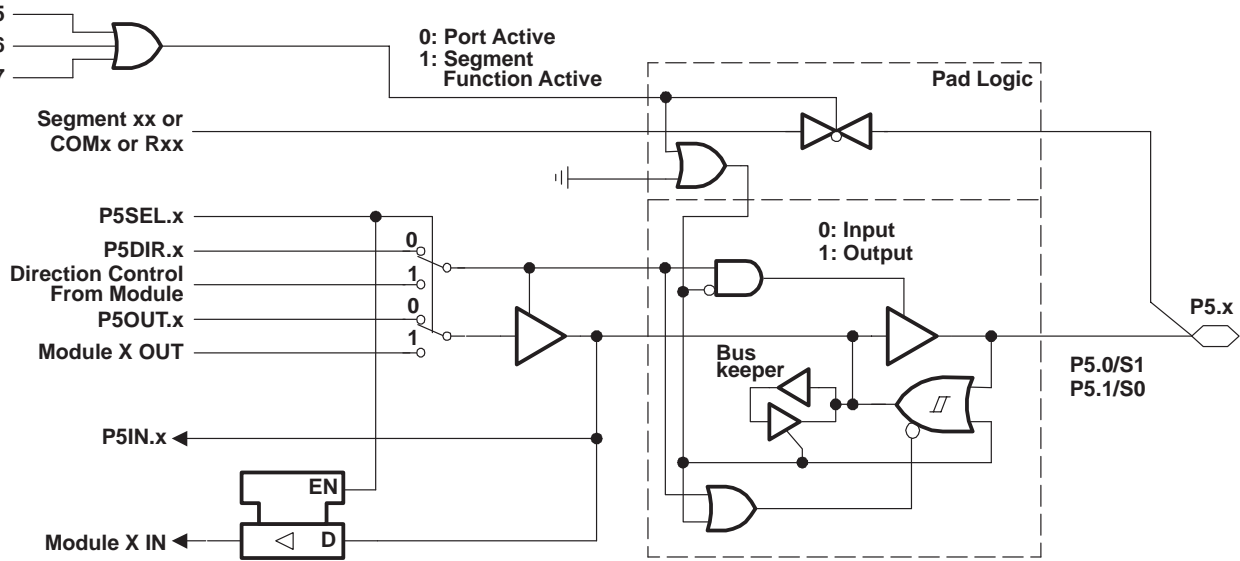

NOTE: x = 0, 1

PnSEL.x	PnDIR.x	Direction Control From Module	PnOUT.x	Module X OUT	PnIN.x	Module X IN	Segment
P5SEL.0	P5DIR.0	P5DIR.0	P5OUT.0	DVSS	P5IN.0	Unused	S1
P5SEL.1	P5DIR.1	P5DIR.1	P5OUT.1	DVSS	P5IN.1	Unused	S0

APPLICATION INFORMATION

input/output schematic (continued)

port P5, P5.2, P5.4, input/output with Schmitt-trigger

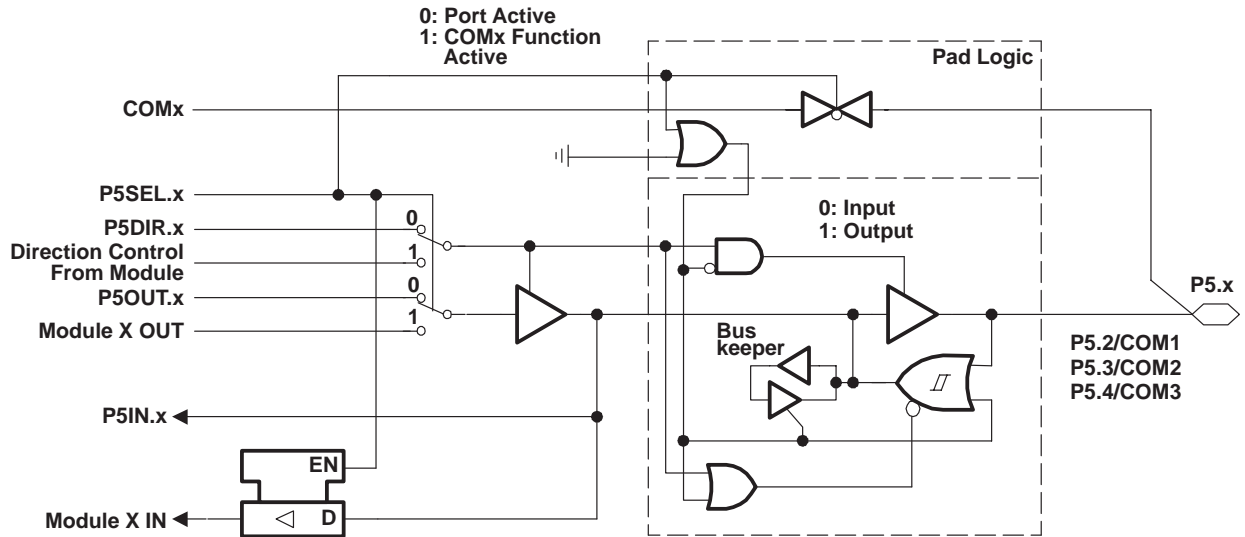

NOTE:  $2 \leq x \leq 4$

PnSEL.x	PnDIR.x	Direction Control From Module	PnOUT.x	Module X OUT	PnIN.x	Module X IN	COMx
P5SEL.2	P5DIR.2	P5DIR.2	P5OUT.2	DVSS	P5IN.2	Unused	COM1
P5SEL.3	P5DIR.3	P5DIR.3	P5OUT.3	DVSS	P5IN.3	Unused	COM2
P5SEL.4	P5DIR.4	P5DIR.4	P5OUT.4	DVSS	P5IN.4	Unused	COM3

NOTE:

The direction control bits P5SEL.2, P5SEL.3, and P5SEL.4 are used to distinguish between port and common functions. Note that a 4MUX LCD requires all common signals COM3 to COM0, a 3MUX LCD requires COM2 to COM0, 2MUX LCD requires COM1 to COM0, and a static LCD requires only COM0.

# MSP430xW42x MIXED SIGNAL MICROCONTROLLER

SLAS383A – OCTOBER 2003 – REVISED AUGUST 2004

## APPLICATION INFORMATION

input/output schematic (continued)

port P5, P5.5 to P5.7, input/output with Schmitt-trigger

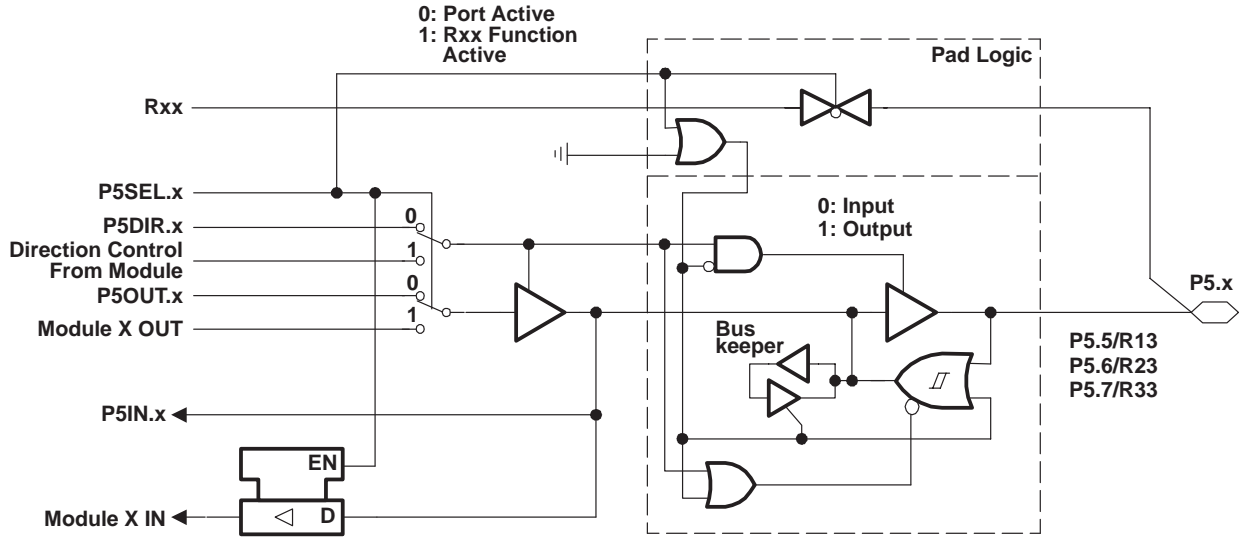

NOTE:  $5 \leq x \leq 7$

PnSEL.x	PnDIR.x	Direction Control From Module	PnOUT.x	Module X OUT	PnIN.x	Module X IN	Rxx
P5SEL.5	P5DIR.5	P5DIR.5	P5OUT.5	DVSS	P5IN.5	Unused	R13
P5SEL.6	P5DIR.6	P5DIR.6	P5OUT.6	DVSS	P5IN.6	Unused	R23
P5SEL.7	P5DIR.7	P5DIR.7	P5OUT.7	DVSS	P5IN.7	Unused	R33

### NOTE:

The direction control bits P5SEL.5, P5SEL.6, and P5SEL.7 are used to distinguish between port and LCD analog level functions. Note that 4MUX and 3MUX LCDs require all Rxx signals R33 to R03, a 2MUX LCD requires R33, R13, and R03, and a static LCD requires only R33 and R03.

APPLICATION INFORMATION

input/output schematic (continued)

port P6, P6.0, P6.1, P6.2, P6.4, P6.5, input/output with Schmitt-trigger

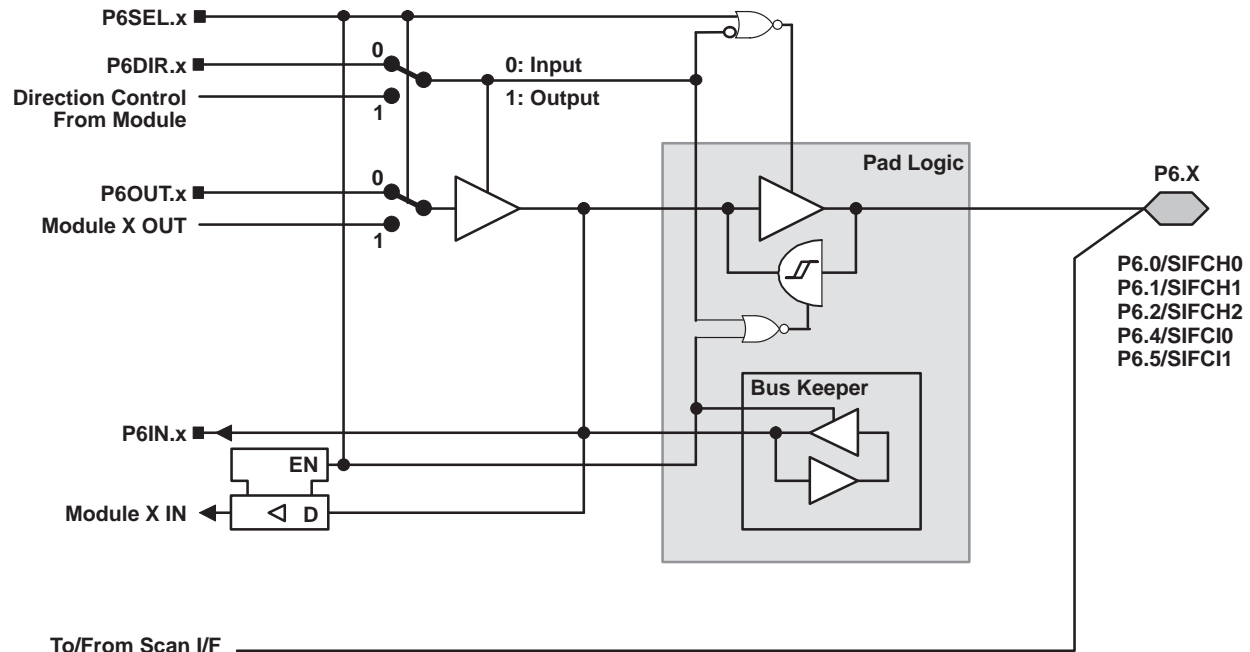

To/From Scan I/F  
P6SEL.x must be set if the corresponding pins are used by the Scan IF.

x: Bit Identifier = 0, 1, 2, 4, or 5

NOTE: Analog signals applied to digital gates can cause current flow from the positive to the negative terminal. The throughput current flows if the analog signal is in the range of transitions 0→1 or 1→0. The value of the throughput current depends on the driving capability of the gate. For MSP430, it is approximately 100 μA.  
Use P6SEL.x=1 to prevent throughput current. P6SEL.x should be set, if an analog signal is applied to the pin.

PnSEL.x	PnDIR.x	Dir. Control From Module	PnOUT.x	Module X OUT	PnIN.x	Module X IN
P6Sel.0	P6DIR.0	P6DIR.0	P6OUT.0	DV <sub>SS</sub>	P6IN.0	unused
P6Sel.1	P6DIR.1	P6DIR.1	P6OUT.1	DV <sub>SS</sub>	P6IN.1	unused
P6Sel.2	P6DIR.2	P6DIR.2	P6OUT.2	DV <sub>SS</sub>	P6IN.2	unused
P6Sel.4	P6DIR.4	P6DIR.4	P6OUT.4	DV <sub>SS</sub>	P6IN.4	unused
P6Sel.5	P6DIR.5	P6DIR.5	P6OUT.5	DV <sub>SS</sub>	P6IN.5	unused

NOTE: The signal at pins P6.x/SIFCHx and P6.x/SIFCIx are shared by Port P6 and the San IF module. P6SEL.x must be set if the corresponding pins are used by the Scan IF.

# MSP430xW42x MIXED SIGNAL MICROCONTROLLER

SLAS383A – OCTOBER 2003 – REVISED AUGUST 2004

## APPLICATION INFORMATION

### input/output schematic (continued)

#### port P6, P6.3 input/output with Schmitt-trigger

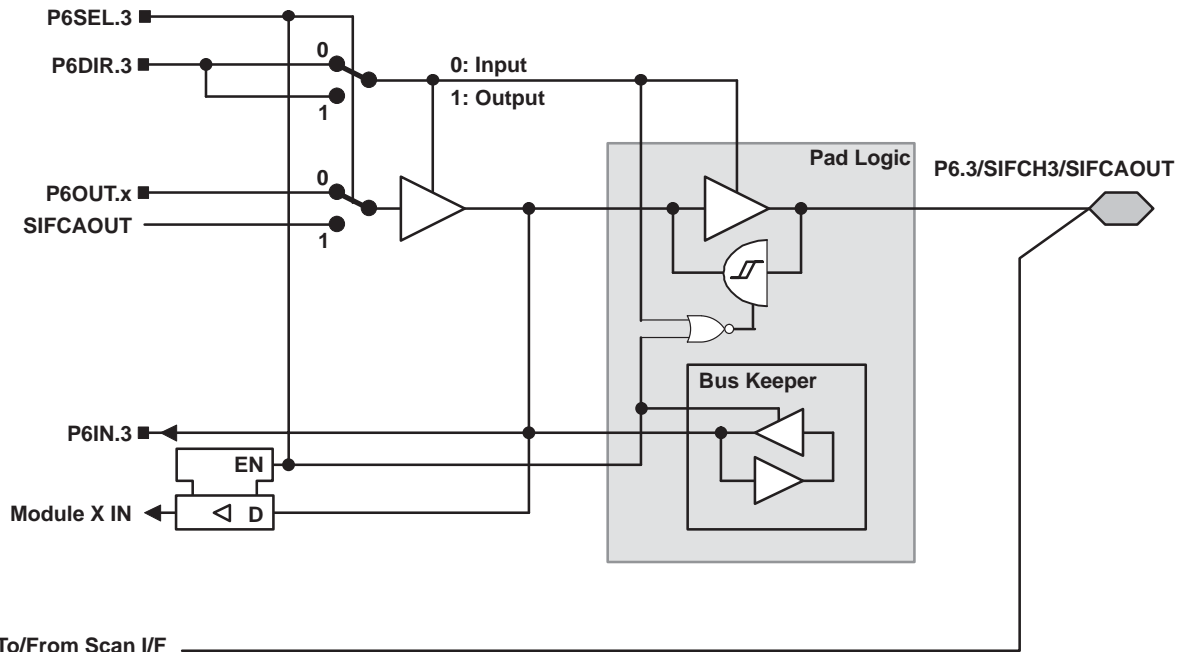

To/From Scan I/F

P6SEL.x must be set if the corresponding pins are used by the Scan I/F.

NOTE: Analog signals applied to digital gates can cause current flow from the positive to the negative terminal. The throughput current flows if the analog signal is in the range of transitions 0→1 or 1→0. The value of the throughput current depends on the driving capability of the gate. For MSP430, it is approximately 100  $\mu$ A.

Use P6SEL.x=1 to prevent throughput current. P6SEL.x should be set, if an analog signal is applied to the pin.

P6SEL.3	P6DIR.3	Port Function
0	0	P6.3 Input
0	1	P6.3 Output
1	0	SIFCH3 (Scan IF channel 3 excitation output and comparator input)
1	1	SIFCAOUT (Comparator output)

APPLICATION INFORMATION

input/output schematic (continued)

port P6, P6.6 input/output with Schmitt-trigger

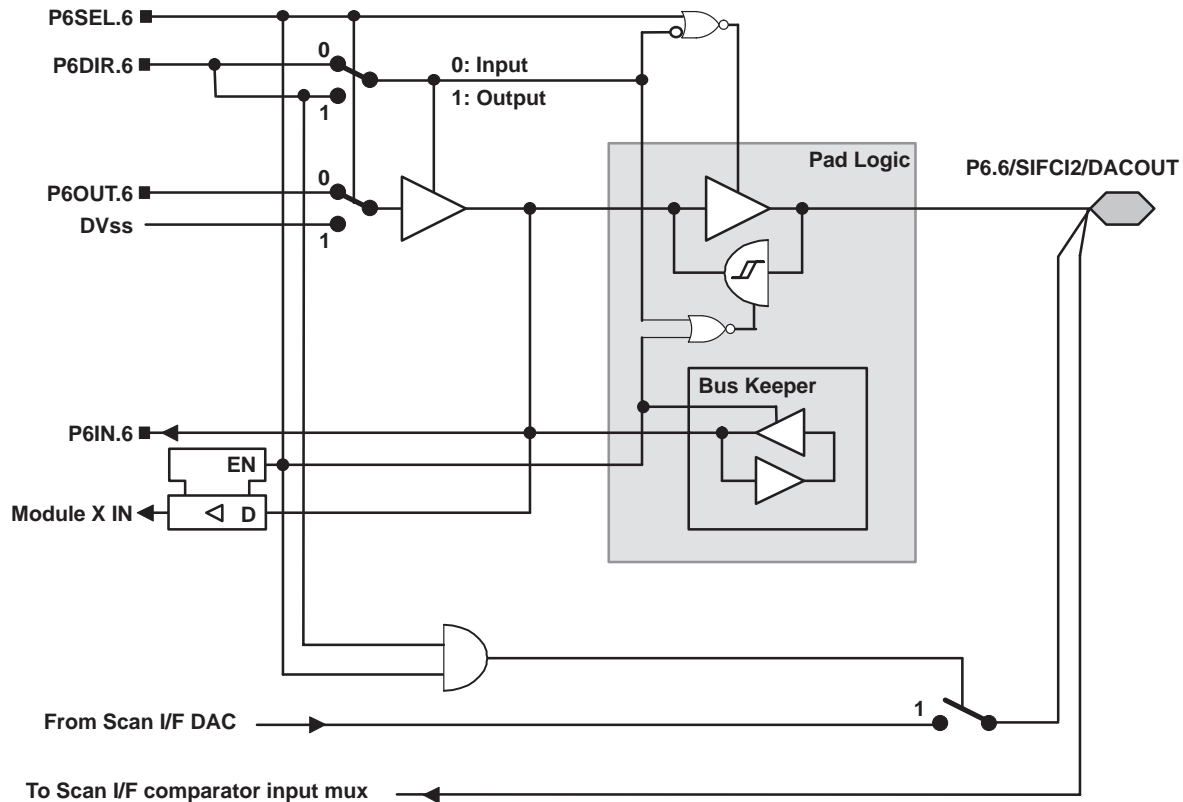

P6SEL.x must be set if the corresponding pins are used by the Scan IF.

NOTE: Analog signals applied to digital gates can cause current flow from the positive to the negative terminal. The throughput current flows if the analog signal is in the range of transitions 0→1 or 1→0. The value of the throughput current depends on the driving capability of the gate. For MSP430, it is approximately 100  $\mu$ A.

Use P6SEL.x=1 to prevent throughput current. P6SEL.x should be set, if an analog signal is applied to the pin.

P6SEL.6	P6DIR.6	Port Function
0	0	P6.6 Input
0	1	P6.6 Output
1	0	SIFCI2 (Scan IF channel 2 comparator input)
1	1	SIFDAOUT (Scan IF DAC output)



APPLICATION INFORMATION

JTAG pins TMS, TCK, TDI/TCLK, TDO/TDI, input/output with Schmitt-trigger or output

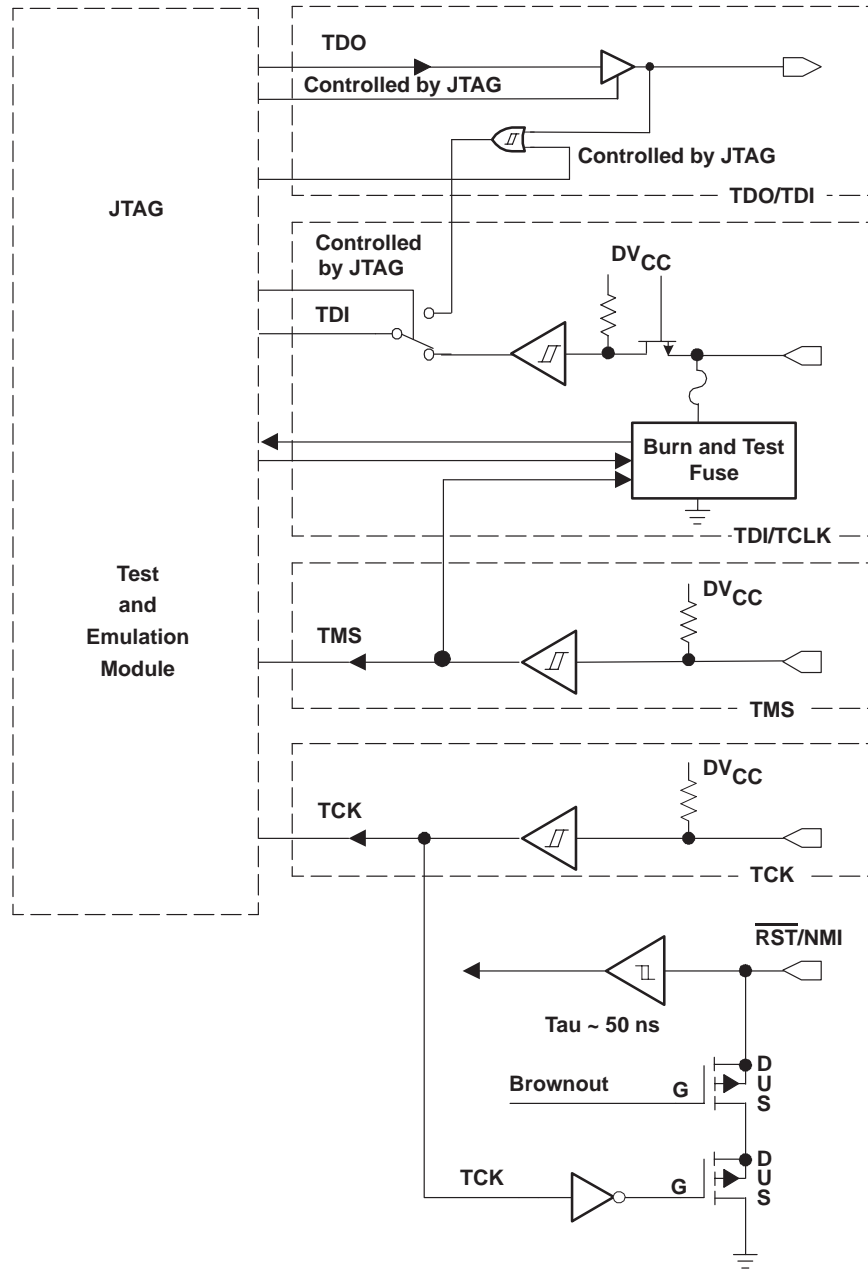

**APPLICATION INFORMATION**

**JTAG fuse check mode**

MSP430 devices that have the fuse on the TDI/TCLK terminal have a fuse check mode that tests the continuity of the fuse the first time the JTAG port is accessed after a power-on reset (POR). When activated, a fuse check current,  $I_{TF}$ , of 1.8 mA at 3 V can flow from the TDI/TCLK pin to ground if the fuse is not burned. Care must be taken to avoid accidentally activating the fuse check mode and increasing overall system power consumption. Activation of the fuse check mode occurs with the first negative edge on the TMS pin after power up or if the TMS is being held low during power up. The second positive edge on the TMS pin deactivates the fuse check mode. After deactivation, the fuse check mode remains inactive until another POR occurs. After each POR the fuse check mode has the potential to be activated.

The fuse check current only flows when the fuse check mode is active and the TMS pin is in a low state (see Figure 21). Therefore, the additional current flow can be prevented by holding the TMS pin high (default condition).

The JTAG pins are terminated internally, and therefore do not require external termination.

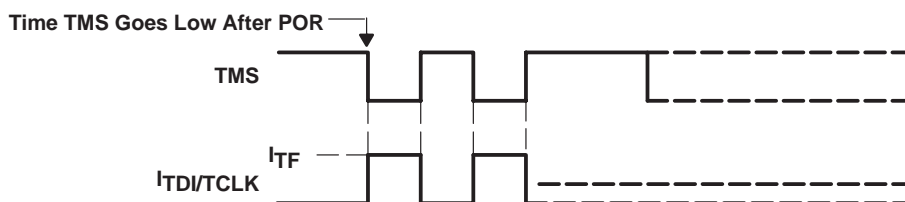

**Figure 21. Fuse Check Mode Current, MSP430FW42x**

PM (S-PQFP-G64)

PLASTIC QUAD FLATPACK

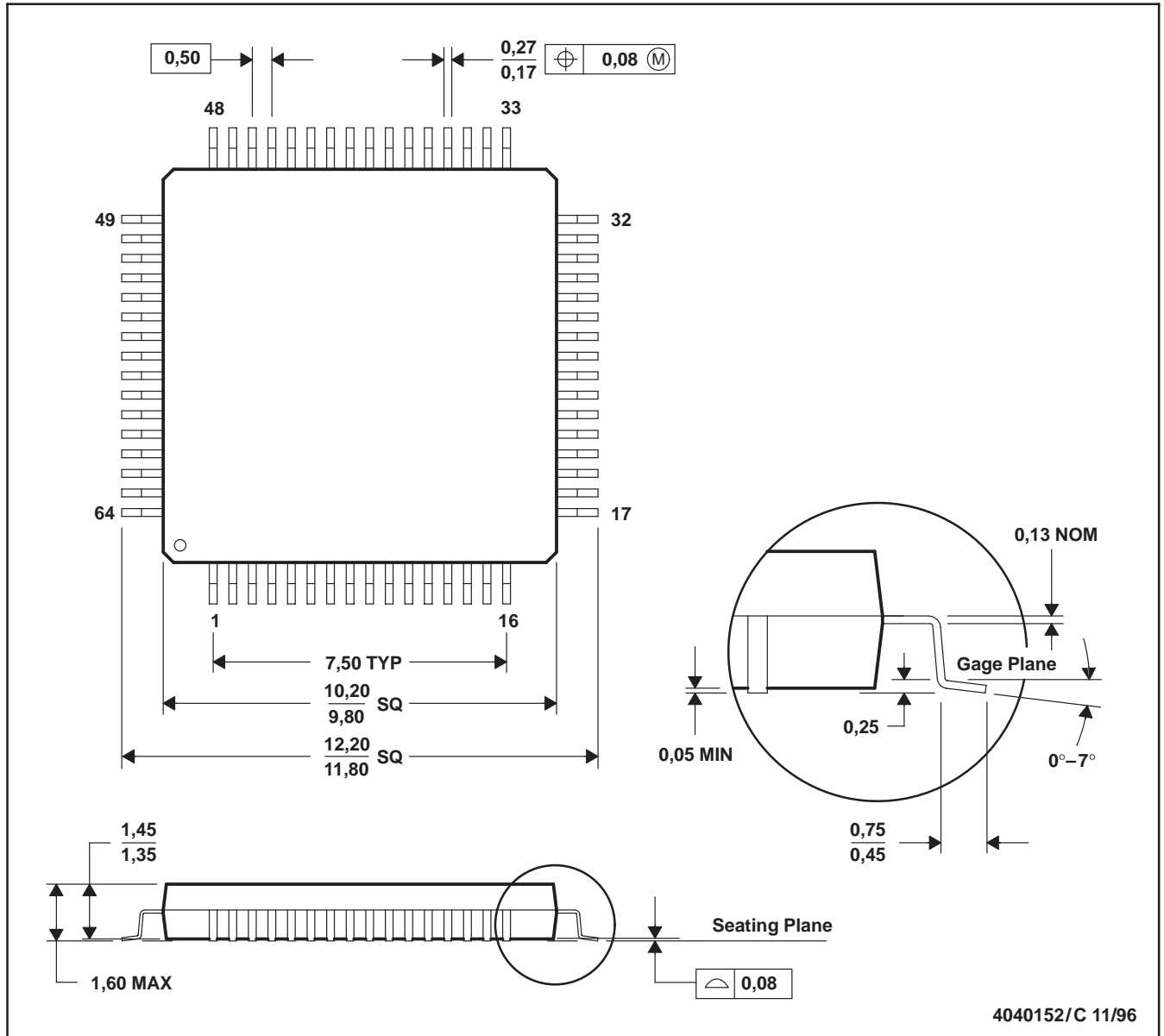

- NOTES: A. All linear dimensions are in millimeters.  
 B. This drawing is subject to change without notice.  
 C. Falls within JEDEC MS-026  
 D. May also be thermally enhanced plastic with leads connected to the die pads.

## IMPORTANT NOTICE

Texas Instruments Incorporated and its subsidiaries (TI) reserve the right to make corrections, modifications, enhancements, improvements, and other changes to its products and services at any time and to discontinue any product or service without notice. Customers should obtain the latest relevant information before placing orders and should verify that such information is current and complete. All products are sold subject to TI's terms and conditions of sale supplied at the time of order acknowledgment.

TI warrants performance of its hardware products to the specifications applicable at the time of sale in accordance with TI's standard warranty. Testing and other quality control techniques are used to the extent TI deems necessary to support this warranty. Except where mandated by government requirements, testing of all parameters of each product is not necessarily performed.

TI assumes no liability for applications assistance or customer product design. Customers are responsible for their products and applications using TI components. To minimize the risks associated with customer products and applications, customers should provide adequate design and operating safeguards.

TI does not warrant or represent that any license, either express or implied, is granted under any TI patent right, copyright, mask work right, or other TI intellectual property right relating to any combination, machine, or process in which TI products or services are used. Information published by TI regarding third-party products or services does not constitute a license from TI to use such products or services or a warranty or endorsement thereof. Use of such information may require a license from a third party under the patents or other intellectual property of the third party, or a license from TI under the patents or other intellectual property of TI.

Reproduction of information in TI data books or data sheets is permissible only if reproduction is without alteration and is accompanied by all associated warranties, conditions, limitations, and notices. Reproduction of this information with alteration is an unfair and deceptive business practice. TI is not responsible or liable for such altered documentation.

Resale of TI products or services with statements different from or beyond the parameters stated by TI for that product or service voids all express and any implied warranties for the associated TI product or service and is an unfair and deceptive business practice. TI is not responsible or liable for any such statements.

Following are URLs where you can obtain information on other Texas Instruments products and application solutions:

<b>Products</b>		<b>Applications</b>	
Amplifiers	<a href="http://amplifier.ti.com">amplifier.ti.com</a>	Audio	<a href="http://www.ti.com/audio">www.ti.com/audio</a>
Data Converters	<a href="http://dataconverter.ti.com">dataconverter.ti.com</a>	Automotive	<a href="http://www.ti.com/automotive">www.ti.com/automotive</a>
DSP	<a href="http://dsp.ti.com">dsp.ti.com</a>	Broadband	<a href="http://www.ti.com/broadband">www.ti.com/broadband</a>
Interface	<a href="http://interface.ti.com">interface.ti.com</a>	Digital Control	<a href="http://www.ti.com/digitalcontrol">www.ti.com/digitalcontrol</a>
Logic	<a href="http://logic.ti.com">logic.ti.com</a>	Military	<a href="http://www.ti.com/military">www.ti.com/military</a>
Power Mgmt	<a href="http://power.ti.com">power.ti.com</a>	Optical Networking	<a href="http://www.ti.com/opticalnetwork">www.ti.com/opticalnetwork</a>
Microcontrollers	<a href="http://microcontroller.ti.com">microcontroller.ti.com</a>	Security	<a href="http://www.ti.com/security">www.ti.com/security</a>
		Telephony	<a href="http://www.ti.com/telephony">www.ti.com/telephony</a>
		Video & Imaging	<a href="http://www.ti.com/video">www.ti.com/video</a>
		Wireless	<a href="http://www.ti.com/wireless">www.ti.com/wireless</a>

Mailing Address: Texas Instruments  
Post Office Box 655303 Dallas, Texas 75265