

## ADC342x Quad-Channel, 12-Bit, 25-MSPS to 125-MSPS, Analog-to-Digital Converter

### 1 Features

- Quad Channel
- 12-Bit Resolution
- Single Supply: 1.8 V
- Serial LVDS Interface (SLVDS)
- Flexible Input Clock Buffer with Divide-by-1, -2, -4
- SNR = 70.2 dBFS, SFDR = 87 dBc at  $f_{IN} = 70$  MHz
- Ultra-Low Power Consumption:
  - 98 mW/Ch at 125 MSPS
- Channel Isolation: 105 dB
- Internal Dither and Chopper
- Support for Multi-Chip Synchronization
- Pin-to-Pin Compatible with 14-Bit Version
- Package: VQFN-56 (8 mm × 8 mm)

### 2 Applications

- Multi-Carrier, Multi-Mode Cellular Base Stations
- Radar and Smart Antenna Arrays
- Munitions Guidance
- Motor Control Feedback
- Network and Vector Analyzers
- Communications Test Equipment
- Nondestructive Testing
- Microwave Receivers
- Software-Defined Radios (SDRs)
- Quadrature and Diversity Radio Receivers

### 3 Description

The ADC342x are a high-linearity, ultra-low power, quad-channel, 12-bit, 25-MSPS to 125-MSPS, analog-to-digital converter (ADC) family. The devices are designed specifically to support demanding, high input frequency signals with large dynamic range requirements. An input clock divider allows more flexibility for system clock architecture design while the SYSREF input enables complete system synchronization. The ADC342x family supports serial low-voltage differential signaling (LVDS) and JESD204B interfaces in order to reduce the number of interface lines, thus allowing for high system integration density. The serial LVDS interface is two-wire, where each ADC data are serialized and output over two LVDS pairs. An internal phase-locked loop (PLL) multiplies the incoming ADC sampling clock to derive the bit clock that is used to serialize the 12-bit output data from each channel. In addition to the serial data streams, the frame and bit clocks are also transmitted as LVDS outputs.

#### Device Information<sup>(1)</sup>

PART NUMBER	PACKAGE	BODY SIZE (NOM)
ADC342x	VQFN (48)	8.00 mm × 8.00 mm

(1) For all available packages, see the orderable addendum at the end of the datasheet.

#### Performance at $f_S = 125$ MSPS, $f_{IN} = 10$ MHz (SNR = 70.4 dBFS, SFDR = 93 dBc)

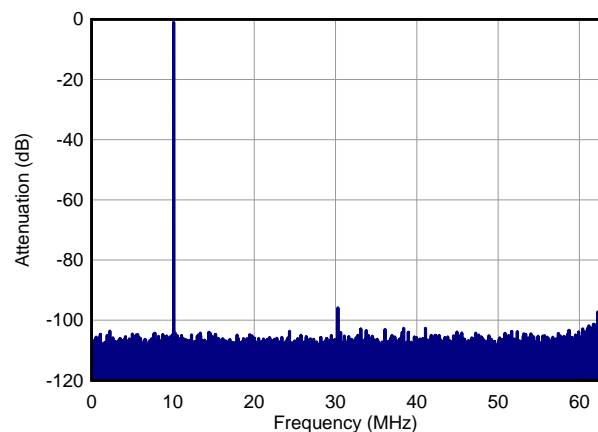

D001



## Table of Contents

<b>1 Features</b> .....	<b>1</b>	<b>8 Parameter Measurement Information</b> .....	<b>21</b>
<b>2 Applications</b> .....	<b>1</b>	8.1 Timing Diagrams .....	21
<b>3 Description</b> .....	<b>1</b>	<b>9 Detailed Description</b> .....	<b>23</b>
<b>4 Revision History</b> .....	<b>2</b>	9.1 Overview .....	23
<b>5 Device Comparison Table</b> .....	<b>3</b>	9.2 Functional Block Diagram .....	23
<b>6 Pin Configuration and Functions</b> .....	<b>3</b>	9.3 Feature Description .....	24
<b>7 Specifications</b> .....	<b>5</b>	9.4 Device Functional Modes .....	27
7.1 Absolute Maximum Ratings .....	5	9.5 Programming .....	29
7.2 Handling Ratings .....	5	9.6 Register Maps .....	33
7.3 Recommended Operating Conditions .....	5	<b>10 Applications and Implementation</b> .....	<b>44</b>
7.4 Thermal Information .....	6	10.1 Application Information .....	44
7.5 Performance Modes .....	6	10.2 Typical Applications .....	44
7.6 Electrical Characteristics: ADC3421, ADC3422 .....	7	<b>11 Power Supply Recommendations</b> .....	<b>47</b>
7.7 Electrical Characteristics: ADC3423, ADC3424 .....	7	<b>12 Layout</b> .....	<b>48</b>
7.8 Electrical Characteristics: General .....	8	12.1 Layout Guidelines .....	48
7.9 AC Performance: ADC3421 .....	9	12.2 Layout Example .....	48
7.10 AC Performance: ADC3422 .....	11	<b>13 Device and Documentation Support</b> .....	<b>49</b>
7.11 AC Performance: ADC3423 .....	13	13.1 Related Links .....	49
7.12 AC Performance: ADC3424 .....	15	13.2 Trademarks .....	49
7.13 Digital Characteristics .....	17	13.3 Electrostatic Discharge Caution .....	49
7.14 Timing Requirements: General .....	17	13.4 Glossary .....	49
7.15 Timing Requirements: LVDS Output .....	18	<b>14 Mechanical, Packaging, and Orderable Information</b> .....	<b>49</b>
7.16 Typical Characteristics .....	19		

## 4 Revision History

DATE	REVISION	NOTES
July 2014	*	Initial release.

### 5 Device Comparison Table

INTERFACE	RESOLUTION (Bits)	25 MSPS	50 MSPS	80 MSPS	125 MSPS	160 MSPS
Serial LVDS	12	ADC3421	ADC3422	ADC3423	ADC3424	—
	14	ADC3441	ADC3442	ADC3443	ADC3444	—
JESD204B	12	—	ADC34J22	ADC34J23	ADC34J24	ADC34J25
	14	—	ADC34J42	ADC34J43	ADC34J44	ADC34J45

### 6 Pin Configuration and Functions

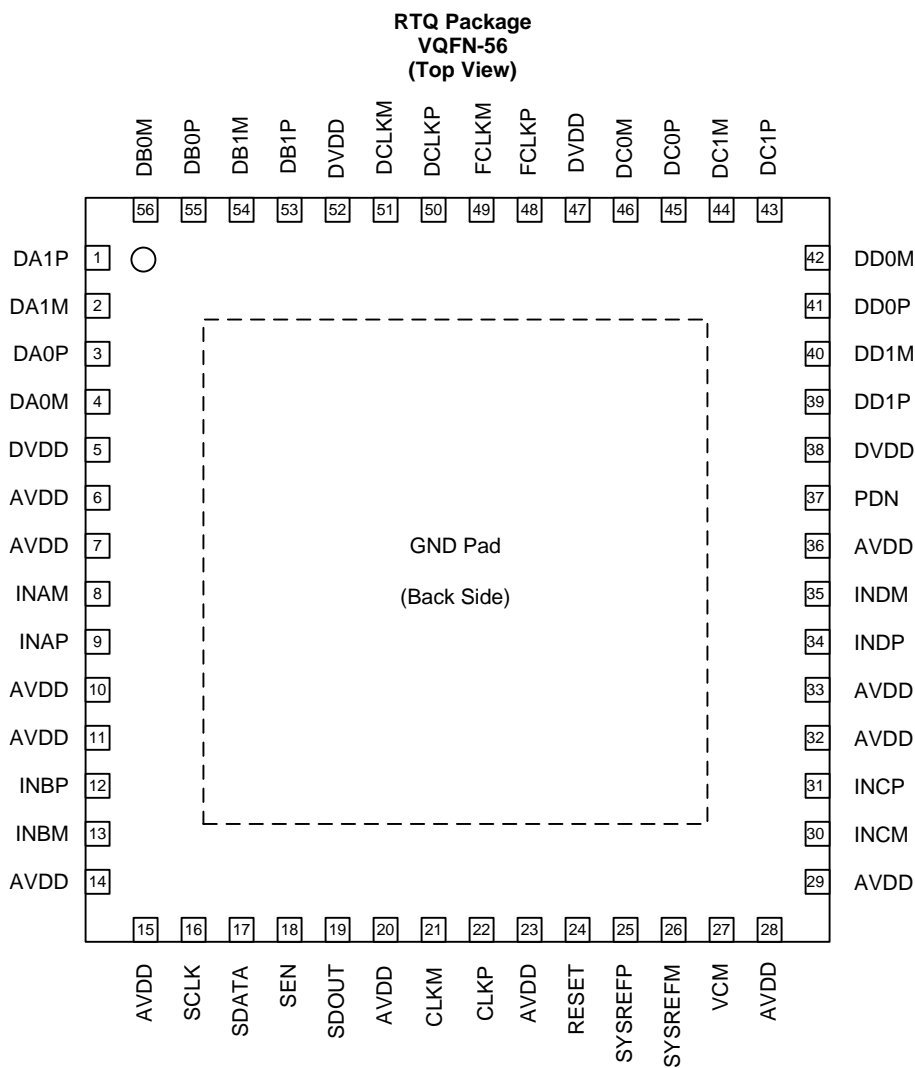

**PRODUCT PREVIEW**

**Pin Functions**

PIN		I/O	DESCRIPTION
NAME	NO.		
AVDD	6, 7, 10, 11, 14, 15, 20, 23, 28, 29, 32, 33, 36	I	Analog 1.8-V power supply
CLKM	21	I	Negative differential clock input for the ADC
CLKP	22	I	Positive differential clock input for the ADC
DA0M	4	O	Negative serial LVDS output for channel A0
DA0P	3	O	Positive serial LVDS output for channel A0
DA1M	2	O	Negative serial LVDS output for channel A1
DA1P	1	O	Positive serial LVDS output for channel A1
DB0M	56	O	Negative serial LVDS output for channel B0
DB0P	55	O	Positive serial LVDS output for channel B0
DB1M	54	O	Negative serial LVDS output for channel B1
DB1P	53	O	Positive serial LVDS output for channel B1
DC0M	46	O	Negative serial LVDS output for channel C0
DC0P	45	O	Positive serial LVDS output for channel C0
DC1M	44	O	Negative serial LVDS output for channel C1
DC1P	43	O	Positive serial LVDS output for channel C1
DD0M	42	O	Negative serial LVDS output for channel D0
DD0P	41	O	Positive serial LVDS output for channel D0
DD1M	40	O	Negative serial LVDS output for channel D1
DD1P	39	O	Positive serial LVDS output for channel D1
DCLKM	51	O	Negative bit clock output
DCLKP	50	O	Positive bit clock output
DVDD	5, 38, 47, 52	I	Digital 1.8-V power supply
FCLKM	49	O	Negative frame clock output
FCLKP	48	O	Positive frame clock output
GND	PowerPAD™	I	Ground, 0 V
INAM	8	I	Negative differential analog input for channel A
INAP	9	I	Positive differential analog input for channel A
INBM	13	I	Negative differential analog input for channel B
INBP	12	I	Positive differential analog input for channel B
INCM	30	I	Negative differential analog input for channel C
INCP	31	I	Positive differential analog input for channel C
INDM	35	I	Negative differential analog input for channel D
INDP	34	I	Positive differential analog input for channel D
PDN	37	I	Power-down control. This pin can be configured via the SPI. This pin has an internal 150-kΩ pull-down resistor.
RESET	24	I	Hardware reset; active high. This pin has an internal 150-kΩ pull-down resistor.
SCLK	16	I	Serial interface clock input. This pin has an internal 150-kΩ pull-down resistor.
SDATA	17	I	Serial interface data input. This pin has an internal 150-kΩ pull-down resistor.
SDOUT	19	O	Serial interface data output
SEN	18	I	Serial interface enable; active low. This pin has an internal 150-kΩ pull-up resistor to AVDD.
SYSREFM	26	I	Negative external SYSREF input
SYSREFP	25	I	Positive external SYSREF input
VCM	27	O	Common-mode voltage for analog inputs

## 7 Specifications

### 7.1 Absolute Maximum Ratings

over operating free-air temperature range (unless otherwise noted)<sup>(1)</sup>

		MIN	MAX	UNIT
Analog supply voltage range, AVDD		-0.3	2.1	V
Digital supply voltage range, DVDD		-0.3	2.1	V
Voltage applied to input pins:	INAP, INBP, INAM, INBM	-0.3	min (1.9, AVDD + 0.3)	V
	CLKP, CLKM	-0.3	AVDD + 0.3	V
	SYSREFP, SYSREFM	-0.3	AVDD + 0.3	V
	SCLK, SEN, SDATA, RESET, PDN	-0.3	3.9	V
Temperature range	Operating free-air, T <sub>A</sub>	-40	85	°C
	Operating junction, T <sub>J</sub>		125	°C

- (1) Stresses beyond those listed under *Absolute Maximum Ratings* may cause permanent damage to the device. These are stress ratings only, which do not imply functional operation of the device at these or any other conditions beyond those indicated under *Recommended Operating Conditions*. Exposure to absolute-maximum-rated conditions for extended periods may affect device reliability.

### 7.2 Handling Ratings

			MIN	MAX	UNIT
T <sub>stg</sub>	Storage temperature range		-65	150	°C
V <sub>(ESD)</sub>	Electrostatic discharge	Human body model (HBM), per ANSI/ESDA/JEDEC JS-001, all pins <sup>(1)</sup>	-2	2	kV

- (1) JEDEC document JEP155 states that 500-V HBM allows safe manufacturing with a standard ESD control process.

### 7.3 Recommended Operating Conditions

over operating free-air temperature range (unless otherwise noted)

		MIN	NOM	MAX	UNIT
<b>SUPPLIES</b>					
AVDD	Analog supply voltage range	1.7	1.8	1.9	V
DVDD	Digital supply voltage range	1.7	1.8	1.9	V
<b>ANALOG INPUT</b>					
V <sub>ID</sub>	Differential input voltage	For input frequencies < 450 MHz		2	V <sub>PP</sub>
		For input frequencies < 600 MHz		1	V <sub>PP</sub>
V <sub>IC</sub>	Input common-mode voltage	VCM ± 0.025			V
<b>CLOCK INPUT</b>					
Input clock frequency		Sampling clock frequency		10	125 <sup>(1)</sup>
Input clock amplitude (differential)		Sine wave, ac-coupled		1.5	V
		LPECL, ac-coupled		1.6	V
		LVDS, ac-coupled		0.7	V
Input clock duty cycle				50%	
Input clock common-mode voltage				0.95	V
<b>DIGITAL OUTPUTS</b>					
C <sub>LOAD</sub>	Maximum external load capacitance from each output pin to GND			3.3	pF
R <sub>LOAD</sub>	Single-ended load resistance			100	Ω

- (1) With the clock divider enabled by default for divide-by-1. Maximum sampling clock frequency for the divide-by-4 option is 500 MSPS.

## 7.4 Thermal Information

THERMAL METRIC <sup>(1)</sup>		ADC342x	UNIT
		RTQ (VQFN)	
		56 PINS	
$R_{\theta JA}$	Junction-to-ambient thermal resistance	25.3	°C/W
$R_{\theta JC(top)}$	Junction-to-case (top) thermal resistance	9.5	
$R_{\theta JB}$	Junction-to-board thermal resistance	3.4	
$\Psi_{JT}$	Junction-to-top characterization parameter	0.2	
$\Psi_{JB}$	Junction-to-board characterization parameter	3.3	
$R_{\theta JC(bot)}$	Junction-to-case (bottom) thermal resistance	0.5	

(1) For more information about traditional and new thermal metrics, see the *IC Package Thermal Metrics* application report, [SPRA953](#).

## 7.5 Performance Modes

over operating free-air temperature range (unless otherwise noted)

MODE	REGISTER SETTINGS	DESCRIPTION
Special modes	Registers 139 (bit 3), 239 (bit 3), 439 (bit 3), and 539 (bit 3)	Always write 1 for best performance
Disable dither	Registers 1 (bits 7:0), 134 (bits 5 and 3), 234 (bits 5 and 3), 434 (bits 5 and 3), and 534 (bits 5 and 3)	Disable dither to improve SNR
Disable chopper	Registers 122 (bit 1), 222 (bit 1), 422 (bit 1), and 522 (bit 1)	Disable chopper to shift 1/f noise floor at dc

## 7.6 Electrical Characteristics: ADC3421, ADC3422

Typical values are over the operating free-air temperature range, at  $T_A = 25^\circ\text{C}$ , full temperature range is  $T_{\text{MIN}} = -40^\circ\text{C}$  to  $T_{\text{MAX}} = 85^\circ\text{C}$ , maximum sampling rate, 50% clock duty cycle,  $\text{AVDD} = \text{DVDD} = 1.8\text{ V}$ , and  $-1\text{-dBFS}$  differential input, unless otherwise noted.

PARAMETER	ADC3421			ADC3422			UNIT
	MIN	TYP	MAX	MIN	TYP	MAX	
ADC clock frequency			25			50	MSPS
Resolution	14			14			Bits
1.8-V analog supply current		54			71		mA
1.8-V digital supply current		45			56		mA
Total power dissipation		177			228		mW
Global power-down dissipation		5			5		mW
Wake-up time from global power-down		85			85		us
Standby power-down dissipation		34			35		mW
Wake-up time from standby power-down		35			35		μs

## 7.7 Electrical Characteristics: ADC3423, ADC3424

Typical values are over the operating free-air temperature range, at  $T_A = 25^\circ\text{C}$ , full temperature range is  $T_{\text{MIN}} = -40^\circ\text{C}$  to  $T_{\text{MAX}} = 85^\circ\text{C}$ , maximum sampling rate, 50% clock duty cycle,  $\text{AVDD} = \text{DVDD} = 1.8\text{ V}$ , and  $-1\text{-dBFS}$  differential input, unless otherwise noted.

PARAMETER	ADC3423			ADC3424			UNIT
	MIN	TYP	MAX	MIN	TYP	MAX	
ADC clock frequency			80			125	MSPS
Resolution	14			14			Bits
1.8-V analog supply current		92			119		mA
1.8-V digital supply current		68			98		mA
Total power dissipation		288			391		mW
Global power-down dissipation		5			5		mW
Wake-up time from global power-down		85			85		us
Standby power-down dissipation		40			43		mW
Wake-up time from standby power-down		35			35		μs

## 7.8 Electrical Characteristics: General

Typical values are over the operating free-air temperature range, at  $T_A = 25^\circ\text{C}$ , full temperature range is  $T_{\text{MIN}} = -40^\circ\text{C}$  to  $T_{\text{MAX}} = 85^\circ\text{C}$ , maximum sampling rate, 50% clock duty cycle,  $\text{AVDD} = \text{DVDD} = 1.8\text{ V}$ , and  $-1\text{-dBFS}$  differential input, unless otherwise noted.

PARAMETER	TEST CONDITIONS	MIN	TYP	MAX	UNIT
<b>ANALOG INPUT</b>					
	Differential input full-scale		2.0		$V_{\text{PP}}$
$r_i$	Input resistance	Differential at dc	6.6		$\text{k}\Omega$
$c_i$	Input capacitance	Differential at dc	3.7		$\text{pF}$
$V_{\text{OC(VCM)}}$	VCM common-mode voltage output		0.95		V
	VCM output current capability		10		mA
	Input common-mode current	Per analog input pin	1.5		$\mu\text{A/MSPS}$
	Analog input bandwidth (3 dB)	50- $\Omega$ differential source driving 50- $\Omega$ termination across INP and INM	540		MHz
<b>DC ACCURACY</b>					
$E_{\text{O}}$	Offset error		-TBD	TBD	mV
$\alpha_{\text{EO}}$	Temperature coefficient of offset error		TBD		mV/C
$E_{\text{G(REF)}}$	Gain error as a result of internal reference inaccuracy alone		-TBD	TBD	%FS
$E_{\text{G(CHAN)}}$	Gain error of channel alone		1.5		%FS
$\alpha_{\text{(EGCHAN)}}$	Temperature coefficient of $E_{\text{G(CHAN)}}$		TBD		$\Delta\%FS/\text{Ch}$
<b>CHANNEL-TO-CHANNEL ISOLATION</b>					
Crosstalk <sup>(1)</sup>	$f_{\text{IN}} = 10\text{ MHz}$	Near channel		105	dB
		Far channel		105	dB
	$f_{\text{IN}} = 100\text{ MHz}$	Near channel		95	dB
		Far channel		105	dB
	$f_{\text{IN}} = 200\text{ MHz}$	Near channel		94	dB
		Far channel		105	dB
	$f_{\text{IN}} = 230\text{ MHz}$	Near channel		92	dB
		Far channel		105	dB
	$f_{\text{IN}} = 300\text{ MHz}$	Near channel		85	dB
		Far channel		105	dB

(1) Crosstalk is measured with a  $-1\text{-dBFS}$  input signal on the aggressor channel and no input on the victim channel.

## 7.9 AC Performance: ADC3421

Typical values are over the operating free-air temperature range, at  $T_A = 25^\circ\text{C}$ , full temperature range is  $T_{\text{MIN}} = -40^\circ\text{C}$  to  $T_{\text{MAX}} = 85^\circ\text{C}$ , ADC sampling rate = 25 MSPS, 50% clock duty cycle, AVDD = DVDD = 1.8 V, and –1-dBFS differential input, unless otherwise noted.

PARAMETER	TEST CONDITIONS	ADC3421 ( $f_s = 25$ MSPS)						UNIT	
		DITHER ON			DITHER OFF				
		MIN	TYP	MAX	MIN	TYP	MAX		
<b>DYNAMIC AC CHARACTERISTICS</b>									
SNR	Signal-to-noise ratio (from 1-MHz offset)	$f_{\text{IN}} = 10$ MHz	71			71.1			dBFS
		$f_{\text{IN}} = 20$ MHz	TBD	70.9		71.1			
		$f_{\text{IN}} = 20$ MHz, $T_A = 25^\circ\text{C}$	TBD	70.9		71.1			
		$f_{\text{IN}} = 70$ MHz	70.9			71			
		$f_{\text{IN}} = 100$ MHz	70.6			70.7			
		$f_{\text{IN}} = 170$ MHz	69.5			69.7			
		$f_{\text{IN}} = 230$ MHz	69.1			69.2			
	Signal-to-noise ratio (full Nyquist band)	$f_{\text{IN}} = 10$ MHz	70.3			70.5			
		$f_{\text{IN}} = 20$ MHz	70.3			70.5			
		$f_{\text{IN}} = 20$ MHz, $T_A = 25^\circ\text{C}$	70.3			70.5			
		$f_{\text{IN}} = 70$ MHz	70.3			70.4			
		$f_{\text{IN}} = 100$ MHz	70			70.2			
		$f_{\text{IN}} = 170$ MHz	69			69.1			
		$f_{\text{IN}} = 230$ MHz	68.5			68.6			
NSD <sup>(1)</sup>	Noise spectral density (averaged across Nyquist zone)	$f_{\text{IN}} = 10$ MHz	–142			–142.1			dBFS/Hz
		$f_{\text{IN}} = 20$ MHz	TBD	–141.9		–142.1			
		$f_{\text{IN}} = 20$ MHz, $T_A = 25^\circ\text{C}$	TBD	–141.9		–142.1			
		$f_{\text{IN}} = 70$ MHz	–141.9			–142			
		$f_{\text{IN}} = 100$ MHz	–141.6			–141.7			
		$f_{\text{IN}} = 170$ MHz	–140.5			–140.7			
		$f_{\text{IN}} = 230$ MHz	–140.1			–140.2			
SINAD <sup>(1)</sup>	Signal-to-noise and distortion ratio	$f_{\text{IN}} = 10$ MHz	71			71			dBFS
		$f_{\text{IN}} = 20$ MHz	TBD	70.9		71			
		$f_{\text{IN}} = 20$ MHz, $T_A = 25^\circ\text{C}$	TBD	70.9		71			
		$f_{\text{IN}} = 70$ MHz	70.8			70.9			
		$f_{\text{IN}} = 100$ MHz	70.5			70.5			
		$f_{\text{IN}} = 170$ MHz	69.4			69.5			
		$f_{\text{IN}} = 230$ MHz	68.9			68.8			
ENOB <sup>(1)</sup>	Effective number of bits	$f_{\text{IN}} = 10$ MHz	11.5			11.5			Bits
		$f_{\text{IN}} = 20$ MHz	TBD	11.5		11.5			
		$f_{\text{IN}} = 20$ MHz, $T_A = 25^\circ\text{C}$	TBD	11.5		11.5			
		$f_{\text{IN}} = 70$ MHz	11.5			11.5			
		$f_{\text{IN}} = 100$ MHz	11.4			11.4			
		$f_{\text{IN}} = 170$ MHz	11.2			11.3			
		$f_{\text{IN}} = 230$ MHz	11.2			11.1			

(1) Reported from 1-MHz offset.

**AC Performance: ADC3421 (continued)**

Typical values are over the operating free-air temperature range, at  $T_A = 25^\circ\text{C}$ , full temperature range is  $T_{\text{MIN}} = -40^\circ\text{C}$  to  $T_{\text{MAX}} = 85^\circ\text{C}$ , ADC sampling rate = 25 MSPS, 50% clock duty cycle, AVDD = DVDD = 1.8 V, and –1-dBFS differential input, unless otherwise noted.

PARAMETER	TEST CONDITIONS	ADC3421 ( $f_s = 25$ MSPS)						UNIT
		DITHER ON			DITHER OFF			
		MIN	TYP	MAX	MIN	TYP	MAX	
SFDR	Spurious-free dynamic range	$f_{\text{IN}} = 10$ MHz		93		90		dBc
		$f_{\text{IN}} = 20$ MHz	TBD	92		89		
		$f_{\text{IN}} = 20$ MHz, $T_A = 25^\circ\text{C}$	TBD	92		89		
		$f_{\text{IN}} = 70$ MHz		90		88		
		$f_{\text{IN}} = 100$ MHz		89		86		
		$f_{\text{IN}} = 170$ MHz		85		83		
		$f_{\text{IN}} = 230$ MHz		83		80		
HD2	Second harmonic distortion	$f_{\text{IN}} = 10$ MHz		99		95		dBc
		$f_{\text{IN}} = 20$ MHz	TBD	95		91		
		$f_{\text{IN}} = 20$ MHz, $T_A = 25^\circ\text{C}$	TBD	95		91		
		$f_{\text{IN}} = 70$ MHz		92		90		
		$f_{\text{IN}} = 100$ MHz		90		87		
		$f_{\text{IN}} = 170$ MHz		87		85		
		$f_{\text{IN}} = 230$ MHz		83		81		
HD3	Third harmonic distortion	$f_{\text{IN}} = 10$ MHz		93		90		dBc
		$f_{\text{IN}} = 20$ MHz	TBD	92		89		
		$f_{\text{IN}} = 20$ MHz, $T_A = 25^\circ\text{C}$	TBD	92		89		
		$f_{\text{IN}} = 70$ MHz		90		88		
		$f_{\text{IN}} = 100$ MHz		89		86		
		$f_{\text{IN}} = 170$ MHz		85		83		
		$f_{\text{IN}} = 230$ MHz		83		80		
Non HD2, HD3	Spurious-free dynamic range (excluding HD2, HD3)	$f_{\text{IN}} = 10$ MHz		98		97		dBc
		$f_{\text{IN}} = 20$ MHz	TBD	97		95		
		$f_{\text{IN}} = 20$ MHz, $T_A = 25^\circ\text{C}$	TBD	97		95		
		$f_{\text{IN}} = 70$ MHz		96		95		
		$f_{\text{IN}} = 100$ MHz		96		95		
		$f_{\text{IN}} = 170$ MHz		96		94		
		$f_{\text{IN}} = 230$ MHz		94		92		
THD	Total harmonic distortion	$f_{\text{IN}} = 10$ MHz		92		89		dBc
		$f_{\text{IN}} = 20$ MHz	TBD	90		87		
		$f_{\text{IN}} = 20$ MHz, $T_A = 25^\circ\text{C}$	TBD	90		87		
		$f_{\text{IN}} = 70$ MHz		88		86		
		$f_{\text{IN}} = 100$ MHz		87		84		
		$f_{\text{IN}} = 170$ MHz		84		82		
		$f_{\text{IN}} = 230$ MHz		81		78		
IMD3	Third-tone intermodulation distortion	$f_{\text{IN1}} = 45$ MHz, $f_{\text{IN2}} = 50$ MHz		94		95		dBFS
		$f_{\text{IN1}} = 185$ MHz, $f_{\text{IN2}} = 190$ MHz		89		88		

## 7.10 AC Performance: ADC3422

Typical values are over the operating free-air temperature range, at  $T_A = 25^\circ\text{C}$ , full temperature range is  $T_{\text{MIN}} = -40^\circ\text{C}$  to  $T_{\text{MAX}} = 85^\circ\text{C}$ , ADC sampling rate = 50 MSPS, 50% clock duty cycle, AVDD = DVDD = 1.8 V, and –1-dBFS differential input, unless otherwise noted.

PARAMETER	TEST CONDITIONS	ADC3422 ( $f_s = 50$ MSPS)						UNIT	
		DITHER ON			DITHER OFF				
		MIN	TYP	MAX	MIN	TYP	MAX		
<b>DYNAMIC AC CHARACTERISTICS</b>									
SNR	Signal-to-noise ratio (from 1-MHz offset)	$f_{\text{IN}} = 10$ MHz	70.9			71			dBFS
		$f_{\text{IN}} = 20$ MHz	TBD	70.8		70.9			
		$f_{\text{IN}} = 20$ MHz, $T_A = 25^\circ\text{C}$	TBD	70.8		70.9			
		$f_{\text{IN}} = 70$ MHz	70.6			70.7			
		$f_{\text{IN}} = 100$ MHz	70.5			70.6			
		$f_{\text{IN}} = 170$ MHz	69.7			69.8			
		$f_{\text{IN}} = 230$ MHz	69.5			69.5			
	Signal-to-noise ratio (full Nyquist band)	$f_{\text{IN}} = 10$ MHz	70.4			70.5			
		$f_{\text{IN}} = 20$ MHz	70.4			70.5			
		$f_{\text{IN}} = 20$ MHz, $T_A = 25^\circ\text{C}$	70.4			70.5			
		$f_{\text{IN}} = 70$ MHz	70.2			70.3			
		$f_{\text{IN}} = 100$ MHz	70.1			70.2			
		$f_{\text{IN}} = 170$ MHz	69.3			69.4			
		$f_{\text{IN}} = 230$ MHz	69.1			69.1			
NSD <sup>(1)</sup>	Noise spectral density (averaged across Nyquist zone)	$f_{\text{IN}} = 10$ MHz	–144.9			–145			dBFS/Hz
		$f_{\text{IN}} = 20$ MHz	TBD	–144.8		–144.9			
		$f_{\text{IN}} = 20$ MHz, $T_A = 25^\circ\text{C}$	TBD	–144.6		–144.7			
		$f_{\text{IN}} = 70$ MHz	–144.5			–144.6			
		$f_{\text{IN}} = 100$ MHz	–143.7			–143.8			
		$f_{\text{IN}} = 170$ MHz	–143.5			–143.5			
		$f_{\text{IN}} = 230$ MHz	–144.4			–144.5			
SINAD <sup>(1)</sup>	Signal-to-noise and distortion ratio	$f_{\text{IN}} = 10$ MHz	70.8			70.9			dBFS
		$f_{\text{IN}} = 20$ MHz	TBD	70.7		70.8			
		$f_{\text{IN}} = 20$ MHz, $T_A = 25^\circ\text{C}$	TBD	70.5		70.5			
		$f_{\text{IN}} = 70$ MHz	70.3			70.1			
		$f_{\text{IN}} = 100$ MHz	69.5			69.5			
		$f_{\text{IN}} = 170$ MHz	69.5			69.5			
		$f_{\text{IN}} = 230$ MHz	69.2			69.2			
ENOB <sup>(1)</sup>	Effective number of bits	$f_{\text{IN}} = 10$ MHz	11.5			11.5			Bits
		$f_{\text{IN}} = 20$ MHz	TBD	11.5		11.5			
		$f_{\text{IN}} = 20$ MHz, $T_A = 25^\circ\text{C}$	TBD	11.4		11.4			
		$f_{\text{IN}} = 70$ MHz	11.4			11.4			
		$f_{\text{IN}} = 100$ MHz	11.3			11.3			
		$f_{\text{IN}} = 170$ MHz	11.3			11.3			
		$f_{\text{IN}} = 230$ MHz	11.2			11.2			

(1) Reported from 1-MHz offset.

**AC Performance: ADC3422 (continued)**

Typical values are over the operating free-air temperature range, at  $T_A = 25^\circ\text{C}$ , full temperature range is  $T_{\text{MIN}} = -40^\circ\text{C}$  to  $T_{\text{MAX}} = 85^\circ\text{C}$ , ADC sampling rate = 50 MSPS, 50% clock duty cycle, AVDD = DVDD = 1.8 V, and –1-dBFS differential input, unless otherwise noted.

PARAMETER	TEST CONDITIONS	ADC3422 ( $f_s = 50$ MSPS)						UNIT
		DITHER ON			DITHER OFF			
		MIN	TYP	MAX	MIN	TYP	MAX	
SFDR	Spurious-free dynamic range	$f_{\text{IN}} = 10$ MHz		90			89	dBc
		$f_{\text{IN}} = 20$ MHz	TBD	90			89	
		$f_{\text{IN}} = 20$ MHz, $T_A = 25^\circ\text{C}$	TBD	90			89	
		$f_{\text{IN}} = 70$ MHz		90			87	
		$f_{\text{IN}} = 100$ MHz		89			87	
		$f_{\text{IN}} = 170$ MHz		86			83	
		$f_{\text{IN}} = 230$ MHz		83			80	
HD2	Second harmonic distortion	$f_{\text{IN}} = 10$ MHz		100			94	dBc
		$f_{\text{IN}} = 20$ MHz	TBD	97			93	
		$f_{\text{IN}} = 20$ MHz, $T_A = 25^\circ\text{C}$	TBD	97			93	
		$f_{\text{IN}} = 70$ MHz		92			89	
		$f_{\text{IN}} = 100$ MHz		92			88	
		$f_{\text{IN}} = 170$ MHz		88			86	
		$f_{\text{IN}} = 230$ MHz		84			80	
HD3	Third harmonic distortion	$f_{\text{IN}} = 10$ MHz		90			89	dBc
		$f_{\text{IN}} = 20$ MHz	TBD	90			89	
		$f_{\text{IN}} = 20$ MHz, $T_A = 25^\circ\text{C}$	TBD	90			89	
		$f_{\text{IN}} = 70$ MHz		90			87	
		$f_{\text{IN}} = 100$ MHz		89			87	
		$f_{\text{IN}} = 170$ MHz		86			83	
		$f_{\text{IN}} = 230$ MHz		83			80	
Non HD2, HD3	Spurious-free dynamic range (excluding HD2, HD3)	$f_{\text{IN}} = 10$ MHz		100			97	dBc
		$f_{\text{IN}} = 20$ MHz	TBD	100			96	
		$f_{\text{IN}} = 20$ MHz, $T_A = 25^\circ\text{C}$	TBD	100			96	
		$f_{\text{IN}} = 70$ MHz		97			94	
		$f_{\text{IN}} = 100$ MHz		96			94	
		$f_{\text{IN}} = 170$ MHz		96			92	
		$f_{\text{IN}} = 230$ MHz		95			92	
THD	Total harmonic distortion	$f_{\text{IN}} = 10$ MHz		89			87	dBc
		$f_{\text{IN}} = 20$ MHz	TBD	89			85	
		$f_{\text{IN}} = 20$ MHz, $T_A = 25^\circ\text{C}$	TBD	86			84	
		$f_{\text{IN}} = 70$ MHz		83			79	
		$f_{\text{IN}} = 100$ MHz		83			80	
		$f_{\text{IN}} = 170$ MHz		89			88	
		$f_{\text{IN}} = 230$ MHz		80			80	
IMD3	Third-tone intermodulation distortion	$f_{\text{IN1}} = 45$ MHz, $f_{\text{IN2}} = 50$ MHz		93			93	dBFS
		$f_{\text{IN1}} = 185$ MHz, $f_{\text{IN2}} = 190$ MHz		91			89	

## 7.11 AC Performance: ADC3423

Typical values are over the operating free-air temperature range, at  $T_A = 25^\circ\text{C}$ , full temperature range is  $T_{\text{MIN}} = -40^\circ\text{C}$  to  $T_{\text{MAX}} = 85^\circ\text{C}$ , ADC sampling rate = 80 MSPS, 50% clock duty cycle, AVDD = DVDD = 1.8 V, and –1-dBFS differential input, unless otherwise noted.

PARAMETER		TEST CONDITIONS	ADC3423 ( $f_s = 80$ MSPS)						UNIT
			DITHER ON			DITHER OFF			
			MIN	TYP	MAX	MIN	TYP	MAX	
<b>DYNAMIC AC CHARACTERISTICS</b>									
SNR	Signal-to-noise ratio (from 1-MHz offset)	$f_{\text{IN}} = 10$ MHz	70.6			70.8			dBFS
		$f_{\text{IN}} = 70$ MHz	TBD	70.2		70.3			
		$f_{\text{IN}} = 70$ MHz, $T_A = 25^\circ\text{C}$	TBD	70.2		70.3			
		$f_{\text{IN}} = 100$ MHz	70.1			70.2			
		$f_{\text{IN}} = 170$ MHz	69.6			69.8			
		$f_{\text{IN}} = 230$ MHz	69.1			69.3			
	Signal-to-noise ratio (full Nyquist band)	$f_{\text{IN}} = 10$ MHz	70.2			70.4			
		$f_{\text{IN}} = 70$ MHz	69.8			70			
		$f_{\text{IN}} = 70$ MHz, $T_A = 25^\circ\text{C}$	69.8			70			
		$f_{\text{IN}} = 100$ MHz	69.7			69.9			
		$f_{\text{IN}} = 170$ MHz	69.2			69.4			
		$f_{\text{IN}} = 230$ MHz	68.8			69			
NSD <sup>(1)</sup>	Noise spectral density (averaged across Nyquist zone)	$f_{\text{IN}} = 10$ MHz	–146.6			–146.8			dBFS/Hz
		$f_{\text{IN}} = 70$ MHz	TBD	–146.2		–146.3			
		$f_{\text{IN}} = 70$ MHz, $T_A = 25^\circ\text{C}$	TBD	–146.2		–146.3			
		$f_{\text{IN}} = 100$ MHz	–146.1			–146.2			
		$f_{\text{IN}} = 170$ MHz	–145.6			–145.8			
		$f_{\text{IN}} = 230$ MHz	–145.1			–145.3			
SINAD <sup>(1)</sup>	Signal-to-noise and distortion ratio	$f_{\text{IN}} = 10$ MHz	70.6			70.7			dBFS
		$f_{\text{IN}} = 70$ MHz	TBD	70.2		70.2			
		$f_{\text{IN}} = 70$ MHz, $T_A = 25^\circ\text{C}$	TBD	70.2		70.2			
		$f_{\text{IN}} = 100$ MHz	70			70.1			
		$f_{\text{IN}} = 170$ MHz	69.5			69.6			
		$f_{\text{IN}} = 230$ MHz	68.9			68.9			
ENOB <sup>(1)</sup>	Effective number of bits	$f_{\text{IN}} = 10$ MHz	11.4			11.5			Bits
		$f_{\text{IN}} = 70$ MHz	TBD	11.4		11.4			
		$f_{\text{IN}} = 70$ MHz, $T_A = 25^\circ\text{C}$	TBD	11.4		11.4			
		$f_{\text{IN}} = 100$ MHz	11.3			11.4			
		$f_{\text{IN}} = 170$ MHz	11.3			11.3			
		$f_{\text{IN}} = 230$ MHz	11.2			11.2			
SFDR	Spurious-free dynamic range	$f_{\text{IN}} = 10$ MHz	93			90			dBc
		$f_{\text{IN}} = 70$ MHz	TBD	90		87			
		$f_{\text{IN}} = 70$ MHz, $T_A = 25^\circ\text{C}$	TBD	90		87			
		$f_{\text{IN}} = 100$ MHz	89			86			
		$f_{\text{IN}} = 170$ MHz	87			83			
		$f_{\text{IN}} = 230$ MHz	83			81			

(1) Reported from 1-MHz offset.

**AC Performance: ADC3423 (continued)**

Typical values are over the operating free-air temperature range, at  $T_A = 25^\circ\text{C}$ , full temperature range is  $T_{\text{MIN}} = -40^\circ\text{C}$  to  $T_{\text{MAX}} = 85^\circ\text{C}$ , ADC sampling rate = 80 MSPS, 50% clock duty cycle, AVDD = DVDD = 1.8 V, and –1-dBFS differential input, unless otherwise noted.

PARAMETER	TEST CONDITIONS	ADC3423 ( $f_s = 80$ MSPS)						UNIT
		DITHER ON			DITHER OFF			
		MIN	TYP	MAX	MIN	TYP	MAX	
HD2	Second harmonic distortion	$f_{\text{IN}} = 10$ MHz		101		95		dBc
		$f_{\text{IN}} = 70$ MHz	TBD	97		92		
		$f_{\text{IN}} = 70$ MHz, $T_A = 25^\circ\text{C}$	TBD	97		92		
		$f_{\text{IN}} = 100$ MHz		93		89		
		$f_{\text{IN}} = 170$ MHz		88		85		
		$f_{\text{IN}} = 230$ MHz		83		81		
HD3	Third harmonic distortion	$f_{\text{IN}} = 10$ MHz		93		90		dBc
		$f_{\text{IN}} = 70$ MHz	TBD	90		87		
		$f_{\text{IN}} = 70$ MHz, $T_A = 25^\circ\text{C}$	TBD	90		87		
		$f_{\text{IN}} = 100$ MHz		89		86		
		$f_{\text{IN}} = 170$ MHz		87		83		
		$f_{\text{IN}} = 230$ MHz		86		81		
Non HD2, HD3	Spurious-free dynamic range (excluding HD2, HD3)	$f_{\text{IN}} = 10$ MHz		99		95		dBc
		$f_{\text{IN}} = 70$ MHz	TBD	97		94		
		$f_{\text{IN}} = 70$ MHz, $T_A = 25^\circ\text{C}$	TBD	97		94		
		$f_{\text{IN}} = 100$ MHz		96		94		
		$f_{\text{IN}} = 170$ MHz		96		94		
		$f_{\text{IN}} = 230$ MHz		96		93		
THD	Total harmonic distortion	$f_{\text{IN}} = 10$ MHz		93		89		dBc
		$f_{\text{IN}} = 70$ MHz	TBD	90		86		
		$f_{\text{IN}} = 70$ MHz, $T_A = 25^\circ\text{C}$	TBD	90		86		
		$f_{\text{IN}} = 100$ MHz		88		85		
		$f_{\text{IN}} = 170$ MHz		85		82		
		$f_{\text{IN}} = 230$ MHz		82		79		
IMD3	Third tone intermodulation distortion	$f_{\text{IN1}} = 45$ MHz, $f_{\text{IN2}} = 50$ MHz		95		95		dBFS
		$f_{\text{IN1}} = 185$ MHz, $f_{\text{IN2}} = 190$ MHz		89		88		

## 7.12 AC Performance: ADC3424

Typical values are over the operating free-air temperature range, at  $T_A = 25^\circ\text{C}$ , full temperature range is  $T_{\text{MIN}} = -40^\circ\text{C}$  to  $T_{\text{MAX}} = 85^\circ\text{C}$ , ADC sampling rate = 125 MSPS, 50% clock duty cycle,  $\text{AVDD} = \text{DVDD} = 1.8\text{ V}$ , and  $-1\text{-dBFS}$  differential input, unless otherwise noted.

PARAMETER		TEST CONDITIONS	ADC3424 ( $f_s = 125\text{ MSPS}$ )						UNIT
			DITHER ON			DITHER OFF			
			MIN	TYP	MAX	MIN	TYP	MAX	
<b>DYNAMIC AC CHARACTERISTICS</b>									
SNR	Signal-to-noise ratio (from 1-MHz offset)	$f_{\text{IN}} = 10\text{ MHz}$	70.4			70.6			dBFS
		$f_{\text{IN}} = 70\text{ MHz}$	TBD	70.2		70.4			
		$f_{\text{IN}} = 70\text{ MHz}, T_A = 25^\circ\text{C}$	TBD	70.2		70.4			
		$f_{\text{IN}} = 100\text{ MHz}$	70			70.2			
		$f_{\text{IN}} = 170\text{ MHz}$	69.5			69.9			
		$f_{\text{IN}} = 230\text{ MHz}$	69.2			69.5			
	Signal-to-noise ratio (full Nyquist band)	$f_{\text{IN}} = 10\text{ MHz}$	70.2			70.4			
		$f_{\text{IN}} = 70\text{ MHz}$	70			70.2			
		$f_{\text{IN}} = 70\text{ MHz}, T_A = 25^\circ\text{C}$	70			70.2			
		$f_{\text{IN}} = 100\text{ MHz}$	69.9			70			
		$f_{\text{IN}} = 170\text{ MHz}$	69.3			69.7			
		$f_{\text{IN}} = 230\text{ MHz}$	69			69.3			
NSD <sup>(1)</sup>	Noise spectral density (averaged across Nyquist zone)	$f_{\text{IN}} = 10\text{ MHz}$	-148.4			-148.6			dBFS/Hz
		$f_{\text{IN}} = 70\text{ MHz}$	TBD	-148.2		-148.4			
		$f_{\text{IN}} = 70\text{ MHz}, T_A = 25^\circ\text{C}$	TBD	-148.2		-148.4			
		$f_{\text{IN}} = 100\text{ MHz}$	-148			-148.2			
		$f_{\text{IN}} = 170\text{ MHz}$	-147.5			-147.9			
		$f_{\text{IN}} = 230\text{ MHz}$	-147.2			-147.5			
SINAD <sup>(1)</sup>	Signal-to-noise and distortion ratio	$f_{\text{IN}} = 10\text{ MHz}$	70.4			70.5			dBFS
		$f_{\text{IN}} = 70\text{ MHz}$	TBD	70.1		70.3			
		$f_{\text{IN}} = 70\text{ MHz}, T_A = 25^\circ\text{C}$	TBD	70.1		70.3			
		$f_{\text{IN}} = 100\text{ MHz}$	69.9			70			
		$f_{\text{IN}} = 170\text{ MHz}$	69.3			69.6			
		$f_{\text{IN}} = 230\text{ MHz}$	68.9			69			
ENOB <sup>(1)</sup>	Effective number of bits	$f_{\text{IN}} = 10\text{ MHz}$	11.4			11.4			Bits
		$f_{\text{IN}} = 70\text{ MHz}$	TBD	11.3		11.4			
		$f_{\text{IN}} = 70\text{ MHz}, T_A = 25^\circ\text{C}$	TBD	11.3		11.4			
		$f_{\text{IN}} = 100\text{ MHz}$	11.3			11.3			
		$f_{\text{IN}} = 170\text{ MHz}$	11.2			11.3			
		$f_{\text{IN}} = 230\text{ MHz}$	11.1			11.2			
SFDR	Spurious-free dynamic range	$f_{\text{IN}} = 10\text{ MHz}$	93			89			dBc
		$f_{\text{IN}} = 70\text{ MHz}$	TBD	87		85			
		$f_{\text{IN}} = 70\text{ MHz}, T_A = 25^\circ\text{C}$	TBD	87		85			
		$f_{\text{IN}} = 100\text{ MHz}$	86			84			
		$f_{\text{IN}} = 170\text{ MHz}$	84			81			
		$f_{\text{IN}} = 230\text{ MHz}$	82			80			

(1) Reported from 1-MHz offset.

**AC Performance: ADC3424 (continued)**

Typical values are over the operating free-air temperature range, at  $T_A = 25^\circ\text{C}$ , full temperature range is  $T_{\text{MIN}} = -40^\circ\text{C}$  to  $T_{\text{MAX}} = 85^\circ\text{C}$ , ADC sampling rate = 125 MSPS, 50% clock duty cycle, AVDD = DVDD = 1.8 V, and –1-dBFS differential input, unless otherwise noted.

PARAMETER	TEST CONDITIONS	ADC3424 ( $f_s = 125$ MSPS)						UNIT
		DITHER ON			DITHER OFF			
		MIN	TYP	MAX	MIN	TYP	MAX	
HD2	Second harmonic distortion	$f_{\text{IN}} = 10$ MHz		100		94		dBc
		$f_{\text{IN}} = 70$ MHz	TBD	96		91		
		$f_{\text{IN}} = 70$ MHz, $T_A = 25^\circ\text{C}$	TBD	96		91		
		$f_{\text{IN}} = 100$ MHz		91		87		
		$f_{\text{IN}} = 170$ MHz		87		85		
		$f_{\text{IN}} = 230$ MHz		83		80		
HD3	Third harmonic distortion	$f_{\text{IN}} = 10$ MHz		93		89		dBc
		$f_{\text{IN}} = 70$ MHz	TBD	87		85		
		$f_{\text{IN}} = 70$ MHz, $T_A = 25^\circ\text{C}$	TBD	87		85		
		$f_{\text{IN}} = 100$ MHz		86		84		
		$f_{\text{IN}} = 170$ MHz		84		81		
		$f_{\text{IN}} = 230$ MHz		82		80		
Non HD2, HD3	Spurious-free dynamic range (excluding HD2, HD3)	$f_{\text{IN}} = 10$ MHz		98		94		dBc
		$f_{\text{IN}} = 70$ MHz	TBD	97		93		
		$f_{\text{IN}} = 70$ MHz, $T_A = 25^\circ\text{C}$	TBD	97		93		
		$f_{\text{IN}} = 100$ MHz		96		93		
		$f_{\text{IN}} = 170$ MHz		96		92		
		$f_{\text{IN}} = 230$ MHz		96		92		
THD	Total harmonic distortion	$f_{\text{IN}} = 10$ MHz		92		88		dBc
		$f_{\text{IN}} = 70$ MHz	TBD	87		85		
		$f_{\text{IN}} = 70$ MHz, $T_A = 25^\circ\text{C}$	TBD	87		85		
		$f_{\text{IN}} = 100$ MHz		85		83		
		$f_{\text{IN}} = 170$ MHz		83		80		
		$f_{\text{IN}} = 230$ MHz		80		78		
IMD3	Third-tone intermodulation distortion	$f_{\text{IN1}} = 45$ MHz, $f_{\text{IN2}} = 50$ MHz		95		95		dBFS
		$f_{\text{IN1}} = 185$ MHz, $f_{\text{IN2}} = 190$ MHz		87		86		

### 7.13 Digital Characteristics

The dc specifications refer to the condition where the digital outputs are not switching, but are permanently at a valid logic level 0 or 1. AVDD = DVDD = 1.8 V, and –1-dBFS differential input, unless otherwise noted.

PARAMETER		TEST CONDITIONS	MIN	TYP	MAX	UNIT
<b>DIGITAL INPUTS (RESET, SCLK, SDATA, SEN, PDN)</b>						
V <sub>IH</sub>	High-level input voltage	All digital inputs support 1.8-V and 3.3-V CMOS logic levels	1.3			V
V <sub>IL</sub>	Low-level input voltage	All digital inputs support 1.8-V and 3.3-V CMOS logic levels			0.4	V
I <sub>IH</sub>	High-level input current	RESET, SDATA, SCLK, PDN	V <sub>HIGH</sub> = 1.8 V	10		μA
		SEN <sup>(1)</sup>	V <sub>HIGH</sub> = 1.8 V	0		μA
I <sub>IL</sub>	Low-level input current	RESET, SDATA, SCLK, PDN	V <sub>LOW</sub> = 0 V	0		μA
		SEN	V <sub>LOW</sub> = 0 V	10		μA
<b>DIGITAL OUTPUTS, CMOS INTERFACE (SDOUT)</b>						
V <sub>OH</sub>	High-level output voltage		DVDD – 0.1	DVDD		V
V <sub>OL</sub>	Low-level output voltage			0	0.1	V
<b>DIGITAL OUTPUTS, LVDS INTERFACE</b>						
V <sub>ODH</sub>	High-level output differential voltage	With an external 100-Ω termination	TBD	350	TBD	mV
V <sub>ODL</sub>	Low-level output differential voltage	With an external 100-Ω termination	TBD	–350	TBD	mV
V <sub>OCM</sub>	Output common-mode voltage			1.05		V

(1) SEN has an internal 150-kΩ pull-up resistor to AVDD. Because the pull-up resistor is weak, SEN can also be driven by 1.8-V or 3.3-V CMOS buffers.

### 7.14 Timing Requirements: General

Typical values are at T<sub>A</sub> = 25°C, AVDD = DVDD = 1.8 V, and –1-dBFS differential input, unless otherwise noted. Minimum and maximum values are across the full temperature range: T<sub>MIN</sub> = –40°C to T<sub>MAX</sub> = 85°C.

PARAMETER		DESCRIPTION	MIN	TYP	MAX	UNIT
t <sub>A</sub>	Aperture delay		1.24	1.44	1.64	ns
	Aperture delay matching	Between two channels of the same device		±70		ps
	Variation of aperture delay	Between two devices at the same temperature and supply voltage		±150		ps
t <sub>J</sub>	Aperture jitter			130		f <sub>S</sub> rms
	Wake-up time	Time to valid data after coming out of STANDBY mode		35	TBD	μs
		Time to valid data after coming out of GLOBAL power-down mode (in this mode, both channels power down)		85	TBD	μs
	ADC latency <sup>(1)</sup>	Default latency after reset		TBD		Clock cycles
t <sub>SU_SYSREF</sub>	SYSREF reference time	Setup time for SYSREF referenced to input clock rising edge	1000			ps
t <sub>H_SYSREF</sub>		Hold time for SYSREF referenced to input clock rising edge	100			ps

(1) Overall latency = ADC latency + t<sub>PDI</sub>.

## 7.15 Timing Requirements: LVDS Output<sup>(1)</sup>

Typical values are at 25°C, AVDD = DVDD = 1.8 V, and –1-dBFS differential input, unless otherwise noted. Minimum and maximum values are across the full temperature range: T<sub>MIN</sub> = –40°C to T<sub>MAX</sub> = 85°C.

PARAMETER	DESCRIPTION	MIN	TYP	MAX	UNIT			
t <sub>SU</sub>	Data setup time	Data valid to zero-crossing of differential output clock (CLKOUTP – CLKOUTM) <sup>(2)</sup>			TBD	0.5	ns	
t <sub>HO</sub>	Data hold time	Zero-crossing of differential output clock (CLKOUTP – CLKOUTM) to data becoming invalid <sup>(2)</sup>			TBD	0.58	ns	
t <sub>PDI</sub>	Clock propagation delay	Input clock rising edge cross-over to output clock (CLKOUTP – CLKOUTM) rising edge cross-over			TBD	TBD	TBD	ns
	LVDS bit clock duty cycle	Duty cycle of differential clock (CLKOUTP – CLKOUTM)				49%		
t <sub>FALL</sub> , t <sub>RISE</sub>	Data fall time, Data rise time	Rise time measured from –100 mV to 100 mV 10 MSPS ≤ Sampling frequency ≤ 125 MSPS				0.11	ns	
t <sub>CLKRISE</sub> , t <sub>CLKFALL</sub>	Output clock rise time, Output clock fall time	Rise time measured from –100 mV to 100 mV 10 MSPS ≤ Sampling frequency ≤ 125 MSPS				0.11	ns	

- (1) Measurements are done with a transmission line of a 100-Ω characteristic impedance between the device and load. Setup and hold time specifications take into account the effect of jitter on the output data and clock.  
 (2) Data valid refers to a logic high of 100 mV and a logic low of –100 mV.

**Table 1. LVDS Timings at Lower Sampling Frequencies: 6x Serialization**

SAMPLING FREQUENCY (MSPS)	SETUP TIME (ns)			HOLD TIME (ns)			CLOCK PROPAGATION DELAY (ns)		
	t <sub>SU</sub>			t <sub>HO</sub>			t <sub>PDI</sub>		
	MIN	TYP	MAX	MIN	TYP	MAX	MIN	TYP	MAX
25	TBD	3.0		TBD	3.1		TBD	TBD	TBD
40	TBD	1.8		TBD	1.98		TBD	TBD	TBD
50	TBD	1.51		TBD	1.64		TBD	TBD	TBD
60	TBD	1.23		TBD	1.3		TBD	TBD	TBD
80	TBD	0.89		TBD	0.96		TBD	TBD	TBD
100	TBD	0.67		TBD	0.77		TBD	TBD	TBD

**Table 2. LVDS Timings at Lower Sampling Frequencies: 12x Serialization**

SAMPLING FREQUENCY (MSPS)	SETUP TIME (ns)			HOLD TIME (ns)			CLOCK PROPAGATION DELAY (ns)		
	t <sub>SU</sub>			t <sub>HO</sub>			t <sub>PDI</sub>		
	MIN	TYP	MAX	MIN	TYP	MAX	MIN	TYP	MAX
25	TBD	1.47		TBD	1.57		TBD	TBD	TBD
40	TBD	0.87		TBD	0.96		TBD	TBD	TBD
50	TBD	0.68		TBD	0.76		TBD	TBD	TBD
60	TBD	0.54		TBD	0.61		TBD	TBD	TBD
80	TBD	0.35		TBD	0.43		TBD	TBD	TBD

### 7.16 Typical Characteristics

Typical values are at  $T_A = 25^\circ\text{C}$ , ADC sampling rate = 125 MSPS, 50% clock duty cycle,  $AV_{DD} = DV_{DD} = 1.8\text{ V}$ ,  $-1\text{-dBFS}$  differential input,  $2\text{-}V_{PP}$  full-scale, 32k-point FFT, chopper disabled, and SNR reported with 1-MHz offset from DC when chopper disabled and from  $f_s/2$  when chopper enabled, unless otherwise noted.

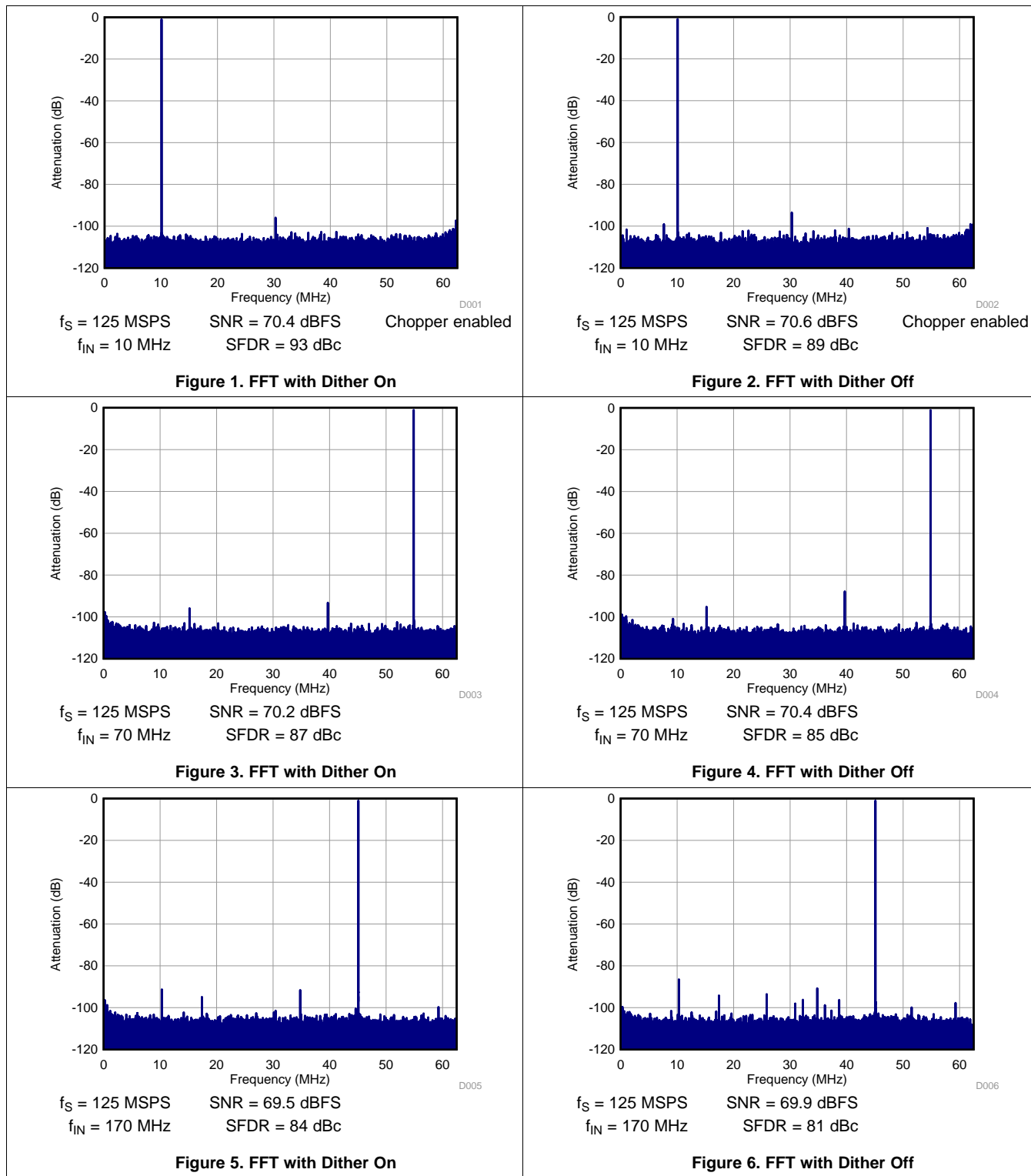

PRODUCT PREVIEW

### Typical Characteristics (continued)

Typical values are at  $T_A = 25^\circ\text{C}$ , ADC sampling rate = 125 MSPS, 50% clock duty cycle,  $AV_{DD} = DV_{DD} = 1.8\text{ V}$ ,  $-1\text{-dBFS}$  differential input,  $2\text{-}V_{PP}$  full-scale, 32k-point FFT, chopper disabled, and SNR reported with 1-MHz offset from DC when chopper disabled and from  $f_s/2$  when chopper enabled, unless otherwise noted.

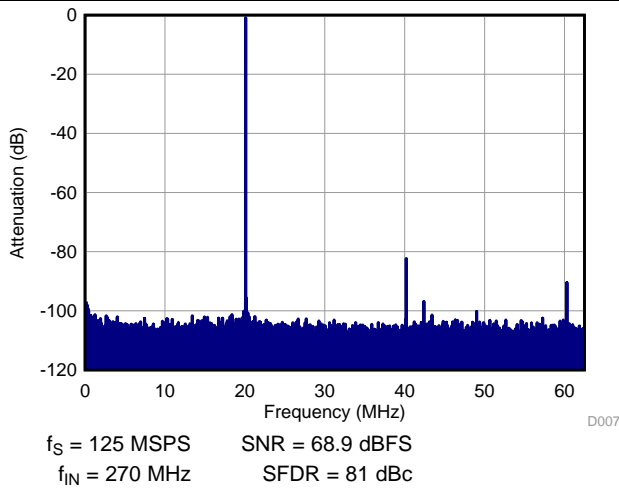

Figure 7. FFT with Dither On

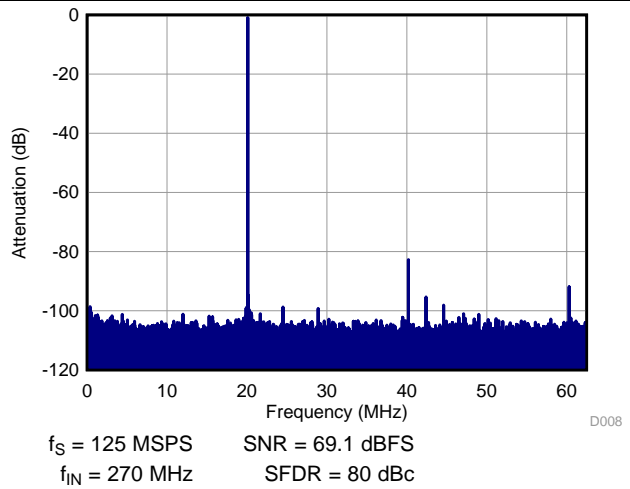

Figure 8. FFT with Dither Off

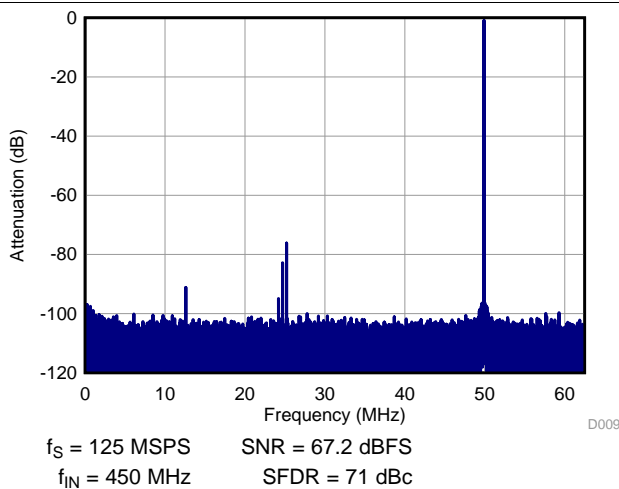

Figure 9. FFT with Dither On

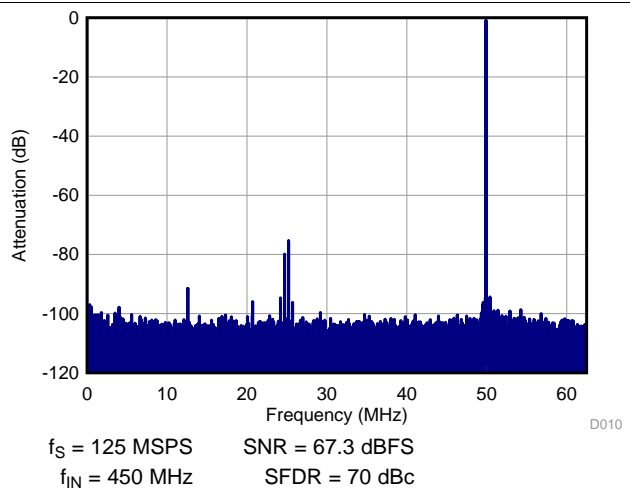

Figure 10. FFT with Dither Off

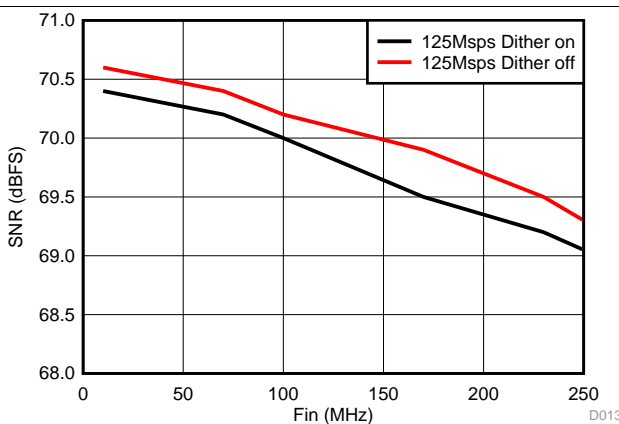

Figure 11. SNR vs Input Frequencies

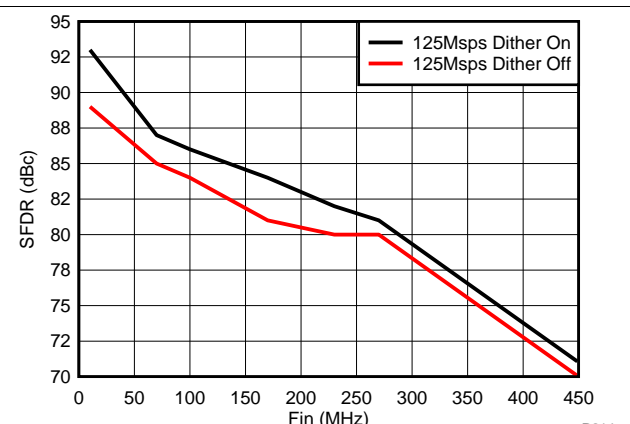

Figure 12. SFDR vs Input Frequencies

### Typical Characteristics (continued)

Typical values are at  $T_A = 25^\circ\text{C}$ , ADC sampling rate = 125 MSPS, 50% clock duty cycle,  $AVDD = DVDD = 1.8\text{ V}$ ,  $-1\text{-dBFS}$  differential input,  $2\text{-}V_{PP}$  full-scale, 32k-point FFT, chopper disabled, and SNR reported with 1-MHz offset from DC when chopper disabled and from  $f_s/2$  when chopper enabled, unless otherwise noted.

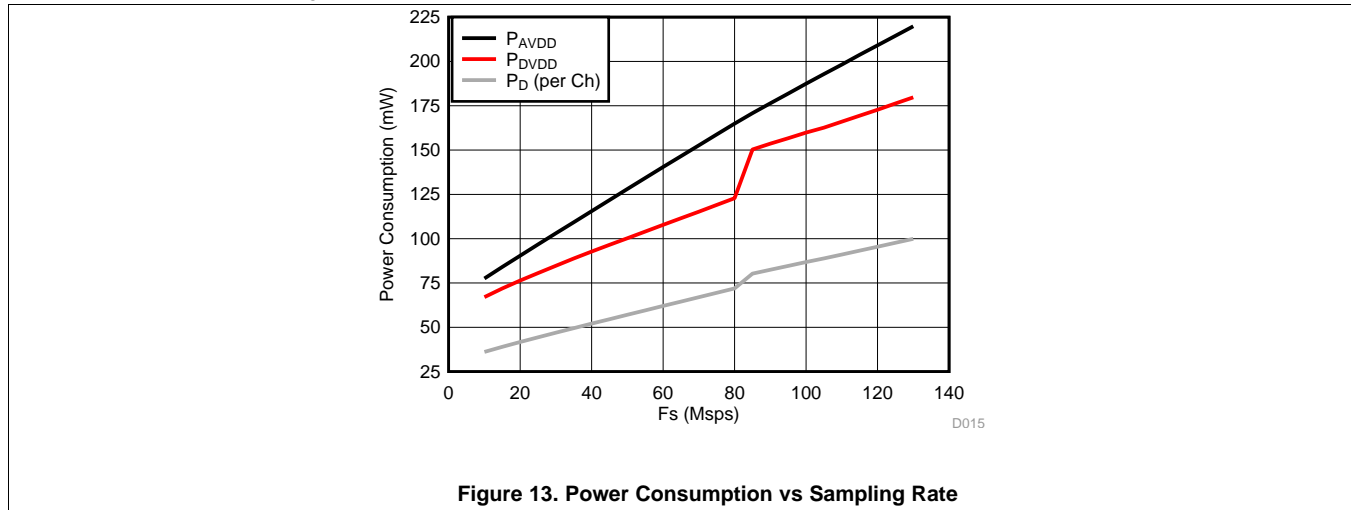
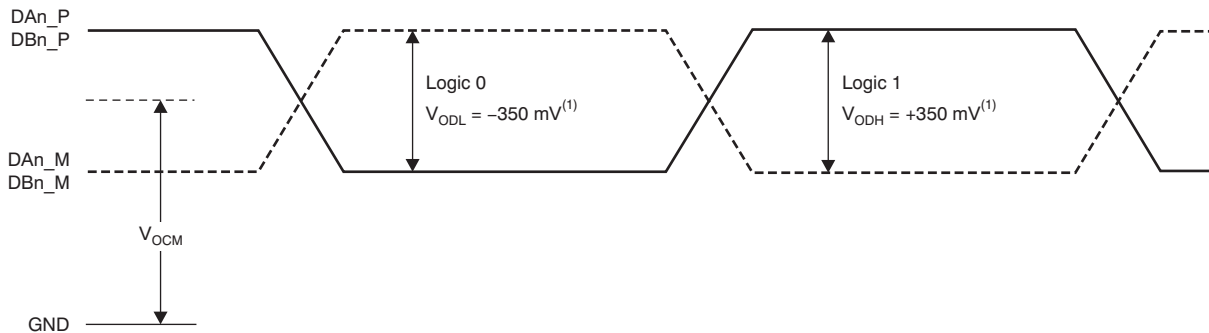

Figure 13. Power Consumption vs Sampling Rate

## 8 Parameter Measurement Information

### 8.1 Timing Diagrams



(1) With an external 100-Ω termination.

Figure 14. Serial LVDS Output Voltage Levels

Timing Diagrams (continued)

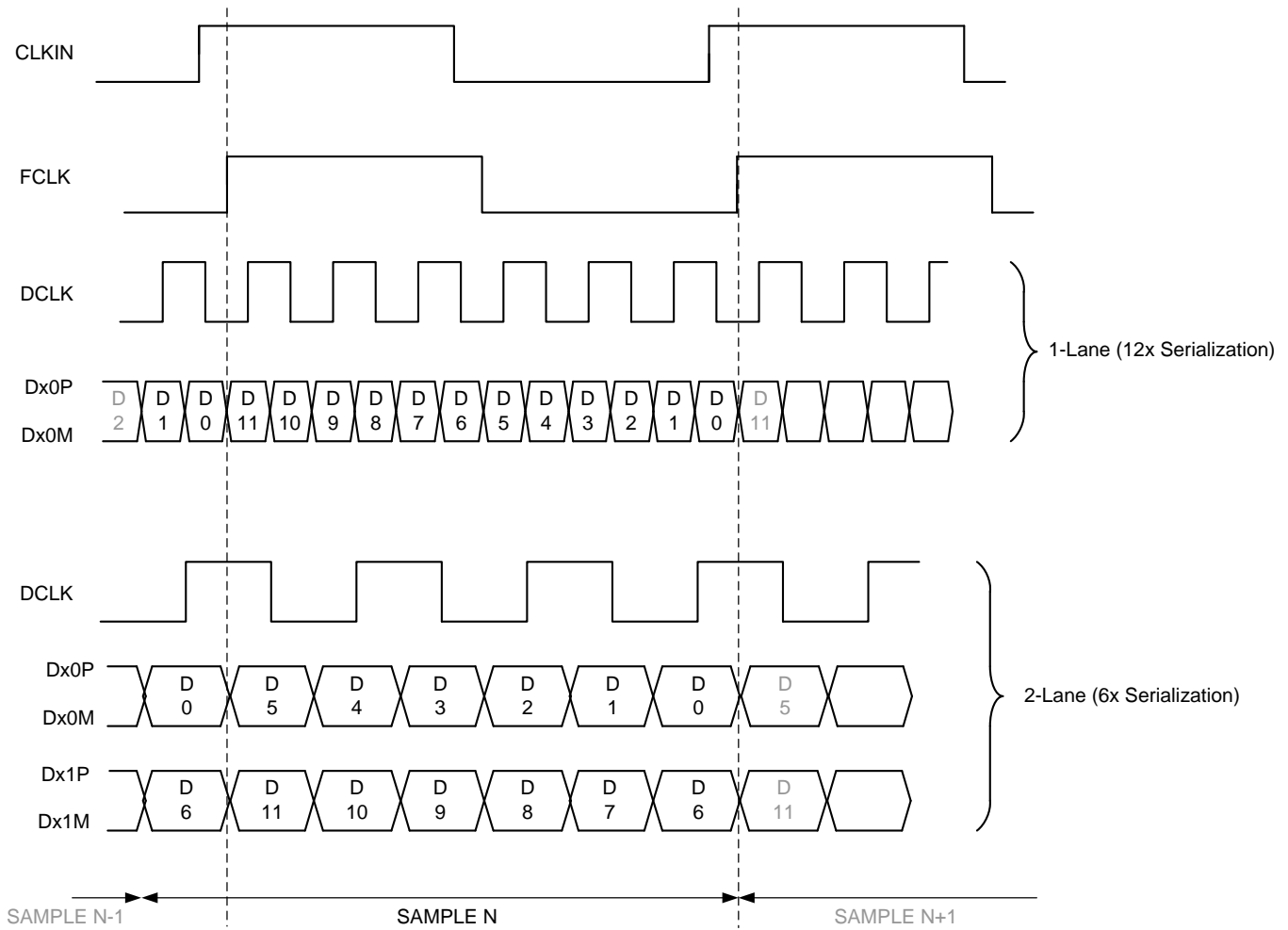

Figure 15. Output Timing Diagram

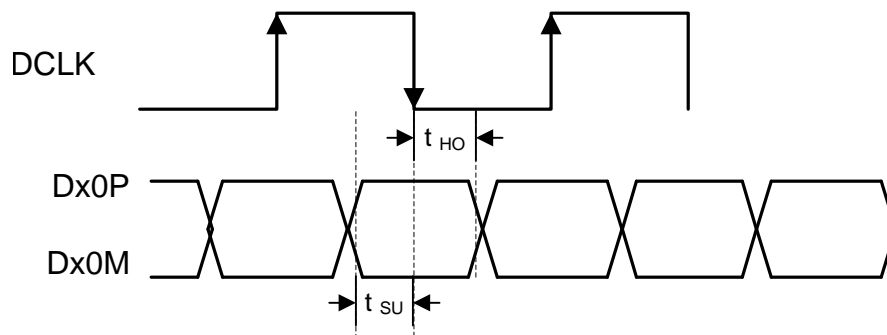

Figure 16. Setup and Hold Time

PRODUCT PREVIEW

## 9 Detailed Description

### 9.1 Overview

The ADC342x are a high-linearity, ultra-low power, quad-channel, 12-bit, 25-MSPS to 125-MSPS, analog-to-digital converter (ADC) family. The devices are designed specifically to support demanding, high input frequency signals with large dynamic range requirements. An input clock divider allows more flexibility for system clock architecture design while the SYSREF input enables complete system synchronization. The ADC342x family supports serial LVDS interface in order to reduce the number of interface lines, thus allowing for high system integration density. The serial LVDS interface is two-wire, where each ADC data are serialized and output over two LVDS pairs. An internal phase-locked loop (PLL) multiplies the incoming ADC sampling clock to derive the bit clock that is used to serialize the 12-bit output data from each channel. In addition to the serial data streams, the frame and bit clocks are also transmitted as LVDS outputs.

### 9.2 Functional Block Diagram

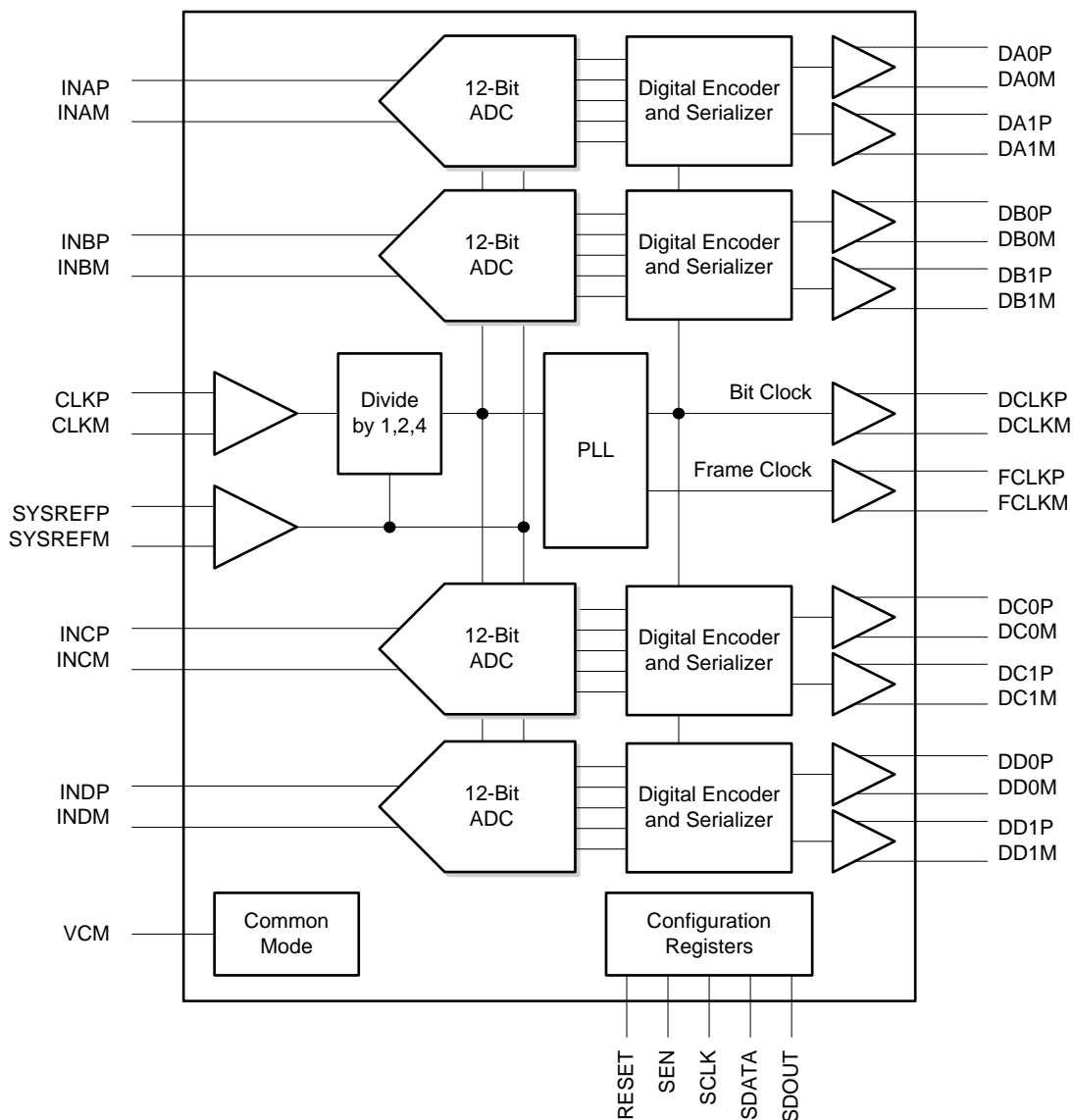

PRODUCT PREVIEW

### 9.3 Feature Description

#### 9.3.1 Analog Inputs

The ADC342x analog signal inputs are designed to be driven differentially. Each input pin (INP, INM) must swing symmetrically between  $(V_{CM} + 0.5\text{ V})$  and  $(V_{CM} - 0.5\text{ V})$ , resulting in a  $2\text{-}V_{PP}$  (default) differential input swing. The input sampling circuit has a 3-dB bandwidth that extends up to 540 MHz (50- $\Omega$  source driving 50- $\Omega$  termination between INP and INM).

#### 9.3.2 Clock Input

The device clock inputs can be driven differentially (sine, LVPECL, or LVDS) or single-ended (LVCMOS), with little or no difference in performance between them. The common-mode voltage of the clock inputs is set to 0.95 V using internal 5-k $\Omega$  resistors. The self-bias clock inputs of the ADC342x can be driven by the transformer-coupled, sine-wave clock source or by the ac-coupled, LVPECL and LVDS clock sources, as shown in Figure 17, Figure 18, and Figure 19. See Figure 20 for details regarding the internal clock buffer.

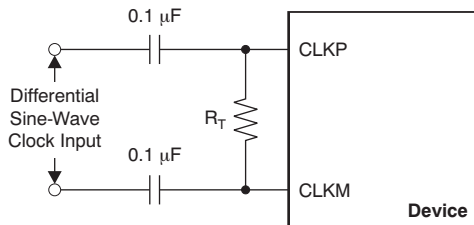

NOTE:  $R_T$  = termination resistor, if necessary.

Figure 17. Differential Sine-Wave Clock Driving Circuit

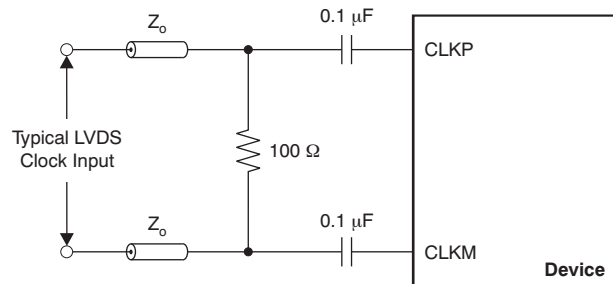

Figure 18. LVDS Clock Driving Circuit

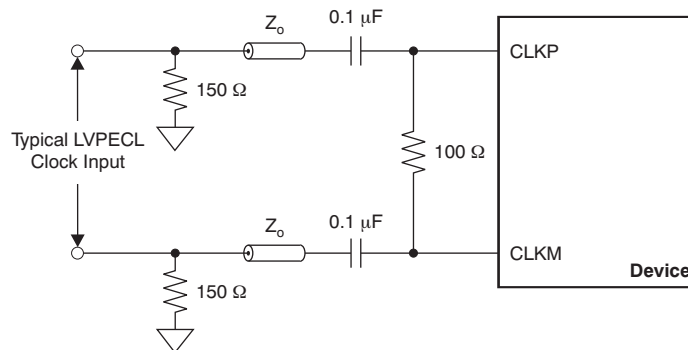
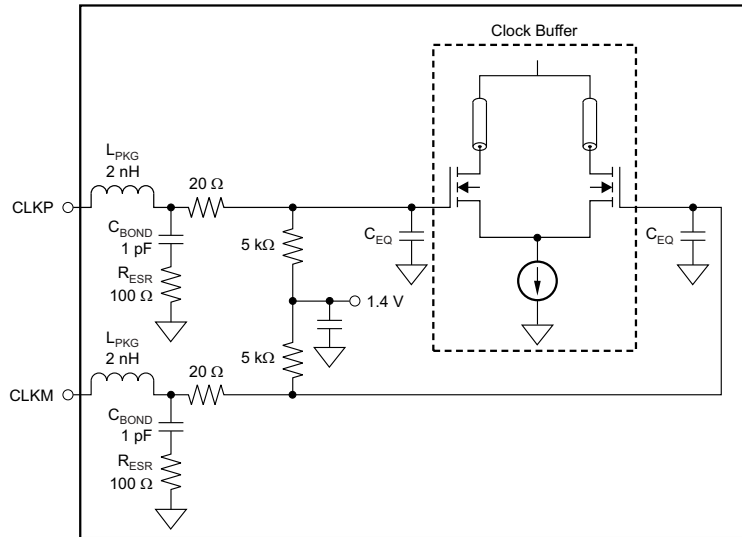

Figure 19. LVPECL Clock Driving Circuit



NOTE:  $C_{EQ}$  is 1 pF to 3 pF and is the equivalent input capacitance of the clock buffer.

**Figure 20. Internal Clock Buffer**

A single-ended CMOS clock can be ac-coupled to the CLKP input, with CLKM connected to ground with a 0.1- $\mu$ F capacitor, as shown in [Figure 21](#). However, for best performance the clock inputs must be driven differentially, thereby reducing susceptibility to common-mode noise. For high input frequency sampling, TI recommends using a clock source with very low jitter. Band-pass filtering of the clock source can help reduce the effects of jitter. There is no change in performance with a non-50% duty cycle clock input.

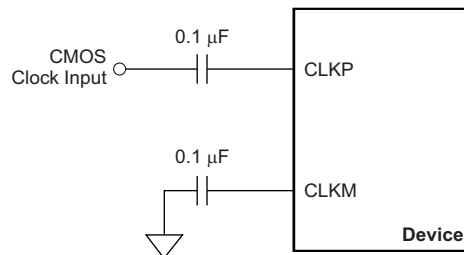

**Figure 21. Single-Ended Clock Driving Circuit**

### 9.3.2.1 SNR and Clock Jitter

The signal-to-noise ratio of the ADC is limited by three different factors, as shown in [Equation 1](#). Quantization noise (typically 74 dB for a 12-bit ADC) and thermal noise limit SNR at low input frequencies while the clock jitter sets SNR for higher input frequencies.

$$SNR_{ADC}[dBc] = -20 \cdot \log \sqrt{\left(10^{\frac{SNR_{Quantization\ Noise}}{20}}\right)^2 + \left(10^{\frac{SNR_{Thermal\ Noise}}{20}}\right)^2 + \left(10^{\frac{SNR_{Jitter}}{20}}\right)^2} \quad (1)$$

The SNR limitation resulting from sample clock jitter can be calculated with [Equation 2](#).

$$SNR_{Jitter}[dBc] = -20 \cdot \log(2\pi \cdot f_{in} \cdot T_{Jitter}) \quad (2)$$

The total clock jitter ( $T_{Jitter}$ ) has two components: the internal aperture jitter (130 fs for the device) which is set by the noise of the clock input buffer and the external clock.  $T_{Jitter}$  can be calculated with [Equation 3](#).

$$T_{Jitter} = \sqrt{(T_{Jitter,Ext.Clock\_Input})^2 + (T_{Aperture\_ADC})^2} \quad (3)$$

External clock jitter can be minimized by using high-quality clock sources and jitter cleaners as well as band-pass filters at the clock input while a faster clock slew rate improves the ADC aperture jitter. The devices have a typical thermal noise of 72.7 dBFS and internal aperture jitter of 130 fs. The SNR, depending on the amount of external jitter for different input frequencies, is shown in [Figure 22](#).

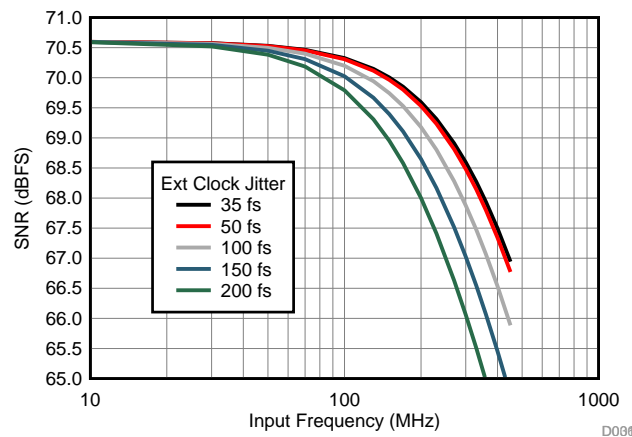

**Figure 22. SNR vs Frequency for Different Clock Jitter**

### 9.3.3 Digital Output Interface

The devices offer two different output format options, thus making interfacing to a field-programmable gate array (FPGA) or an application-specific integrated circuit (ASIC) easy. Each option can be easily programmed using the serial interface, as shown in [Table 3](#). The output interface options are:

- One-wire, 1x frame clock, 12x serialization with the DDR bit clock and
- Two-wire, 1x frame clock, 6x serialization with the DDR bit clock.

**Table 3. Interface Rates**

INTERFACE OPTIONS	SERIALIZATION	MAXIMUM RECOMMENDED SAMPLING FREQUENCY (MSPS)	BIT CLOCK FREQUENCY (MHz)	FRAME CLOCK FREQUENCY (MHz)	SERIAL DATA RATE PER WIRE (Mbps)
One-wire	12x	80	480	80	960
Two-wire	6x	125	375	125	750

#### 9.3.3.1 One-Wire Interface: 12x Serialization

In this interface option, the device outputs the data of each ADC serially on a single LVDS pair (one-wire). The data are available at the rising and falling edges of the bit clock (DDR bit clock). The ADC outputs a new word at the rising edge of every frame clock, starting with the MSB. The data rate is 12x sample frequency (12x serialization).

### 9.3.3.2 Two-Wire Interface: 6x Serialization

The two-wire interface is recommended for sampling frequencies above 65 MSPS. The output data rate is 6x sample frequency because six data bits are output every clock cycle on each differential pair. Each ADC sample is sent over the two wires with the six MSBs on Dx1P, Dx1M and the six LSBs on Dx0P, Dx0M, as shown in Figure 23.

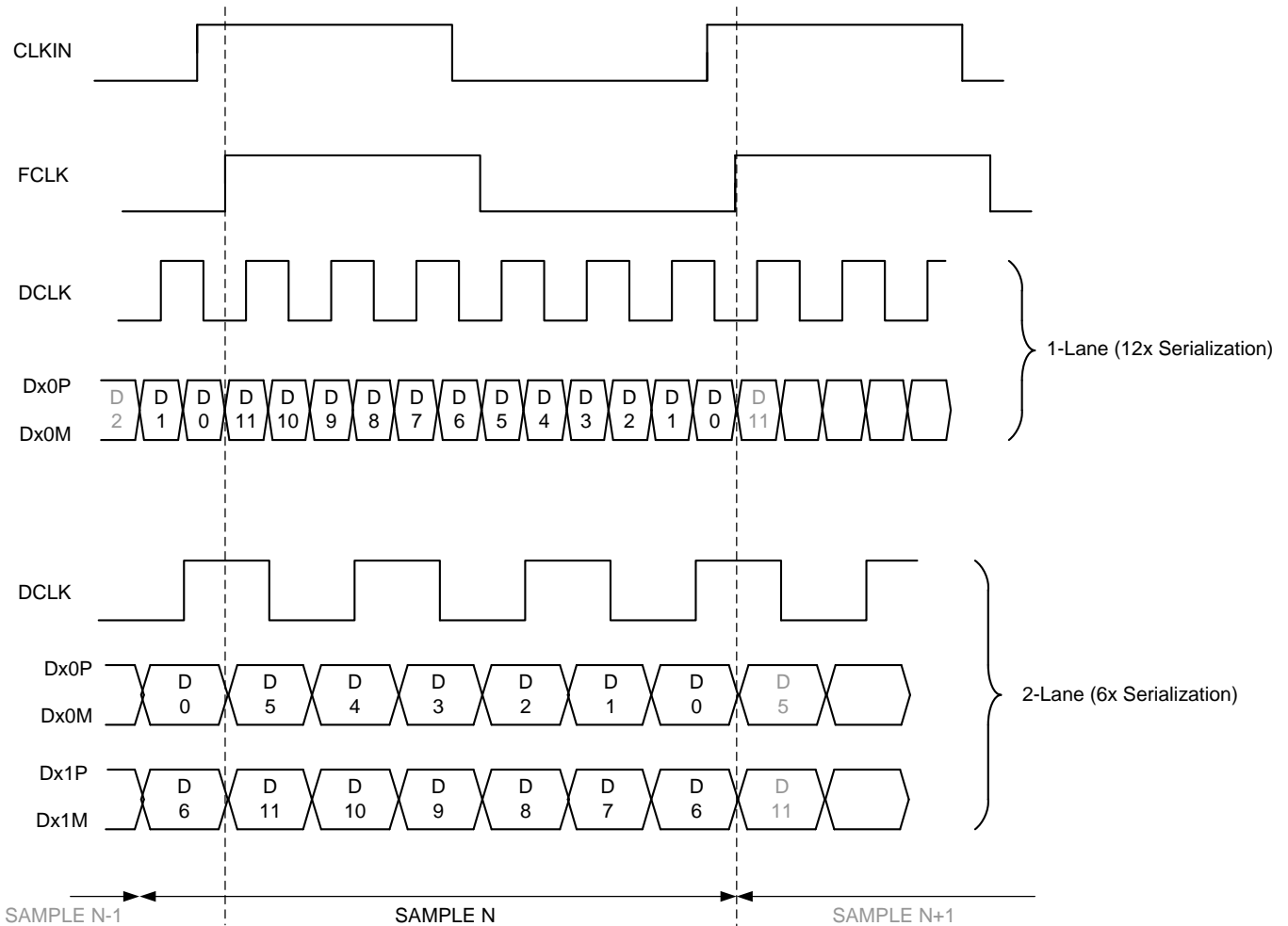

Figure 23. Output Timing Diagram

## 9.4 Device Functional Modes

### 9.4.1 Input Clock Divider

The devices are equipped with an internal divider on the clock input. The clock divider allows operation with a faster input clock, thus simplifying the system clock distribution design. The clock divider can be bypassed for operation with a 125-MHz clock while the divide-by-2 option supports a maximum input clock of 250 MHz and the divide-by-4 option provides a maximum input clock frequency of 500 MHz.

## Device Functional Modes (continued)

### 9.4.2 Chopper Functionality

The devices are equipped with an internal chopper front-end. Enabling the chopper function swaps the ADC noise spectrum by shifting the  $1/f$  noise from dc to  $f_S / 2$ . Figure 24 shows the noise spectrum with the chopper off and Figure 25 shows the noise spectrum with the chopper on. This function is especially useful in applications requiring good ac performance at low input frequencies or in dc-coupled applications. The chopper can be enabled via SPI register writes and is recommended for input frequencies below 30 MHz. The chopper function creates a spur at  $f_S / 2$  that must be filtered out digitally.

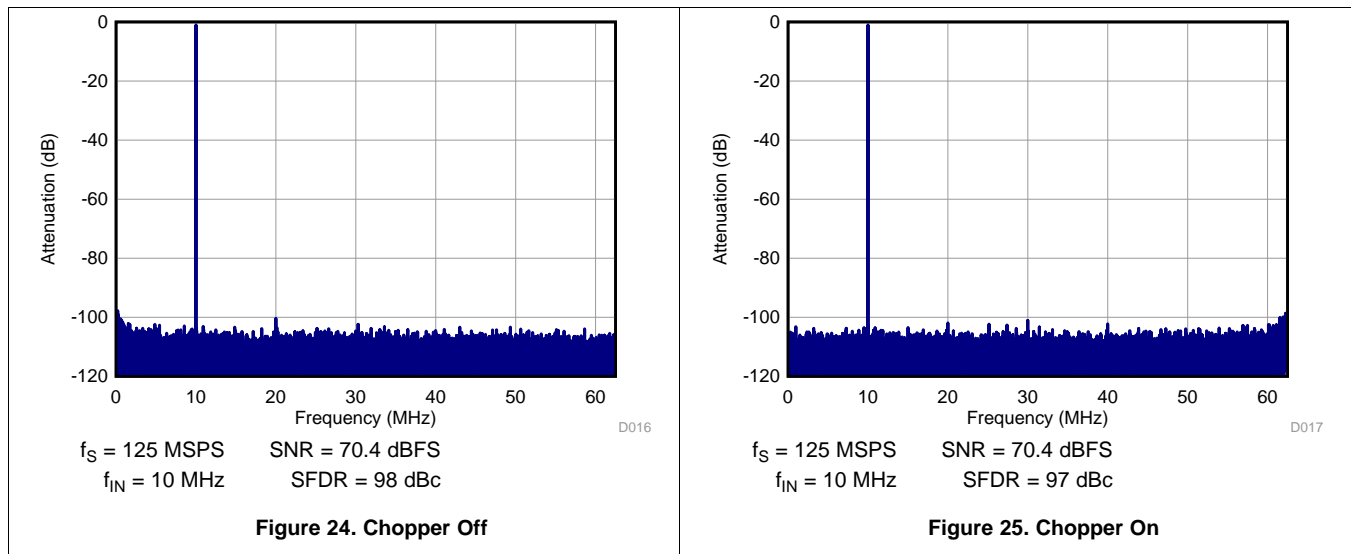

### 9.4.3 Power-Down Control

The power-down functions of the ADC342x can be controlled either through the parallel control pin (PDN) or through an SPI register setting (see Figure 43, register 15h). The PDN pin can also be configured via SPI to a global power-down or standby functionality, as shown in Table 4.

**Table 4. Power-Down Modes**

FUNCTION	POWER CONSUMPTION (mW)	WAKE-UP TIME ( $\mu$ s)
Global power-down	5	85
Standby	45	35

### 9.4.4 Internal Dither Algorithm

The ADC342x use an internal dither algorithm to achieve high SFDR and a clean spectrum. However, the dither algorithm marginally degrades SNR, creating a trade-off between SNR and SFDR. If desired, the dither algorithm can be turned off by using the DIS DITH CHx registers bits. Figure 26 and Figure 27 show the effect of using dither algorithms.

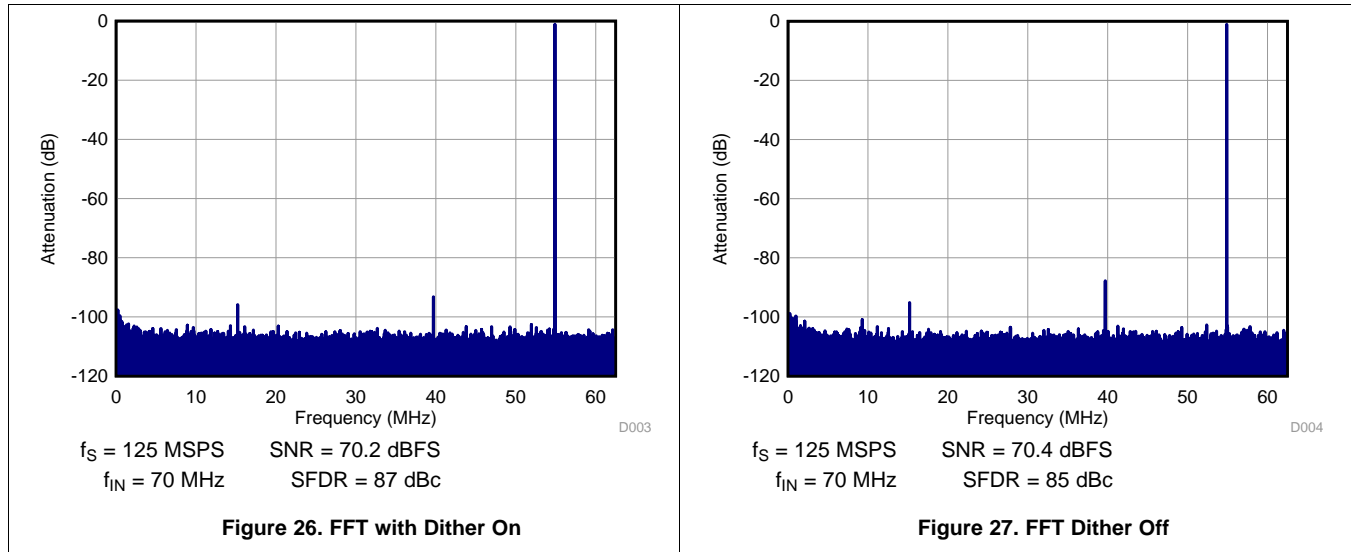

## 9.5 Programming

The ADC342x can be configured using a serial programming interface, as described in this section.

### 9.5.1 Serial Interface

The device has a set of internal registers that can be accessed by the serial interface formed by the SEN (serial interface enable), SCLK (serial interface clock), SDATA (serial interface data), and SDOOUT (serial interface data output) pins. Serially shifting bits into the device is enabled when SEN is low. Serial data SDATA are latched at every SCLK rising edge when SEN is active (low). The serial data are loaded into the register at every 24th SCLK rising edge when SEN is low. When the word length exceeds a multiple of 24 bits, the excess bits are ignored. Data can be loaded in multiples of 24-bit words within a single active SEN pulse. The interface can function with SCLK frequencies from 20 MHz down to very low speeds (of a few hertz) and also with a non-50% SCLK duty cycle.

## Programming (continued)

### 9.5.1.1 Register Initialization

After power-up, the internal registers must be initialized to their default values through a hardware reset by applying a high pulse on the RESET pin (of durations greater than 10 ns), as shown in Figure 28. If required, the serial interface registers can be cleared during operation either:

1. Through a hardware reset, or
2. By applying a software reset. When using the serial interface, set the RESET bit (D0 in register address 06h) high. This setting initializes the internal registers to the default values and then self-resets the RESET bit low. In this case, the RESET pin is kept low.

#### 9.5.1.1.1 Serial Register Write

The device internal register can be programmed with these steps:

1. Drive the SEN pin low,
2. Set the R/W bit to 0 (bit A15 of the 16-bit address),
3. Set bit A14 in the address field to 1,
4. Initiate a serial interface cycle by specifying the address of the register (A13 to A0) whose content must be written, and
5. Write the 8-bit data that are latched in on the SCLK rising edge.

Figure 28 and Table 5 show the timing requirements for the serial register write operation.

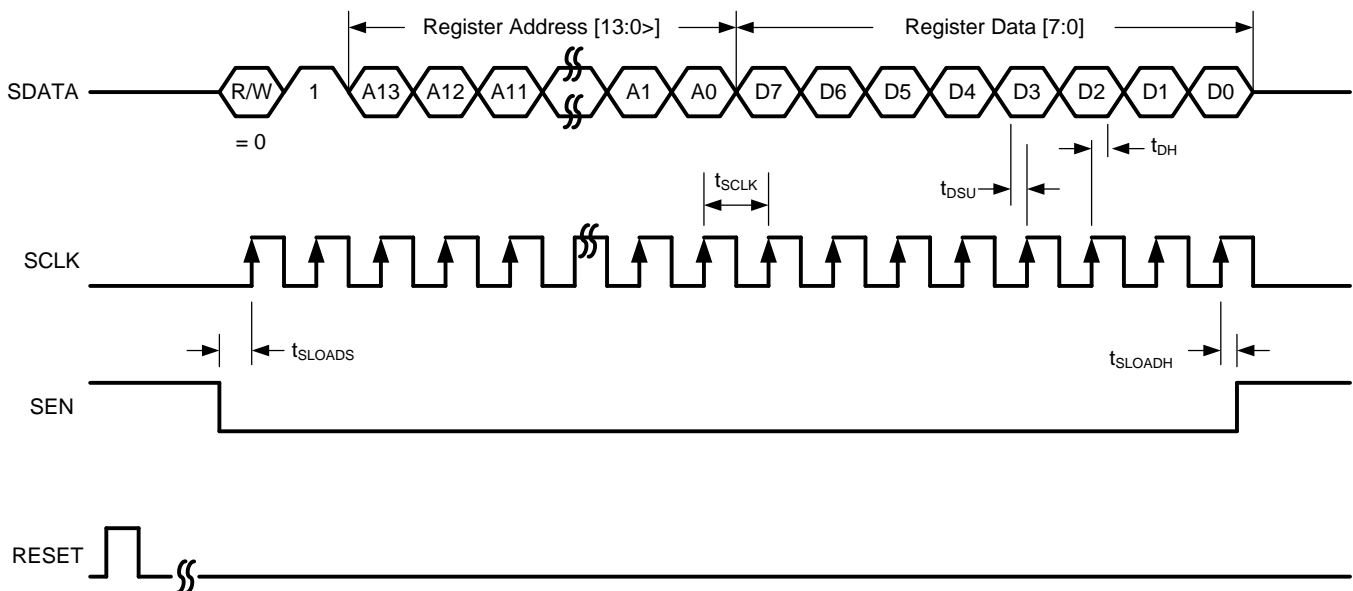

Figure 28. Serial Register Write Timing Diagram

Table 5. Serial Interface Timing<sup>(1)</sup>

PARAMETER	MIN	TYP	MAX	UNIT
f <sub>SCLK</sub>	SCLK frequency (equal to 1 / t <sub>SCLK</sub> )	> dc	20	MHz
t <sub>SLOADS</sub>	SEN to SCLK setup time	25		ns
t <sub>SLOADH</sub>	SCLK to SEN hold time	25		ns
t <sub>DSU</sub>	SDIO setup time	25		ns
t <sub>DH</sub>	SDIO hold time	25		ns

(1) Typical values are at 25°C, full temperature range is from T<sub>MIN</sub> = -40°C to T<sub>MAX</sub> = 85°C, and AVDD = DVDD = 1.8 V, unless otherwise noted.

### 9.5.1.1.2 Serial Register Readout

The device includes a mode where the contents of the internal registers can be read back using the SDOUT pin. This readback mode may be useful as a diagnostic check to verify the serial interface communication between the external controller and the ADC. The procedure to read the contents of the serial registers is as follows:

1. Drive the SEN pin low.
2. Set the R/W bit (A15) to 1. This setting disables any further writes to the registers.
3. Set bit A14 in the address field to 1.
4. Initiate a serial interface cycle specifying the address of the register (A13 to A0) whose content must be read.
5. The device outputs the contents (D7 to D0) of the selected register on the SDOUT pin.
6. The external controller can latch the contents at the SCLK rising edge.
7. To enable register writes, reset the R/W register bit to 0.

When READOUT is disabled, the SDOUT pin is in a high-impedance mode. If serial readout is not used, the SDOUT pin must float. Figure 29 shows a timing diagram of the serial register read operation. Data appear on the SDOUT pin at the SCLK falling edge with an approximate delay ( $t_{SD\_DELAY}$ ) of 20 ns, as shown in Figure 30.

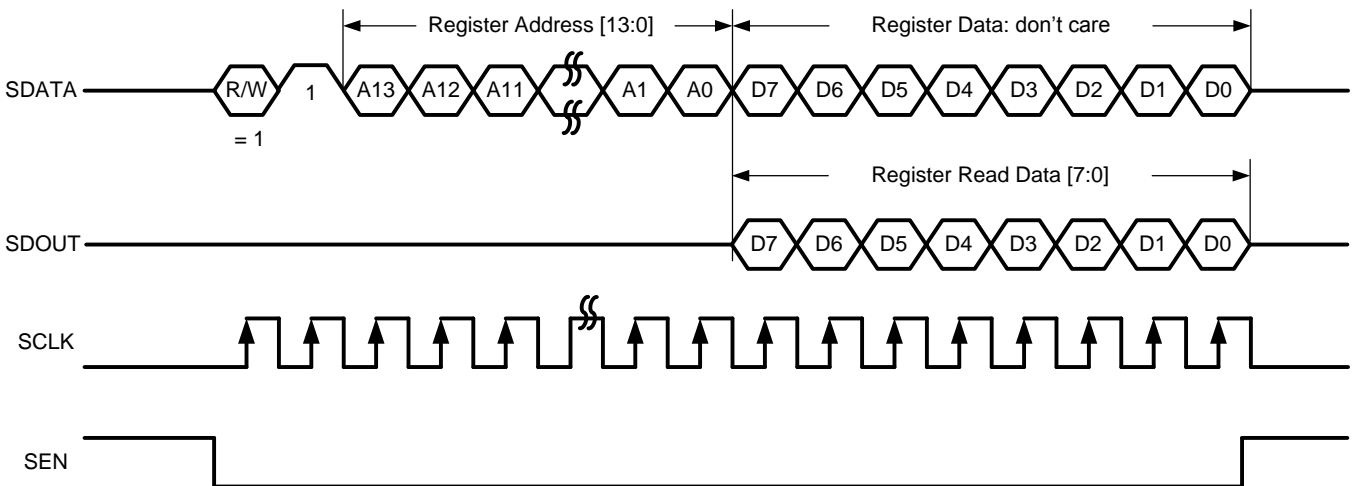

Figure 29. Serial Register Read Timing Diagram

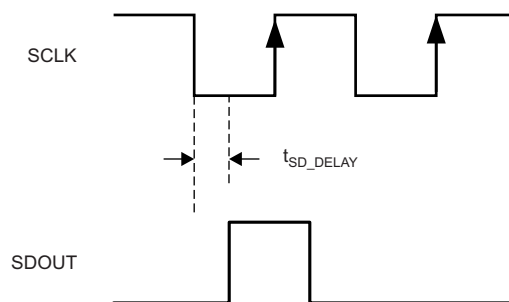
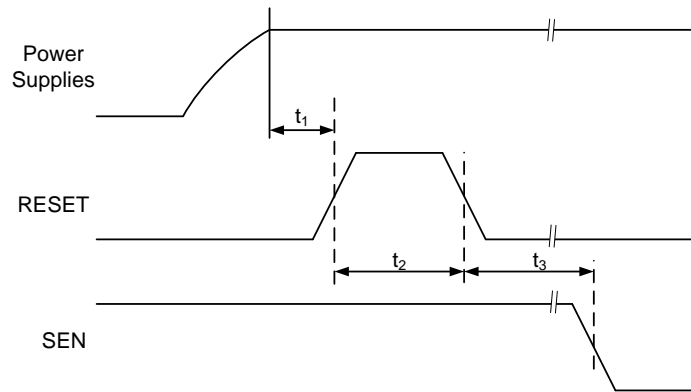

Figure 30. SDOUT Timing Diagram

### 9.5.2 Register Initialization

After power-up, the internal registers must be initialized to their default values through a hardware reset by applying a high pulse on the RESET pin, as shown in [Figure 31](#) and [Table 6](#).



**Figure 31. Initialization of Serial Registers after Power-Up**

**Table 6. Power-Up Timing**

PARAMETER	CONDITIONS	MIN	TYP	MAX	UNIT
$t_1$	Power-on delay	Delay from power up to active high RESET pulse	1		ms
$t_2$	Reset pulse duration	Active high RESET pulse duration	10		ns
$t_3$	Register write delay	Delay from RESET disable to SEN active	100		ns

If required, the serial interface registers can be cleared during operation either:

1. Through hardware reset, or
2. By applying a software reset. When using the serial interface, set the RESET bit (D0 in register address 06h) high. This setting initializes the internal registers to the default values and then self-resets the RESET bit low. In this case, the RESET pin is kept low.

## 9.6 Register Maps

**Table 7. Register Map Summary**

REGISTER ADDRESS	REGISTER DATA							
	7	6	5	4	3	2	1	0
01	DIS DITH CHA		DIS DITH CHB		DIS DITH CHC		DIS DITH CHD	
03	0	0	0	0	0	0	0	ODD EVEN
04	0	0	0	0	0	0	0	FLIP BITS
05	0	0	0	0	0	0	0	1W-2W
06	0	0	0	0	0	0	TEST PATTERN EN	RESET
07	0	0	0	0	0	0	0	OVR ON LSB
09	0	0	0	0	0	0	ALIGN TEST PATTERN	DATA FORMAT
0A	0	0	0	0	CHA TEST PATTERN			
0B	CHB TEST PATTERN			0	0	0	0	0
0E	CUSTOM PATTERN[11:4]							
0F	CUSTOM PATTERN[3:0]				0	0	0	0
15	0	CHA PDN	CHB PDN	0	STANDBY	GLOBAL PDN	0	CONFIG PDN PIN
25	LVDS SWING							
27	CLK DIV		0	0	0	0	0	0
122	0	0	0	0	0	0	DIS CHOP CHA	0
134	0	0	DIS DITH CHA	0	DIS DITH CHA	0	0	0
139	0	0	0	0	SP1 CHA	0	0	0
222	0	0	0	0	0	0	DIS CHOP CHD	0
234	0	0	DIS DITH CHD	0	DIS DITH CHD	0	0	0
239	0	0	0	0	SP1 CHD	0	0	0
422	0	0	0	0	0	0	DIS CHOP CHB	0
434	0	0	DIS DITH CHB	0	DIS DITH CHB	0	0	0
439	0	0	0	0	SP1 CHB	0	0	0
522	0	0	0	0	0	0	DIS CHOP CHC	0
534	0	0	DIS DITH CHC	0	DIS DITH CHC	0	0	0
539	0	0	0	0	SP1 CHC	0	0	0

PRODUCT PREVIEW

**9.6.1 Serial Register Description**
**Figure 32. Register 01h**

7	6	5	4	3	2	1	0
DIS DITH CHA		DIS DITH CHB		DIS DITH CHC		DIS DITH CHD	

**Table 8. Register 01h Description**

Name	Description
<b>Bits 7:6</b>	<b>DIS DITH CHA</b>
	These bits enable or disable the on-chip dither. Control this bit with bits 5 and 3 of register 134h. 00 = Default 11 = Dither is disabled for channel A. In this mode, SNR typically improves by 0.2 dB at 70 MHz.
<b>Bits 5:4</b>	<b>DIS DITH CHB</b>
	These bits enable or disable the on-chip dither. Control this bit with bits 5 and 3 of register 434h. 00 = Default 11 = Dither is disabled for channel B. In this mode, SNR typically improves by 0.2 dB at 70 MHz.
<b>Bits 3:2</b>	<b>DIS DITH CHC</b>
	These bits enable or disable the on-chip dither. Control this bit with bits 5 and 3 of register 534h. 00 = Default 11 = Dither is disabled for channel B. In this mode, SNR typically improves by 0.2 dB at 70 MHz.
<b>Bits 1:0</b>	<b>DIS DITH CHD</b>
	These bits enable or disable the on-chip dither. Control this bit with bits 5 and 3 of register 234h. 00 = Default 11 = Dither is disabled for channel B. In this mode, SNR typically improves by 0.2 dB at 70 MHz.

**Figure 33. Register 03h**

7	6	5	4	3	2	1	0
0	0	0	0	0	0	0	ODD EVEN

**Table 9. Register 03h Description**

Name	Description
<b>Bits 7:6</b>	<b>Must write 0</b>
<b>Bit 0</b>	<b>ODD EVEN:</b> Select bit sequence on output lanes. (In 2-wire mode only)
	0 = Bits D0, D1, and D2 appear on lane 0; bits D7, D8, D9 appear on lane 1. 1 = Bits D0, D2, and D4 appear on lane 0; bits D1, D3, and D5 appear on lane 1.

**Figure 34. Register 04h**

7	6	5	4	3	2	1	0
0	0	0	0	0	0	0	FLIP BITS

**Table 10. Register 04h Description**

Name	Description
<b>Bits 7:6</b>	<b>Must write 0</b>
<b>Bit 0</b>	<b>FLIP BITS:</b> Flip bits on the output lanes
	0 = LSB comes out first, sequence is D0, D1, D2, and so forth 1 = MSB comes out first, sequence is D13, D12, D11, and so forth

**Figure 35. Register 05h**

7	6	5	4	3	2	1	0
0	0	0	0	0	0	0	1W-2W

**Table 11. Register 05h Description**

Name	Description
<b>Bits 7:6</b>	<b>Must write 0</b>
<b>Bit 0</b>	<b>1W-2W:</b>
	This bit transmits output data on either one or two wires. 0 = Output data are transmitted on two wires (Dx0P, Dx0M and Dx1P, Dx1M) 1 = Output data are transmitted on one wire (Dx0P, Dx0M). In this mode, the recommended $f_s$ is less than 62.5 MSPS.

**Figure 36. Register 06h**

7	6	5	4	3	2	1	0
0	0	0	0	0	0	TEST PATTERN EN	RESET

**Table 12. Register 06h Description**

Name	Description
<b>Bits 7:2</b>	<b>Must write 0</b>
<b>Bit 1</b>	<b>TEST PATTERN EN: Enables test pattern selection for the digital outputs</b>
	0 = Normal output 1 = Test pattern output enabled
<b>Bit 0</b>	<b>RESET: Software reset applied</b>
	This bit resets all internal registers to the default values and self-clears to 0.

**Figure 37. Register 07h**

7	6	5	4	3	2	1	0
0	0	0	0	0	0	0	OVR ON LSB

**Table 13. Register 07h Description**

Name	Description
<b>Bits 7:6</b>	<b>Must write 0</b>
<b>Bit 0</b>	<b>OVR ON LSB: OVR information on the LSB bits</b>
	0 = Output data bit 0 functions as the LSB of the 12-bit data 1 = Output data bit 0 carries the overrange (OVR) information.

**Figure 38. Register 09h**

7	6	5	4	3	2	1	0
0	0	0	0	0	0	ALIGN TEST PATTER	DATA FORMAT

**Table 14. Register 09h Description**

Name	Description
<b>Bits 7:2</b>	<b>Must write 0</b>
<b>Bit 1</b>	<b>ALIGN TEST PATTERN</b>
	This bit aligns the test patterns across the outputs of both channels. 0 = Test patterns of both channels are free running 1 = Test patterns of both channels are aligned
<b>Bit 0</b>	<b>DATA FORMAT: Digital output data format</b>
	0 = Twos complement 1 = offset binary

**Figure 39. Register 0Ah**

7	6	5	4	3	2	1	0
CHA TEST PATTERN				CHB TEST PATTERN			

**Table 15. Register 0Ah Description**

Name	Description
<b>Bits 7:4</b>	<b>CHA TEST PATTERN</b>
	<p>These bits control test pattern for channel A after the TEST PATTERN EN bit is set.</p> <p>0000 = Normal operation            0001 = All 0's            0010 = All 1's            0011 = Toggle pattern: data alternate between 101010101010 and 010101010101.            0100 = Digital ramp: data increment by 1 LSB every clock cycle from code 0 to 4095.            0110 = Custom pattern: output data are the same as programmed by the CUSTOM PATTERN register bits.            1000 = Deskew pattern: data are AAAh.            1010 = PRBS pattern: data are a sequence of pseudo random numbers.            1011 = 8-point sine wave: data are a repetitive sequence of the following eight numbers that form a sine-wave: 0, 599, 2048, 3496, 4095, 3496, 2048, 599.            Others = Do not use</p>
<b>Bits 3:0</b>	<b>CHB TEST PATTERN</b>
	<p>These bits control test pattern for channel B after the TEST PATTERN EN bit is set.</p> <p>0000 = Normal operation            0001 = All 0's            0010 = All 1's            0011 = Toggle pattern: data alternate between 101010101010 and 010101010101.            0100 = Digital ramp: data increment by 1 LSB every clock cycle from code 0 to 4095.            0110 = Custom pattern: output data are the same as programmed by the CUSTOM PATTERN register bits.            1000 = Deskew pattern: data are AAAh.            1010 = PRBS pattern: data are a sequence of pseudo random numbers.            1011 = 8-point sine wave: data are a repetitive sequence of the following eight numbers that form a sine-wave: 0, 599, 2048, 3496, 4095, 3496, 2048, 599.            Others = Do not use</p>

**Figure 40. Register 0Bh**

7	6	5	4	3	2	1	0
CHC TEST PATTERN				CHD TEST PATTERN			

**Table 16. Register 0Bh Description**

Name	Description
<b>Bits 7: 4</b>	<b>CHC TEST PATTERN</b>
	<p>These bits control test pattern for channel C after the TEST PATTERN EN bit is set.</p> <p>0000 = Normal operation            0001 = All 0's            0010 = All 1's            0011 = Toggle pattern: data alternate between 101010101010 and 010101010101.            0100 = Digital ramp: data increment by 1 LSB every clock cycle from code 0 to 4095.            0110 = Custom pattern: output data are the same as programmed by the CUSTOM PATTERN register bits.            1000 = Deskew pattern: data are AAAh.            1010 = PRBS pattern: data are a sequence of pseudo random numbers.            1011 = 8-point sine wave: data are a repetitive sequence of the following eight numbers that form a sine-wave: 0, 599, 2048, 3496, 4095, 3496, 2048, 599.            Others = Do not use</p>
<b>Bits 3:0</b>	<b>CHD TEST PATTERN</b>
	<p>These bits control test pattern for channel D after the TEST PATTERN EN bit is set.</p> <p>0000 = Normal operation            0001 = All 0's            0010 = All 1's            0011 = Toggle pattern: data alternate between 101010101010 and 010101010101.            0100 = Digital ramp: data increment by 1 LSB every clock cycle from code 0 to 4095.            0110 = Custom pattern: output data are the same as programmed by the CUSTOM PATTERN register bits.            1000 = Deskew pattern: data are AAAh.            1010 = PRBS pattern: data are a sequence of pseudo random numbers.            1011 = 8-point sine wave: data are a repetitive sequence of the following eight numbers that form a sine-wave: 0, 599, 2048, 3496, 4095, 3496, 2048, 599.            Others = Do not use</p>

**Figure 41. Register 0Eh**

7	6	5	4	3	2	1	0
CUSTOM PATTERN[11:4]							

**Table 17. Register 0Eh Description**

Name	Description
<b>Bits 7:0</b>	<b>CUSTOM PATTERN[11:4]</b>
	These bits set the 12-bit custom pattern (bits 11:4) for all channels.

**Figure 42. Register 0Fh**

7	6	5	4	3	2	1	0
CUSTOM PATTERN[3:0]				0	0	0	0

**Table 18. Register 0Fh Description**

Name	Description
<b>Bits 7:4</b>	<b>CUSTOM PATTERN[3:0]</b>
	These bits set the 12-bit custom pattern (bits 3:0) for all channels.
<b>Bits 3:0</b>	<b>Must write 0</b>

**Figure 43. Register 15h**

7	6	5	4	3	2	1	0
0	CHA PDN	CHB PDN	0	STANDBY	GLOBAL PDN	0	CONFIG PDN PIN

**Table 19. Register 15h Description**

Name	Description
<b>Bit 7</b>	<b>Must write 0</b>
<b>Bit 6</b>	<b>CHA PDN</b> 0 = Normal operation 1 = Power-down channel A
<b>Bit 5</b>	<b>CHB PDN</b> 0 = Normal operation 1 = Power-down channel B
<b>Bit 4</b>	<b>Must write 0</b>
<b>Bit 3</b>	<b>STANDBY: ADCs of both channels enter standby</b> 0 = Normal operation 1 = Standby
<b>Bit 2</b>	<b>GLOBAL PDN</b> 0 = Normal operation 1 = Global power-down
<b>Bit 1</b>	<b>Must write 0</b>
<b>Bit 0</b>	<b>CONFIG PDN PIN:</b> This bit configures the PDN pin as either a global power-down or standby pin. 0 = Logic high voltage on PDN pin sends the device into global power-down 1 = Logic high voltage on PDN pin sends the device into standby

**Figure 44. Register 25h**

7	6	5	4	3	2	1	0
LVDS SWING							

**Table 20. Register 25h Description**

Name	Description
<b>Bits 7:0</b>	<b>LVDS SWING</b>
	These bits control the swing of the LVDS outputs (including the data output, bit clock, and frame clock).

**Figure 45. Register 27h**

7	6	5	4	3	2	1	0
CLK DIV		0	0	0	0	0	0

**Table 21. Register 27h Description**

Name	Description
<b>Bits 7:6</b>	<b>CLK DIV: Internal clock divider for the input sampling clock</b>
	00 = Divide-by-1 01 = Divide-by-1 10 = Divide-by-2 11 = Divide-by-4
<b>Bits 5:0</b>	<b>Must write 0</b>

**Figure 46. Register 122h**

7	6	5	4	3	2	1	0
0	0	0	0	0	0	DIS CHOP CHA	0

**Table 22. Register 122h Description**

Name	Description
<b>Bits 7:2</b>	<b>Must write 0</b>
<b>Bit 1</b>	<b>DIS CHOP CHA: Disable chopper</b>
	Set this bit to shift 1/f noise floor at dc. 0 = 1/f noise floor is centered at $f_S / 2$ (default) 1 = Chopper mechanism is disabled; 1/f noise floor is centered at dc
<b>Bit 0</b>	<b>Must write 0</b>

**Figure 47. Register 134h**

7	6	5	4	3	2	1	0
0	0	DIS DITH CHA	0	DIS DITH CHA	0	0	0

**Table 23. Register 134h Description**

Name	Description
<b>Bits 7:6</b>	<b>Must write 0</b>
<b>Bit 5</b>	<b>DIS DITH CHA</b>
	Set this bit with bits 7 and 6 of register 01h. 00 = Default 11 = Dither is disabled for channel A. In this mode, SNR typically improves by 0.2 dB at 70 MHz.
<b>Bit 4</b>	<b>Must write 0</b>
<b>Bit 3</b>	<b>DIS DITH CHA</b>
	Set this bit with bits 7 and 6 of register 01h. 00 = Default 11 = Dither is disabled for channel A. In this mode, SNR typically improves by 0.2 dB at 70 MHz.
<b>Bits 2:0</b>	<b>Must write 0</b>

**Figure 48. Register 139h**

7	6	5	4	3	2	1	0
0	0	0	0	SP1 CHA	0	0	0

**Table 24. Register 139h Description**

Name	Description
<b>Bits 7:4</b>	<b>Must write 0</b>
<b>Bit D3</b>	<b>SP1 CHA: Special mode for best performance on channel A</b> Always write 1 after reset.
<b>Bits 2:0</b>	<b>Must write 0</b>

**Figure 49. Register 222h**

7	6	5	4	3	2	1	0
0	0	0	0	0	0	DIS CHOP CHD	0

**Table 25. Register 222h Description**

Name	Description
<b>Bits 7:2</b>	<b>Must write 0</b>
<b>Bit 1</b>	<b>DIS CHOP CHD: Disable chopper</b> Set this bit to shift 1/f noise floor at dc. 0 = 1/f noise floor is centered at $f_s / 2$ (default) 1 = Chopper mechanism is disabled; 1/f noise floor is centered at dc
<b>Bit 0</b>	<b>Must write 0</b>

**Figure 50. Register 234h**

7	6	5	4	3	2	1	0
0	0	DIS DITH CHD	0	DIS DITH CHD	0	0	0

**Table 26. Register 234h Description**

Name	Description
<b>Bits 7:6</b>	<b>Must write 0</b>
<b>Bit 5</b>	<b>DIS DITH CHD</b> Set this bit with bits 1 and 0 of register 01h. 00 = Default 11 = Dither is disabled for channel D. In this mode, SNR typically improves by 0.2 dB at 70 MHz.
<b>Bit 4</b>	<b>Must write 0</b>
<b>Bit 3</b>	<b>DIS DITH CHD</b> Set this bit with bits 1 and 0 of register 01h. 00 = Default 11 = Dither is disabled for channel D. In this mode, SNR typically improves by 0.2 dB at 70 MHz.
<b>Bits 2:0</b>	<b>Must write 0</b>

**Figure 51. Register 239h**

7	6	5	4	3	2	1	0
0	0	0	0	SP1 CHD	0	0	0

**Table 27. Register 239h Description**

Name	Description
Bits 7:4	<b>Must write 0</b>
Bit D3	<b>SP1 CHD: Special mode for best performance on channel D</b> Always write 1 after reset.
Bits 2:0	<b>Must write 0</b>

**Figure 52. Register 422h**

7	6	5	4	3	2	1	0
0	0	0	0	0	0	DIS CHOP CHB	0

**Table 28. Register 422h Description**

Name	Description
Bits 7:2	<b>Must write 0</b>
Bit 1	<b>DIS CHOP CHB: Disable chopper</b> Set this bit to shift 1/f noise floor at dc. 0 = 1/f noise floor is centered at $f_s / 2$ (default) 1 = Chopper mechanism is disabled; 1/f noise floor is centered at dc
Bit 0	<b>Must write 0</b>

**Figure 53. Register 434h**

7	6	5	4	3	2	1	0
0	0	DIS DITH CHB	0	DIS DITH CHB	0	0	0

**Table 29. Register 434h Description**

Name	Description
Bits 7:6	<b>Must write 0</b>
Bit 5	<b>DIS DITH CHB</b> Set this bit with bits 5 and 4 of register 01h. 00 = Default 11 = Dither is disabled for channel B. In this mode, SNR typically improves by 0.2 dB at 70 MHz.
Bit 4	<b>Must write 0</b>
Bit 3	<b>DIS DITH CHB</b> Set this bit with bits 5 and 4 of register 01h. 00 = Default 11 = Dither is disabled for channel B. In this mode, SNR typically improves by 0.2 dB at 70 MHz.
Bits 2:0	<b>Must write 0</b>

**Figure 54. Register 439h**

7	6	5	4	3	2	1	0
0	0	0	0	SP1 CHB	0	0	0

**Table 30. Register 439h Description**

Name	Description
<b>Bits 7:4</b>	<b>Must write 0</b>
<b>Bit D3</b>	<b>SP1 CHB: Special mode for best performance on channel B</b>
	Always write 1 after reset.
<b>Bits 2:0</b>	<b>Must write 0</b>

**Figure 55. Register 522h**

7	6	5	4	3	2	1	0
0	0	0	0	0	0	DIS CHOP CHC	0

**Table 31. Register 522h Description**

Name	Description
<b>Bits 7:2</b>	<b>Must write 0</b>
<b>Bit 1</b>	<b>DIS CHOP CHC: Disable chopper</b>
	Set this bit to shift 1/f noise floor at dc. 0 = 1/f noise floor is centered at $f_s / 2$ (default) 1 = Chopper mechanism is disabled; 1/f noise floor is centered at dc
<b>Bit 0</b>	<b>Must write 0</b>

**Figure 56. Register 534h**

7	6	5	4	3	2	1	0
0	0	DIS DITH CHC	0	DIS DITH CHC	0	0	0

**Table 32. Register 534h Description**

Name	Description
<b>Bits 7:6</b>	<b>Must write 0</b>
<b>Bit 5</b>	<b>DIS DITH CHC</b>
	Set this bit with bits 3 and 2 of register 01h. 00 = Default 11 = Dither is disabled for channel C. In this mode, SNR typically improves by 0.2 dB at 70 MHz.
<b>Bit 4</b>	<b>Must write 0</b>
<b>Bit 3</b>	<b>DIS DITH CHC</b>
	Set this bit with bits 3 and 2 of register 01h. 00 = Default 11 = Dither is disabled for channel C. In this mode, SNR typically improves by 0.2 dB at 70 MHz.
<b>Bits 2:0</b>	<b>Must write 0</b>

**Figure 57. Register 539h**

7	6	5	4	3	2	1	0
0	0	0	0	SP1 CHC	0	0	0

**Table 33. Register 539h Description**

Name	Description
<b>Bits 7:4</b>	<b>Must write 0</b>
<b>Bit D3</b>	<b>SP1 CHC: Special mode for best performance on channel C</b>
	Always write 1 after reset.
<b>Bits 2:0</b>	<b>Must write 0</b>

## 10 Applications and Implementation

### 10.1 Application Information

Typical applications involving transformer-coupled circuits are discussed in this section. Transformers (such as ADT1-1WT or WBC1-1) can be used up to 250 MHz to achieve good phase and amplitude balances at ADC inputs. While designing the dc driving circuits, the ADC input impedance must be considered. Figure 58 and Figure 59 show the impedance ( $Z_{in} = R_{in} \parallel C_{in}$ ) across the ADC input pins.

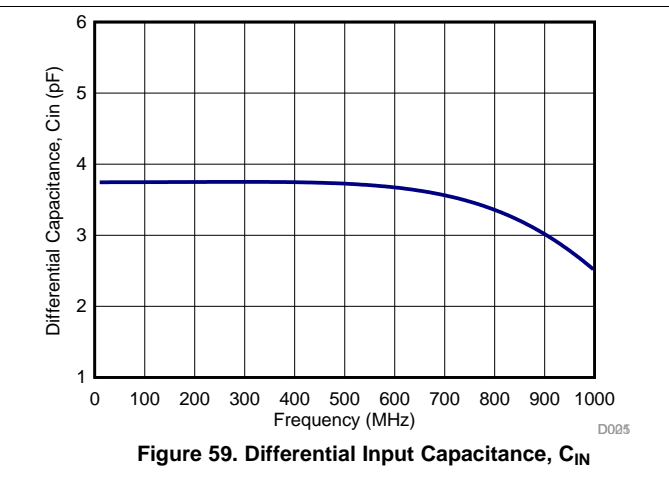
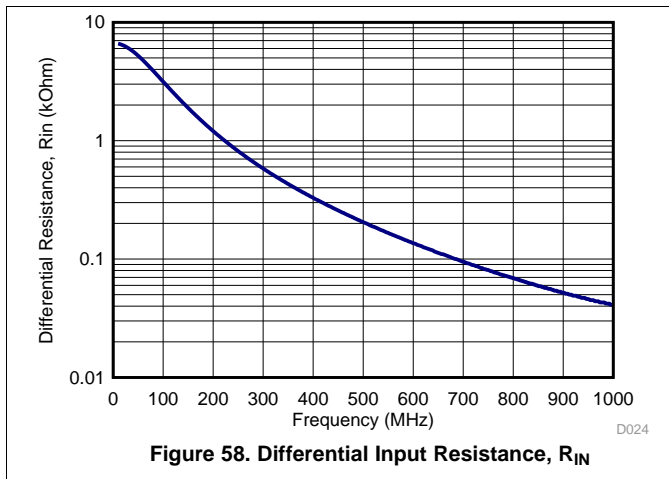

### 10.2 Typical Applications

#### 10.2.1 Driving Circuit Design: Low Input Frequencies

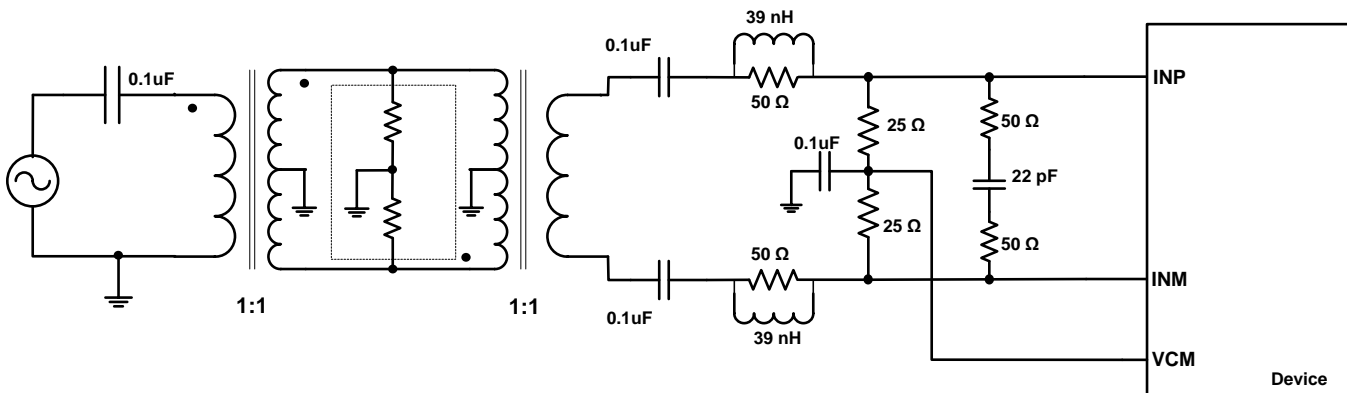

Figure 60. Driving Circuit for Low Input Frequencies

##### 10.2.1.1 Design Requirements

For optimum performance, the analog inputs must be driven differentially. An optional 5-Ω to 15-Ω resistor in series with each input pin can be kept to damp out ringing caused by package parasitic. The drive circuit may have to be designed to minimize the impact of kick-back noise generated by sampling switches opening and closing inside the ADC, as well as ensuring low insertion loss over the desired frequency range and matched impedance to the source.

##### 10.2.1.2 Detailed Design Procedure

A typical application involving using two back-to-back coupled transformers is illustrated in Figure 60. The circuit is optimized for low input frequencies. An external R-C-R filter using 50-Ω resistors and a 22-pF capacitor is used with the series inductor (39 nH), this combination helps absorb the sampling glitches.

**Typical Applications (continued)**

**10.2.1.3 Application Curve**

Figure 61 shows the performance obtained by using the circuit shown in Figure 60.

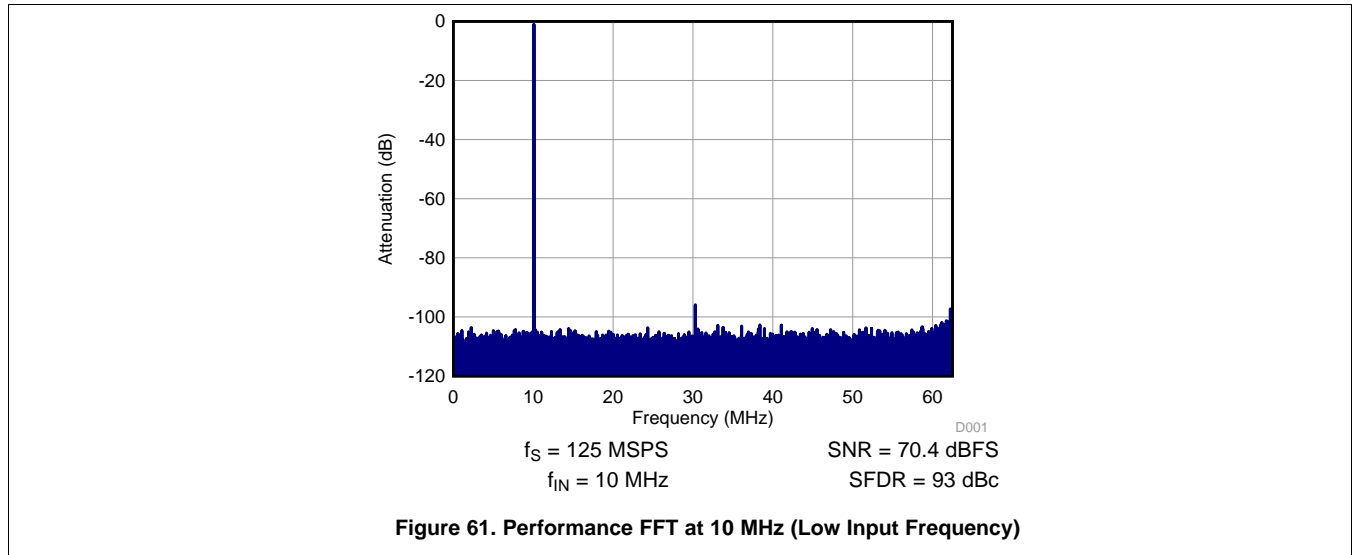

**PRODUCT PREVIEW**

Typical Applications (continued)

10.2.2 Driving Circuit Design: Input Frequencies Between 100 MHz to 230 MHz

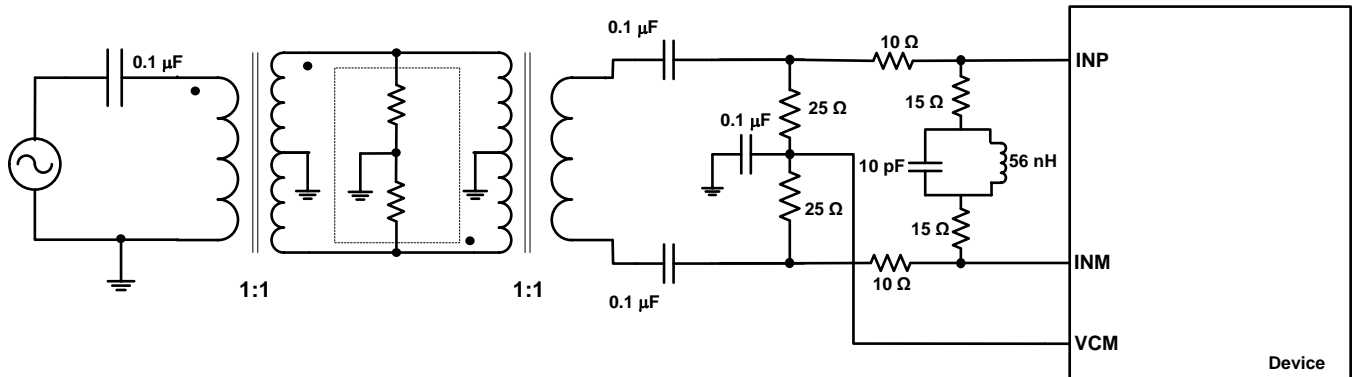

Figure 62. Driving Circuit for Mid-Range Input Frequencies ( $100 \text{ MHz} < f_{IN} < 230 \text{ MHz}$ )

10.2.2.1 Design Requirements

See the [Design Requirements](#) section for further details.

10.2.2.2 Detailed Design Procedure

When input frequencies are between 100 MHz to 230 MHz, an R-LC-R circuit can be used to optimize performance, as shown in [Figure 62](#).

10.2.2.3 Application Curve

[Figure 63](#) shows the performance obtained by using the circuit shown in [Figure 62](#).

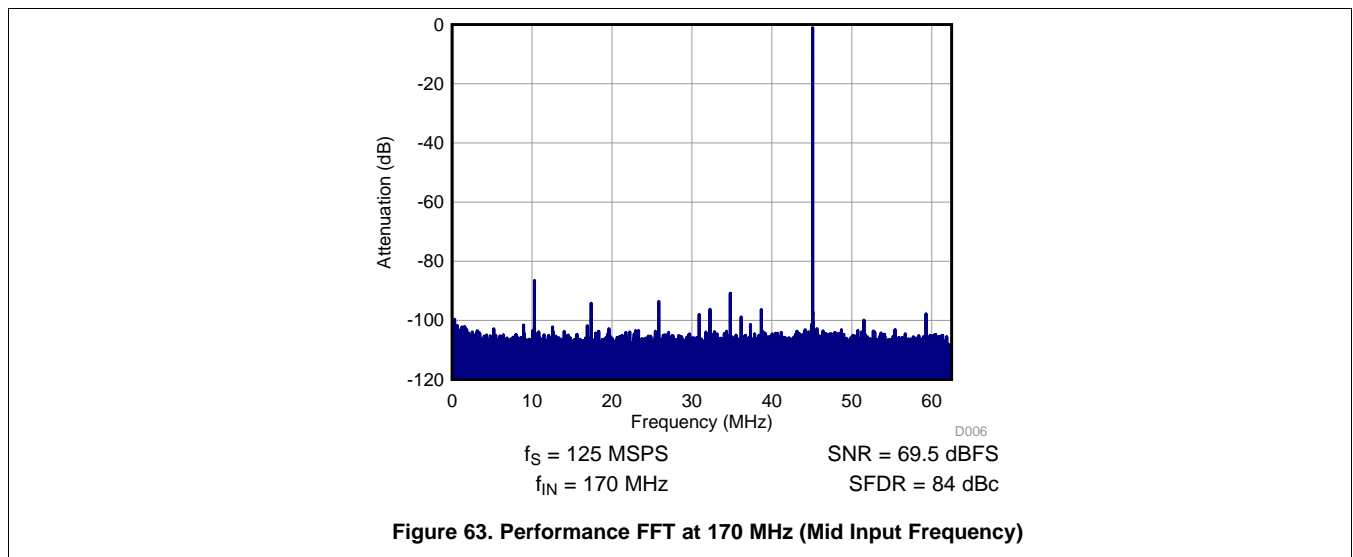

Figure 63. Performance FFT at 170 MHz (Mid Input Frequency)

Typical Applications (continued)

10.2.3 Driving Circuit Design: Input Frequencies Greater than 230 MHz

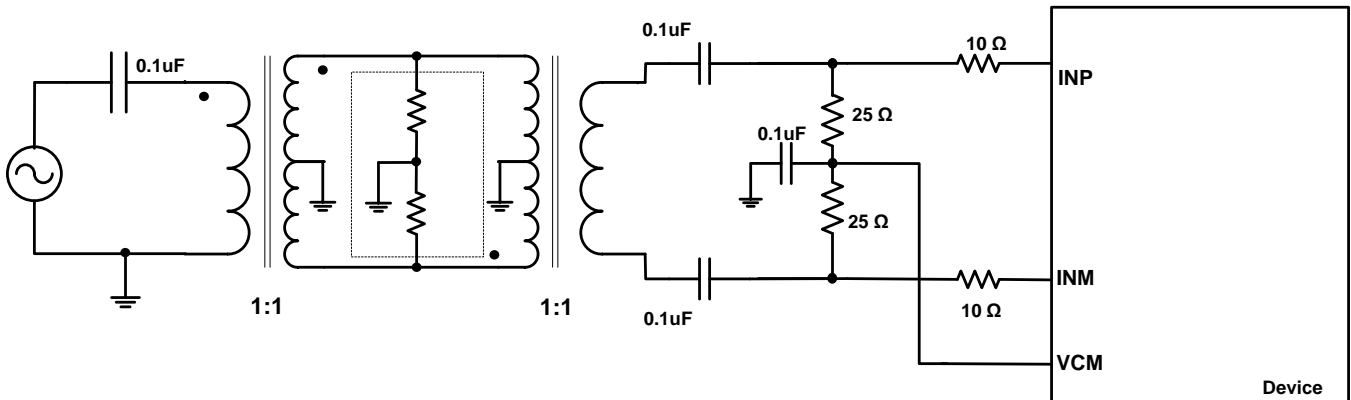

Figure 64. Driving Circuit for High Input Frequencies ( $f_{IN} > 230$  MHz)

10.2.3.1 Design Requirements

See the [Design Requirements](#) section for further details.

10.2.3.2 Detailed Design Procedure

For high input frequencies ( $> 230$  MHz), using the R-C-R or R-LC-R circuit does not show significant improvement in performance. However, a series resistance of  $10 \Omega$  can be used as shown in [Figure 64](#).

10.2.3.3 Application Curve

[Figure 65](#) shows the performance obtained by using the circuit shown in [Figure 64](#).

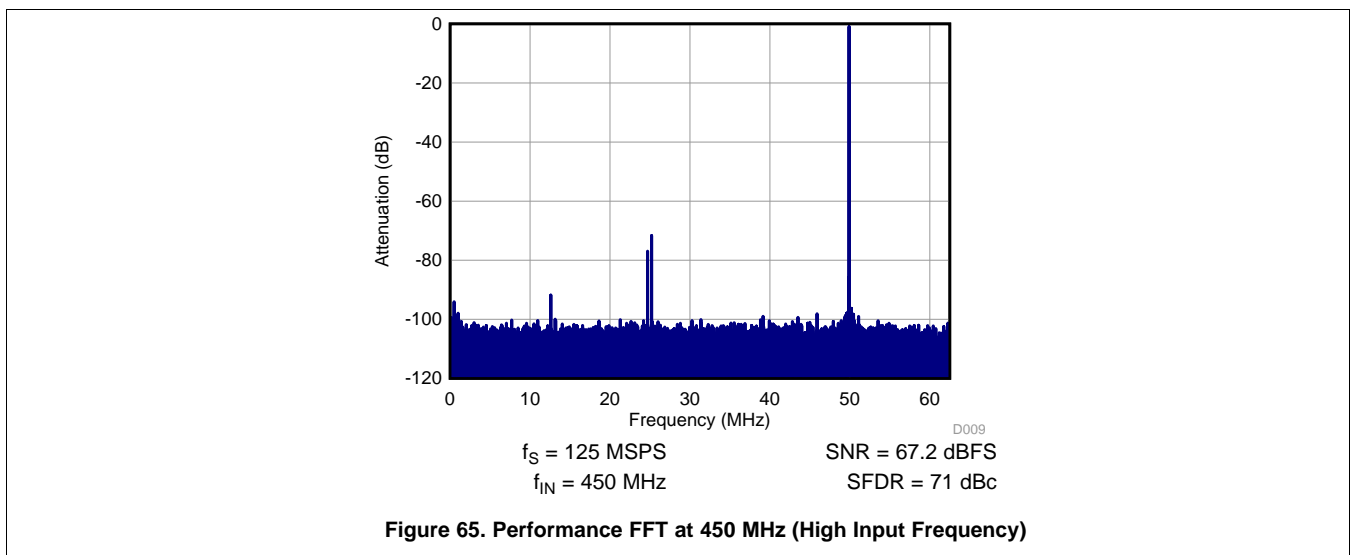

Figure 65. Performance FFT at 450 MHz (High Input Frequency)

11 Power Supply Recommendations

The device requires a 1.8-V nominal supply for AVDD and DVDD. There are no specific sequence power-supply requirements during device power-up. AVDD and DVDD can power up in any order.

## 12 Layout

### 12.1 Layout Guidelines

The ADC342x EVM layout can be used as a reference layout to obtain the best performance. A layout diagram of the EVM top layer is provided in [Figure 66](#). Some important points to remember during laying out the board are:

1. Analog inputs are located on opposite sides of the device pin out to ensure minimum crosstalk on the package level. To minimize crosstalk onboard, the analog inputs should exit the pin out in opposite directions, as shown in the reference layout of [Figure 66](#) as much as possible.
2. In the device pin out, the sampling clock is located on a side perpendicular to the analog inputs in order to minimize coupling between them. This configuration is also maintained on the reference layout of [Figure 66](#) as much as possible.
3. Digital outputs should be kept away from the analog inputs. When these digital outputs exit the pin out, the digital output traces should not be kept parallel to the analog input traces because this configuration may result in coupling from digital outputs to analog inputs and degrade performance. All digital output traces to the receiver [such as a field-programmable gate array (FPGA) or an application-specific integrated circuit (ASIC)] should be matched in length to avoid skew among outputs.
4. At each power-supply pin (AVDD and DVDD), a 0.1- $\mu\text{F}$  decoupling capacitor should be kept close to the device. A separate decoupling capacitor group consisting of a parallel combination of 10- $\mu\text{F}$ , 1- $\mu\text{F}$ , and 0.1- $\mu\text{F}$  capacitors can be kept close to the supply source.

### 12.2 Layout Example

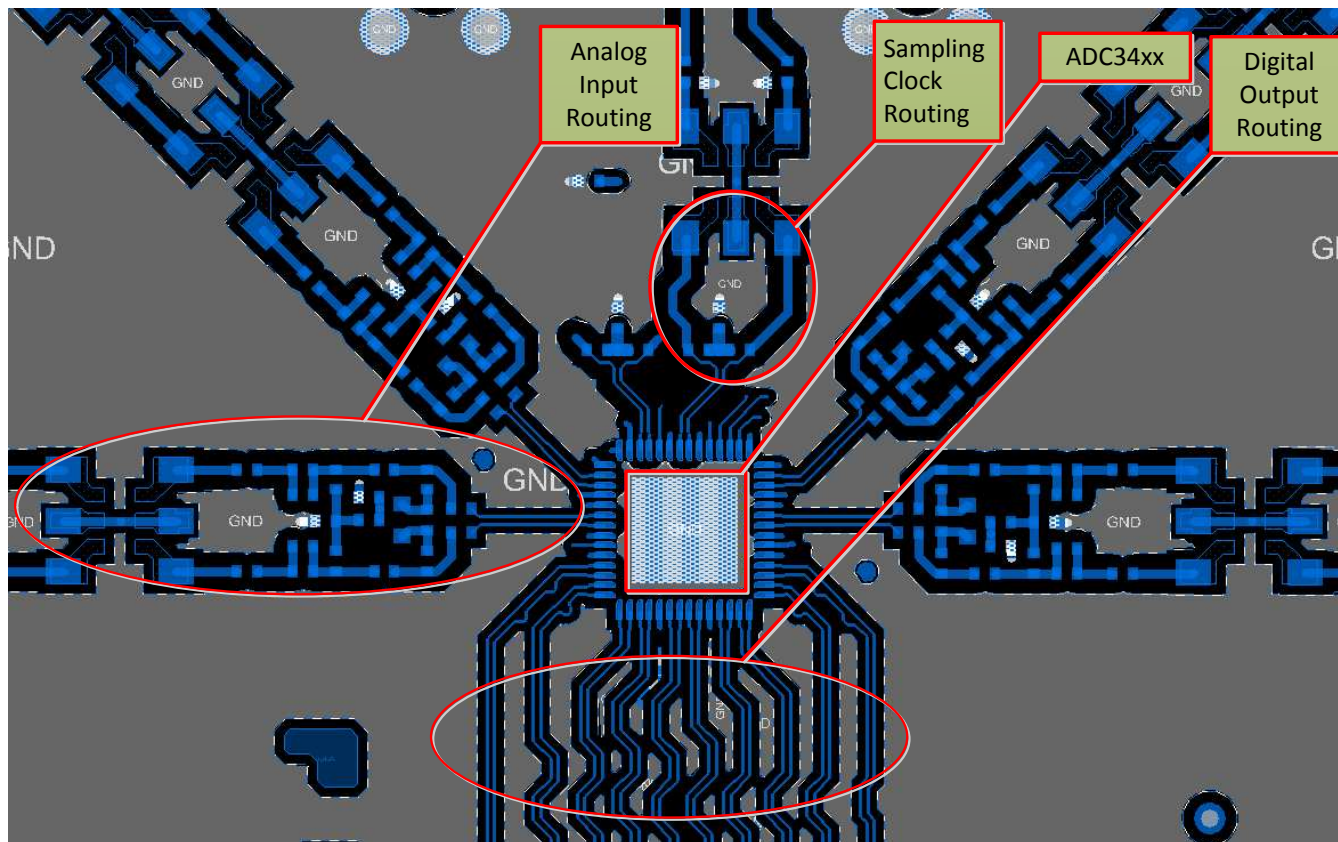

**Figure 66. Typical Layout of the ADC342x Board**

## 13 Device and Documentation Support

### 13.1 Related Links

The table below lists quick access links. Categories include technical documents, support and community resources, tools and software, and quick access to sample or buy.

**Table 34. Related Links**

PARTS	PRODUCT FOLDER	SAMPLE & BUY	TECHNICAL DOCUMENTS	TOOLS & SOFTWARE	SUPPORT & COMMUNITY
ADC3421	<a href="#">Click here</a>	<a href="#">Click here</a>	<a href="#">Click here</a>	<a href="#">Click here</a>	<a href="#">Click here</a>
ADC3422	<a href="#">Click here</a>	<a href="#">Click here</a>	<a href="#">Click here</a>	<a href="#">Click here</a>	<a href="#">Click here</a>
ADC3423	<a href="#">Click here</a>	<a href="#">Click here</a>	<a href="#">Click here</a>	<a href="#">Click here</a>	<a href="#">Click here</a>
ADC3424	<a href="#">Click here</a>	<a href="#">Click here</a>	<a href="#">Click here</a>	<a href="#">Click here</a>	<a href="#">Click here</a>

### 13.2 Trademarks

PowerPAD is a trademark of Texas Instruments, Inc.  
All other trademarks are the property of their respective owners.

### 13.3 Electrostatic Discharge Caution



This integrated circuit can be damaged by ESD. Texas Instruments recommends that all integrated circuits be handled with appropriate precautions. Failure to observe proper handling and installation procedures can cause damage.

ESD damage can range from subtle performance degradation to complete device failure. Precision integrated circuits may be more susceptible to damage because very small parametric changes could cause the device not to meet its published specifications.

### 13.4 Glossary

[SLYZ022](#) — *TI Glossary*.

This glossary lists and explains terms, acronyms, and definitions.

## 14 Mechanical, Packaging, and Orderable Information

The following pages include mechanical, packaging, and orderable information. This information is the most current data available for the designated devices. This data is subject to change without notice and revision of this document. For browser-based versions of this data sheet, refer to the left-hand navigation.

**PACKAGING INFORMATION**

Orderable Device	Status (1)	Package Type	Package Drawing	Pins	Package Qty	Eco Plan (2)	Lead/Ball Finish (6)	MSL Peak Temp (3)	Op Temp (°C)	Device Marking (4/5)	Samples
ADC3421IRTQR	PREVIEW	QFN	RTQ	56	2000	TBD	Call TI	Call TI	-40 to 85		
ADC3421IRTQT	PREVIEW	QFN	RTQ	56	250	TBD	Call TI	Call TI	-40 to 85		
ADC3422IRTQR	PREVIEW	QFN	RTQ	56	2000	TBD	Call TI	Call TI	-40 to 85		
ADC3422IRTQT	PREVIEW	QFN	RTQ	56	250	TBD	Call TI	Call TI	-40 to 85		
ADC3423IRTQR	PREVIEW	QFN	RTQ	56	2000	TBD	Call TI	Call TI	-40 to 85		
ADC3423IRTQT	PREVIEW	QFN	RTQ	56	250	TBD	Call TI	Call TI	-40 to 85		
ADC3424IRTQR	PREVIEW	QFN	RTQ	56	2000	TBD	Call TI	Call TI	-40 to 85		
ADC3424IRTQT	PREVIEW	QFN	RTQ	56	250	TBD	Call TI	Call TI	-40 to 85		

(1) The marketing status values are defined as follows:

**ACTIVE:** Product device recommended for new designs.

**LIFEBUY:** TI has announced that the device will be discontinued, and a lifetime-buy period is in effect.

**NRND:** Not recommended for new designs. Device is in production to support existing customers, but TI does not recommend using this part in a new design.

**PREVIEW:** Device has been announced but is not in production. Samples may or may not be available.

**OBSELETE:** TI has discontinued the production of the device.

(2) Eco Plan - The planned eco-friendly classification: Pb-Free (RoHS), Pb-Free (RoHS Exempt), or Green (RoHS & no Sb/Br) - please check <http://www.ti.com/productcontent> for the latest availability information and additional product content details.

**TBD:** The Pb-Free/Green conversion plan has not been defined.

**Pb-Free (RoHS):** TI's terms "Lead-Free" or "Pb-Free" mean semiconductor products that are compatible with the current RoHS requirements for all 6 substances, including the requirement that lead not exceed 0.1% by weight in homogeneous materials. Where designed to be soldered at high temperatures, TI Pb-Free products are suitable for use in specified lead-free processes.

**Pb-Free (RoHS Exempt):** This component has a RoHS exemption for either 1) lead-based flip-chip solder bumps used between the die and package, or 2) lead-based die adhesive used between the die and leadframe. The component is otherwise considered Pb-Free (RoHS compatible) as defined above.

**Green (RoHS & no Sb/Br):** TI defines "Green" to mean Pb-Free (RoHS compatible), and free of Bromine (Br) and Antimony (Sb) based flame retardants (Br or Sb do not exceed 0.1% by weight in homogeneous material)

(3) MSL, Peak Temp. - The Moisture Sensitivity Level rating according to the JEDEC industry standard classifications, and peak solder temperature.

(4) There may be additional marking, which relates to the logo, the lot trace code information, or the environmental category on the device.

(5) Multiple Device Markings will be inside parentheses. Only one Device Marking contained in parentheses and separated by a "~" will appear on a device. If a line is indented then it is a continuation of the previous line and the two combined represent the entire Device Marking for that device.

(6) Lead/Ball Finish - Orderable Devices may have multiple material finish options. Finish options are separated by a vertical ruled line. Lead/Ball Finish values may wrap to two lines if the finish value exceeds the maximum column width.

**Important Information and Disclaimer:** The information provided on this page represents TI's knowledge and belief as of the date that it is provided. TI bases its knowledge and belief on information provided by third parties, and makes no representation or warranty as to the accuracy of such information. Efforts are underway to better integrate information from third parties. TI has taken and continues to take reasonable steps to provide representative and accurate information but may not have conducted destructive testing or chemical analysis on incoming materials and chemicals. TI and TI suppliers consider certain information to be proprietary, and thus CAS numbers and other limited information may not be available for release.

In no event shall TI's liability arising out of such information exceed the total purchase price of the TI part(s) at issue in this document sold by TI to Customer on an annual basis.

RTQ (S-PVQFN-N56)

PLASTIC QUAD FLATPACK NO-LEAD

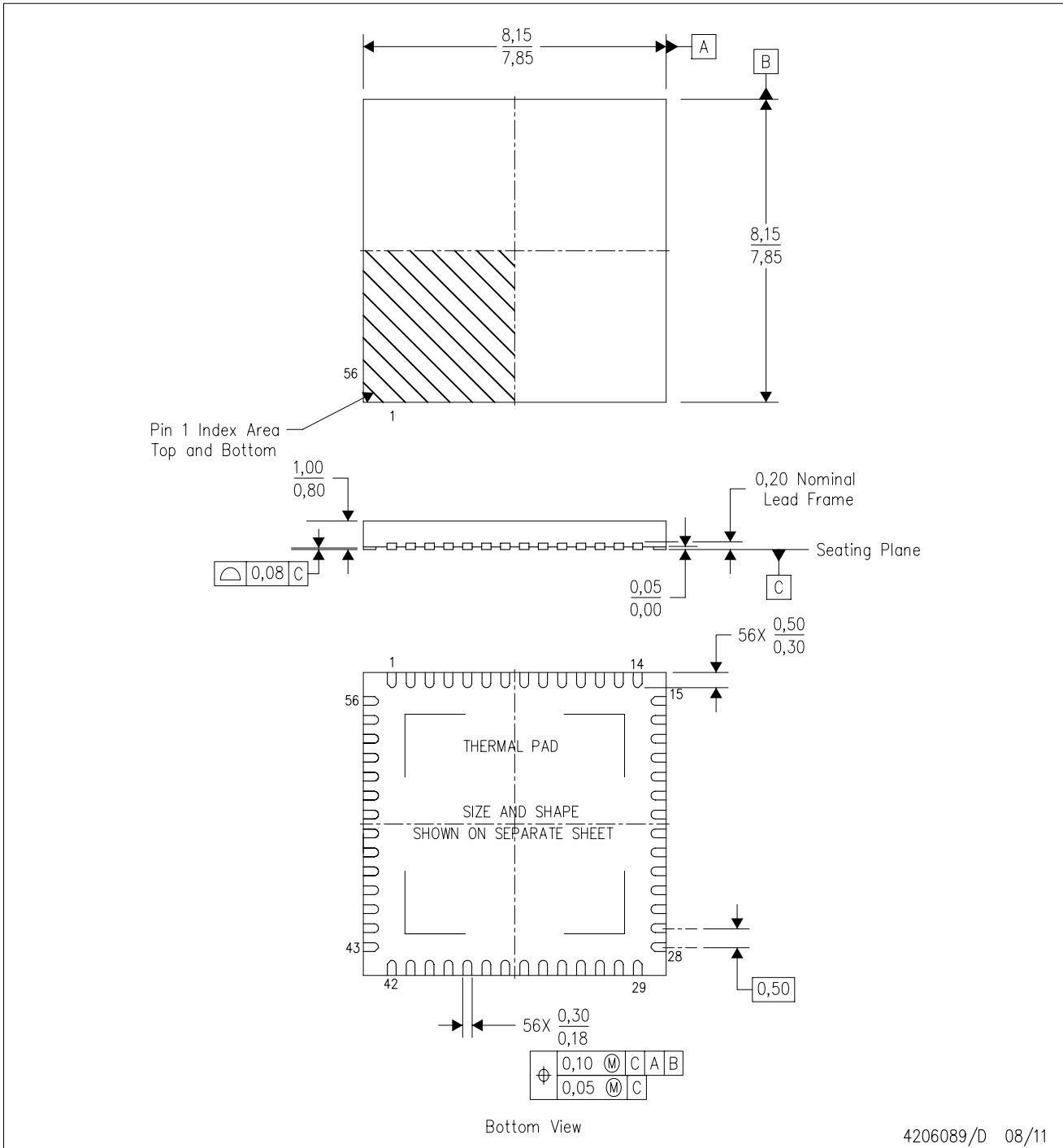

- NOTES:
- All linear dimensions are in millimeters. Dimensioning and tolerancing per ASME Y14.5-1994.
  - This drawing is subject to change without notice.
  - QFN (Quad Flatpack No-Lead) Package configuration.
  - The package thermal pad must be soldered to the board for thermal and mechanical performance.
  - See the additional figure in the Product Data Sheet for details regarding the exposed thermal pad features and dimensions.
  - Package complies to JEDEC MO-220.

## IMPORTANT NOTICE

Texas Instruments Incorporated and its subsidiaries (TI) reserve the right to make corrections, enhancements, improvements and other changes to its semiconductor products and services per JESD46, latest issue, and to discontinue any product or service per JESD48, latest issue. Buyers should obtain the latest relevant information before placing orders and should verify that such information is current and complete. All semiconductor products (also referred to herein as "components") are sold subject to TI's terms and conditions of sale supplied at the time of order acknowledgment.

TI warrants performance of its components to the specifications applicable at the time of sale, in accordance with the warranty in TI's terms and conditions of sale of semiconductor products. Testing and other quality control techniques are used to the extent TI deems necessary to support this warranty. Except where mandated by applicable law, testing of all parameters of each component is not necessarily performed.

TI assumes no liability for applications assistance or the design of Buyers' products. Buyers are responsible for their products and applications using TI components. To minimize the risks associated with Buyers' products and applications, Buyers should provide adequate design and operating safeguards.

TI does not warrant or represent that any license, either express or implied, is granted under any patent right, copyright, mask work right, or other intellectual property right relating to any combination, machine, or process in which TI components or services are used. Information published by TI regarding third-party products or services does not constitute a license to use such products or services or a warranty or endorsement thereof. Use of such information may require a license from a third party under the patents or other intellectual property of the third party, or a license from TI under the patents or other intellectual property of TI.

Reproduction of significant portions of TI information in TI data books or data sheets is permissible only if reproduction is without alteration and is accompanied by all associated warranties, conditions, limitations, and notices. TI is not responsible or liable for such altered documentation. Information of third parties may be subject to additional restrictions.

Resale of TI components or services with statements different from or beyond the parameters stated by TI for that component or service voids all express and any implied warranties for the associated TI component or service and is an unfair and deceptive business practice. TI is not responsible or liable for any such statements.

Buyer acknowledges and agrees that it is solely responsible for compliance with all legal, regulatory and safety-related requirements concerning its products, and any use of TI components in its applications, notwithstanding any applications-related information or support that may be provided by TI. Buyer represents and agrees that it has all the necessary expertise to create and implement safeguards which anticipate dangerous consequences of failures, monitor failures and their consequences, lessen the likelihood of failures that might cause harm and take appropriate remedial actions. Buyer will fully indemnify TI and its representatives against any damages arising out of the use of any TI components in safety-critical applications.

In some cases, TI components may be promoted specifically to facilitate safety-related applications. With such components, TI's goal is to help enable customers to design and create their own end-product solutions that meet applicable functional safety standards and requirements. Nonetheless, such components are subject to these terms.

No TI components are authorized for use in FDA Class III (or similar life-critical medical equipment) unless authorized officers of the parties have executed a special agreement specifically governing such use.

Only those TI components which TI has specifically designated as military grade or "enhanced plastic" are designed and intended for use in military/aerospace applications or environments. Buyer acknowledges and agrees that any military or aerospace use of TI components which have **not** been so designated is solely at the Buyer's risk, and that Buyer is solely responsible for compliance with all legal and regulatory requirements in connection with such use.

TI has specifically designated certain components as meeting ISO/TS16949 requirements, mainly for automotive use. In any case of use of non-designated products, TI will not be responsible for any failure to meet ISO/TS16949.

### Products

Audio	<a href="http://www.ti.com/audio">www.ti.com/audio</a>
Amplifiers	<a href="http://amplifier.ti.com">amplifier.ti.com</a>
Data Converters	<a href="http://dataconverter.ti.com">dataconverter.ti.com</a>
DLP® Products	<a href="http://www.dlp.com">www.dlp.com</a>
DSP	<a href="http://dsp.ti.com">dsp.ti.com</a>
Clocks and Timers	<a href="http://www.ti.com/clocks">www.ti.com/clocks</a>
Interface	<a href="http://interface.ti.com">interface.ti.com</a>
Logic	<a href="http://logic.ti.com">logic.ti.com</a>
Power Mgmt	<a href="http://power.ti.com">power.ti.com</a>
Microcontrollers	<a href="http://microcontroller.ti.com">microcontroller.ti.com</a>
RFID	<a href="http://www.ti-rfid.com">www.ti-rfid.com</a>
OMAP Applications Processors	<a href="http://www.ti.com/omap">www.ti.com/omap</a>
Wireless Connectivity	<a href="http://www.ti.com/wirelessconnectivity">www.ti.com/wirelessconnectivity</a>

### Applications

Automotive and Transportation	<a href="http://www.ti.com/automotive">www.ti.com/automotive</a>
Communications and Telecom	<a href="http://www.ti.com/communications">www.ti.com/communications</a>
Computers and Peripherals	<a href="http://www.ti.com/computers">www.ti.com/computers</a>
Consumer Electronics	<a href="http://www.ti.com/consumer-apps">www.ti.com/consumer-apps</a>
Energy and Lighting	<a href="http://www.ti.com/energy">www.ti.com/energy</a>
Industrial	<a href="http://www.ti.com/industrial">www.ti.com/industrial</a>
Medical	<a href="http://www.ti.com/medical">www.ti.com/medical</a>
Security	<a href="http://www.ti.com/security">www.ti.com/security</a>
Space, Avionics and Defense	<a href="http://www.ti.com/space-avionics-defense">www.ti.com/space-avionics-defense</a>
Video and Imaging	<a href="http://www.ti.com/video">www.ti.com/video</a>

### TI E2E Community

[e2e.ti.com](http://e2e.ti.com)